

# AD-100

## Installation Manual

**WARNING:** For your safety the information in this manual must be followed to minimize the risk of fire or explosion or to prevent property damage, personal injury or loss of life.

Do not store or use gasoline or other flammable vapors and liquids in the vicinity of this or any other appliance.

### WHAT TO DO IF YOU SMELL GAS

- Do not try to light any appliance.
- Do not touch any electrical switch; do not use any phone in your building.
- Clear the room, building or area of all occupants.
- Immediately call your gas supplier from a neighbor's phone. Follow the gas supplier's instructions.
- If you cannot reach your gas supplier, call the fire department.

Installation and service must be performed by a qualified installer, service agency or the gas supplier.



For replacement parts, contact the distributor from which the dryer was purchased or

**American Dryer Corporation**

88 Currant Road Fall River, MA 02720-4781

Telephone: (508) 678-9010 / Cable: AMDRY

Telex: 927520 AMDRY FRIV / Fax: (508) 678-9447

ADC Part No. 112125

## **Retain This Manual In A Safe Place For Future Reference**

American Dryer Corporation products embody advanced concepts in engineering, design, and safety. If this product is properly maintained, it will provide many years of safe, efficient, and trouble-free operation.

**ONLY** properly licensed technicians should service this equipment.

Observe all safety precautions displayed on the equipment or specified in the installation/operator's manual included with the dryer.

Under **NO circumstances should the dryer door switch or the heat circuit devices ever be disabled.**

We have tried to make this manual as complete as possible and hope you will find it useful. ADC reserves the right to make changes from time to time, without notice or obligation, in prices, specifications, colors, and materials and to change or discontinue models.

### **Important**

For your convenience, log the following information:

DATE OF PURCHASE \_\_\_\_\_ MODEL NO. **AD-100** \_\_\_\_\_

DISTRIBUTOR'S NAME \_\_\_\_\_

Serial No.(s) \_\_\_\_\_

Replacement parts can be ordered from your distributor or the ADC factory. When ordering replacement parts from the factory, you can fax your order to ADC at (508) 678-9447 or telephone your orders directly to the ADC Parts Department at (508) 678-9010. Please specify the dryer model number and serial number in addition to the description and part number, so that your order is processed accurately and promptly.

The illustrations on the following pages may not depict your particular dryer exactly. The illustrations are a composite of the various dryer models. Be sure to check the descriptions of the parts thoroughly before ordering.

**INSTRUCTIONS TO BE FOLLOWED IN THE EVENT THE USER SMELLS GAS MUST BE POSTED IN A PROMINENT LOCATION. THE INSTRUCTIONS TO BE POSTED SHALL BE OBTAINED FROM THE LOCAL GAS SUPPLIER.**

**FOR YOUR SAFETY**

DO NOT STORE OR USE GASOLINE OR OTHER FLAMMABLE VAPORS AND LIQUIDS IN THE VICINITY OF THIS OR ANY OTHER APPLIANCE.

DO NOT DRY MOP HEADS IN THE DRYER.

DO NOT USE DRYER IN THE PRESENCE OF DRY CLEANING FUMES.

**WARNING**

CHILDREN SHOULD NOT BE ALLOWED TO PLAY ON OR IN THE DRYER(S).

CHILDREN SHOULD BE SUPERVISED IF NEAR DRYER(S) IN OPERATION.

**CAUTION**

DRYER(S) SHOULD NEVER BE LEFT UNATTENDED WHILE IN OPERATION.

**IMPORTANT**

Please observe all safety precautions displayed on the equipment and/or specified in the installation/operators manual included with the dryer.

Dryer(s) must not be installed or stored in an area where it will be exposed to water and/or weather.

The wiring diagram for the dryer is located in the front electrical control box area.

# Table of Contents

<b>SECTION I</b>	
<b>IMPORTANT INFORMATION</b>	<b>2</b>
A. Receiving and Handling	2
B. Safety Precautions	3
<b>SECTION II</b>	
<b>SPECIFICATIONS / COMPONENT IDENTIFICATION</b>	<b>5</b>
A. Specifications (Gas and Steam Models)	5
B. Component Identification	6
<b>SECTION III</b>	
<b>INSTALLATION PROCEDURES</b>	<b>8</b>
A. Location Requirements	8
B. Unpacking / Setting Up	9
C. Dryer Enclosure Requirements	11
D. Fresh Air Supply	12
E. Exhaust Requirements	13
F. Electrical Information	19
G. Gas Information	23
H. Steam Information	27
I. Preparation For Operation / Start-Up	31
J. Preoperational Tests	32

**SECTION IV  
SERVICE / PARTS INFORMATION ..... 35**

A. Service ..... 35

B. Parts ..... 35

**SECTION V  
WARRANTY INFORMATION ..... 36**

A. Returning Warranty Card(s) ..... 36

B. Warranty ..... 36

C. Returning Warranty Part(s) ..... 36

**SECTION VI  
ROUTINE MAINTENANCE ..... 38**

A. Cleaning ..... 38

B. Adjustments ..... 39

**SECTION VII  
TROUBLESHOOTING ..... 40**

# SECTION I

## IMPORTANT INFORMATION

### A. RECEIVING and HANDLING

The dryer is shipped in a protective stretch wrap cover with protective cardboard corners and top cover (or optional box) as a means of preventing damage in transit. Upon delivery, the dryer and/or protective packaging, and wooden skid **should be** visually inspected for shipping damage. If any damage whatsoever is noticed, inspect further before delivering carrier leaves.

Dryers damaged in shipment:

1. All dryers **should be** inspected upon receipt and before they are signed for.
2. If there is suspected damage or actual damage, the trucker's receipt **should be** so noted.
3. If the dryer is damaged beyond repair, it **should be** refused. Those dryers which were not damaged in a damaged shipment **should be** accepted, but the number received and number refused **must be** noted on the receipt.
4. If you determine that the dryer was damaged after the trucker has left your location, you should call the delivering carrier's freight terminal immediately and file a claim. The freight company considers this concealed damage. This type of freight claim is very difficult to get paid and becomes extremely difficult when more than a day or two passes after the freight was delivered. It is your responsibility to file freight claims. Dryers/parts damaged in transit **cannot** be claimed under warranty.
5. Freight claims are the responsibility of the consignee, and all claims **must be** filed at the receiving end. ADC assumes no responsibility for freight claims or damages.
6. If you need assistance in handling the situation, please contact the ADC traffic manager at (508) 678-9000.

**IMPORTANT:** The dryer **must be** transported and handled in an upright position at all times.

## B. SAFETY PRECAUTIONS

**WARNING:** For your safety, the information in this manual **must be followed** to minimize the risk of fire or explosion or to prevent property damage, personal injury or loss of life.

1. **Do not** store or use gasoline or other flammable vapors and liquids in the vicinity of this or any other appliance.
2. Purchaser/user should consult the local gas supplier for proper instructions to be followed in the event the user smells gas. The instructions **should be** posted in a prominent location.
3. WHAT TO DO IF YOU SMELL GAS...
  - A) **Do not** try to light any appliance.
  - B) **Do not** touch any electrical switch.
  - C) **Do not** use any phone in your building.
  - D) Clear the room, building or area of all occupants.
  - E) Immediately call your gas supplier from a neighbor's phone. Follow the gas supplier's instructions.
  - F) If you **cannot** reach your gas supplier, call the fire department.
4. Installation and service **must be** performed by a qualified installer, service agency, or the gas supplier.
5. Dryer(s) **must be** exhausted to the outdoors.
6. Although ADC produces a very versatile machine, there are some articles that, due to fabric composition or cleaning method, **should not** be dried in it.

**WARNING:** Dry only water-washed fabrics. **Do not** dry articles spotted or washed in dry cleaning solvents, a combustible detergent, or "all purpose" cleaner. **EXPLOSION COULD RESULT.**

**WARNING:** **Do not** dry rags or articles coated or contaminated with gasoline, kerosene, oil, paint, or wax. **EXPLOSION COULD RESULT.**

**WARNING:** **Do not** dry mop heads. Contamination by wax or flammable solvents will create a fire hazard.

**WARNING:** Do not use heat for drying articles that contain plastic, foam, sponge rubber, or similarly textured rubber-like materials. Drying in a heated basket (tumbler) may damage plastics or rubber and also may be a fire hazard.

7. A program **should be** established for the inspection and cleaning of the lint in the burner area, exhaust duct work and area around the back of the dryer. The frequency of inspection and cleaning can best be determined from experience at each location.

**WARNING:** The collection of lint in the burner area and exhaust duct work can create a potential fire hazard.

8. For personal safety, the dryer must be electrically grounded in accordance with local codes and/or the NATIONAL ELECTRIC CODE ANSI/NFPA NO. 70-LATEST EDITION.

**NOTE:** Failure to do so will VOID THE WARRANTY.

9. **Under no circumstances** should the dryer door switch, lint drawer switch or heat circuit safety devices ever be disabled.

**WARNING: PERSONAL INJURY OR FIRE COULD RESULT.**

10. This dryer is not to be used in the presence of dry cleaning solvents or fumes.
11. Remove articles from the dryer as soon as the drying cycle has been completed.

**WARNING:** Articles left in the dryer after the drying and cooling cycles have been completed can create a fire hazard.

12. **Do not** operate steam dryers with more than 125 PSI steam pressure. Excessive steam pressure can damage steam coil and/or harm personnel.
13. Replace leaking flexible steam hoses or other steam fixtures immediately. **Do not** operate dryer with leaking flexible hoses. Personal injury may result.
14. **READ and FOLLOW ALL CAUTION and DIRECTION LABELS ATTACHED TO THE DRYER.**



# SECTION II

## SPECIFICATIONS / COMPONENT IDENTIFICATION

### A. SPECIFICATIONS

MAXIMUM CAPACITY (Dry Weight)		100 lbs.	45.4 kg
BASKET (Tumbler) DIAMETER		42"	106.7 cm
BASKET (Tumbler) DEPTH		42"	106.7 cm
MOTOR SIZE (Blower)		1 HP	.746 kw
MOTOR SIZE (Basket/Tumbler)		3/4 HP	.560 kw
MOTOR SIZE (Super Steam Blower)		3 HP	2.24 kw
DOOR OPENING (Diameter)		31-3/8"	79.7 cm
DRYERS PER 20' / 40' CONTAINER		4/8	
DRYERS PER 45' / 48' TRUCK		9/10	
APPROX. SHIPPING WEIGHT (Uncrated)		1300 lbs.	590 kg
APPROX. SHIPPING WEIGHT		1480 lbs.	671 kg
APPROX. SHIPPING WEIGHT (Uncrated) HT. REC.		1370 lbs.	620 kg
APPROX. SHIPPING WEIGHT - HT. REC.		1550 lbs.	700 kg
<b>GAS</b>	VOLTAGE AVAILABLE*	208-600v/3ø/3, 4w 50/60 Hz	
	AIR FLOW	1,700 cfm	48.1 cmm
	HEAT INPUT	265,000 btu/hr	67,000 kcal/hr
	GAS INLET	3/4"	1.90 cm
<b>GAS with Heat Reclaimer</b>	VOLTAGE AVAILABLE*	208-600v/3ø/3, 4w 50/60 Hz	
	AIR FLOW	1,060 cfm	30 cmm
	HEAT INPUT	250,000 btu/hr	63,000 kcal/hr
	GAS INLET	3/4"	1.90 cm

\* Refer to the **Electrical Service Specification** chart on **page 24** for detailed electrical information.

*Shaded areas are in metric equivalents.*

**NOTE:** ADC reserves the right to make changes in specifications at any time, without notice or obligation.

<b>ELECTRIC</b>		<b>VOLTAGE AVAILABLE*</b>		208-600v/3ø /3, 4w 50/60 Hz					
		<b>AIR FLOW</b>		1,700 cfm		48.1 cmm			
				<b>Oven Size</b>					
				60 Kw		205,000 btu/hr		51,620 kcal/hr	
<b>STEAM</b>		<b>VOLTAGE AVAILABLE**</b>		208-600v/3ø /3, 4w 50/60 Hz					
		<b>AIR FLOW</b>		1,700 cfm		48.1 cmm			
		<b>AIR FLOW SUPER STEAM</b>		2,500 cfm		70.8 cmm			
				<b>Operating Steam Pressure</b>		<b>Steam Supply</b>		<b>Steam Return</b>	
		Standard Steam	LO	15 PSI	1.05 kg/sq cm	1"	2.54 cm	1/2"	1.27 cm(2)
			HI	125 PSI	8.79 kg/sq cm	1"	2.54 cm	1/2"	1.27 cm(2)
		Super Steam	LO	15 PSI	1.05 kg/sq cm	1"	2.54 cm	1/2"	1.27 cm(2)
			HI	125 PSI	8.79 kg/sq cm	1"	2.54 cm	1/2"	1.27 cm(2)
				<b>Steam Consumption</b>		<b>Boiler HP Normal Load</b>			
		Standard Steam	LO	170 lbs/hr	77 kg/hr	4.7 Bhp			
HI	280 lbs/hr		127 kg/hr	6.5 Bhp					
Super Steam	LO	250 lbs/hr	115 kg/hr	7.0 Bhp					
	HI	420 lbs/hr	191 kg/hr	10.8 Bhp					

\* Refer to the Electrical Service Specification chart on **page 25** for detailed electrical information.

\*\* Refer to the Electrical Service Specification chart on **page 24** for detailed electrical information.

**IMPORTANT: ALL ADS-100 STEAM DRYERS REQUIRE A CLEAN, DRY, REGULATED 80 PSI (+/- 10 PSI) AIR SUPPLY.**

*Shaded areas are in metric equivalents.*

**NOTE: ADC reserves the right to make changes in specifications at any time, without notice or obligation.**

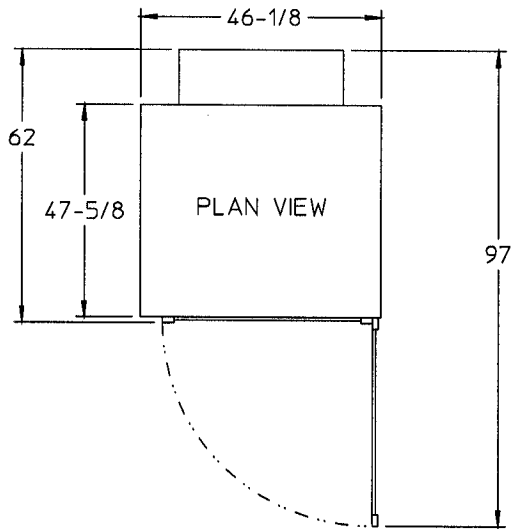

Dryer Model	Dimension "A"	Dimension "B"
Gas		
Electric	8-1/8"	14-9/16"
Lo/Hi Pressure Steam		
Super Steam	8-7/16"	9-3/4"

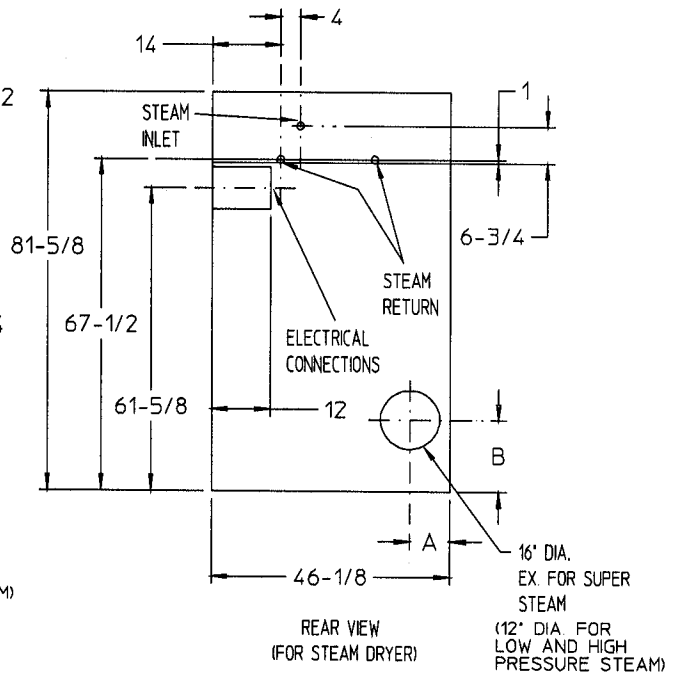
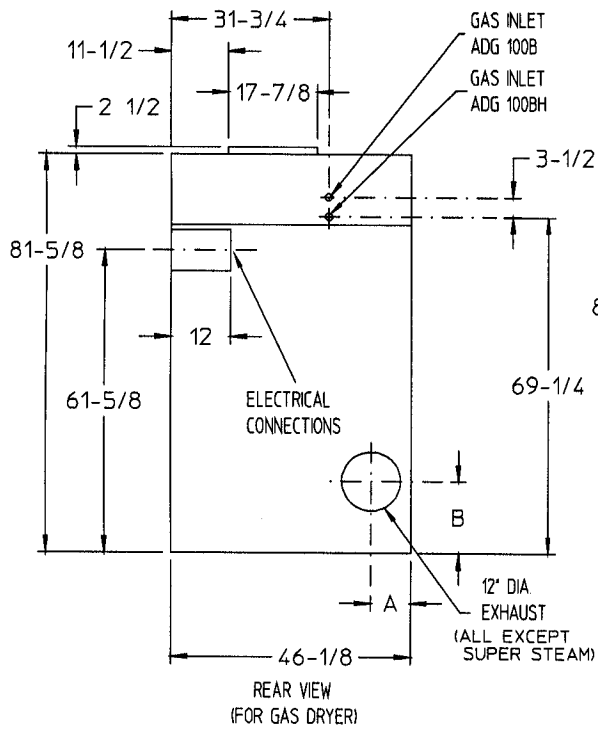

MAN1180

**B. COMPONENT IDENTIFICATION**

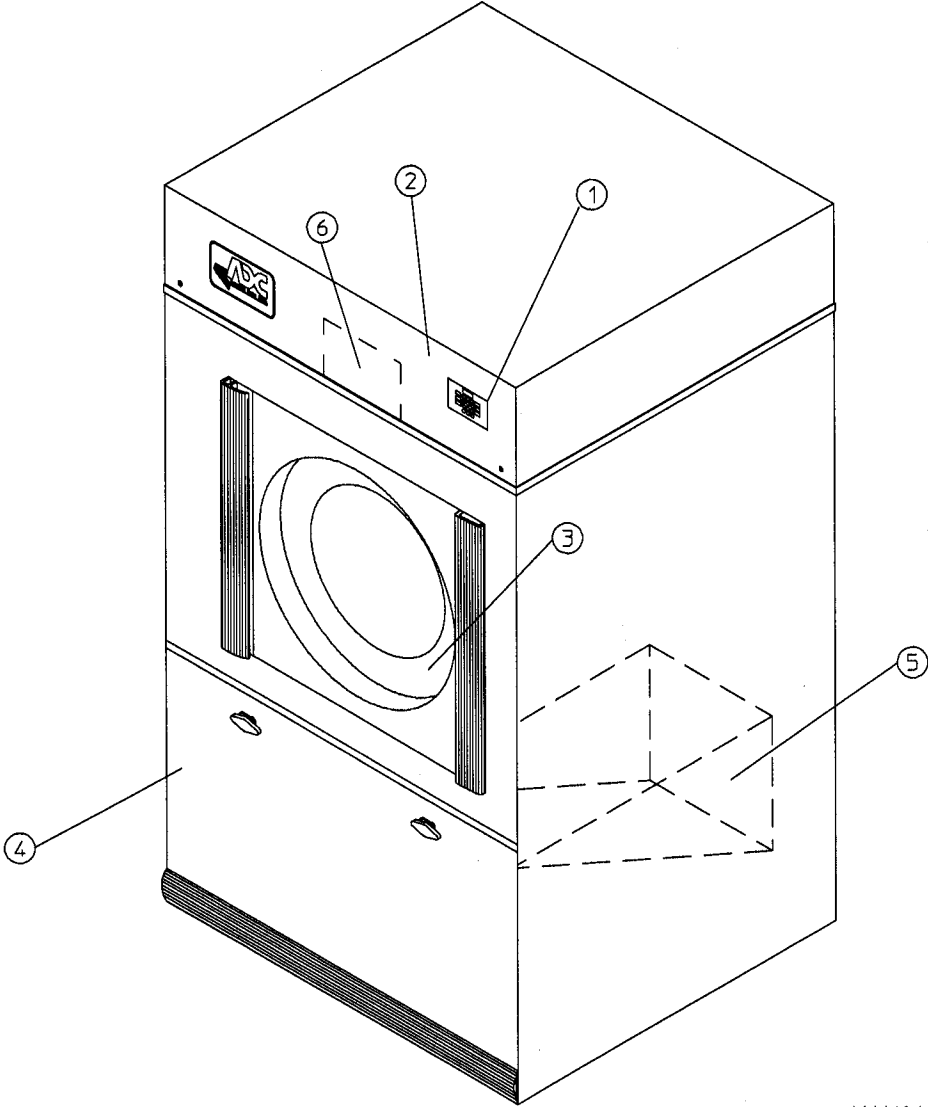

MAN0115

<b>AD-100 FRONT VIEW</b>	
<b>1.</b>	<b>Control Panel Assembly</b>
a.	Microprocessor (computer) Controls
b.	Dual Timer Controls (not illustrated)
<b>2.</b>	<b>Control Door Assembly</b>
<b>3.</b>	<b>Front Panel Assembly and Main Door Assembly</b>
<b>4.</b>	<b>Lint Door Assembly</b>
<b>5.</b>	<b>Lint Coop/Thermostat Bracket Assembly</b>
<b>6.</b>	<b>Wiring Schematic (behind control door assembly)</b>

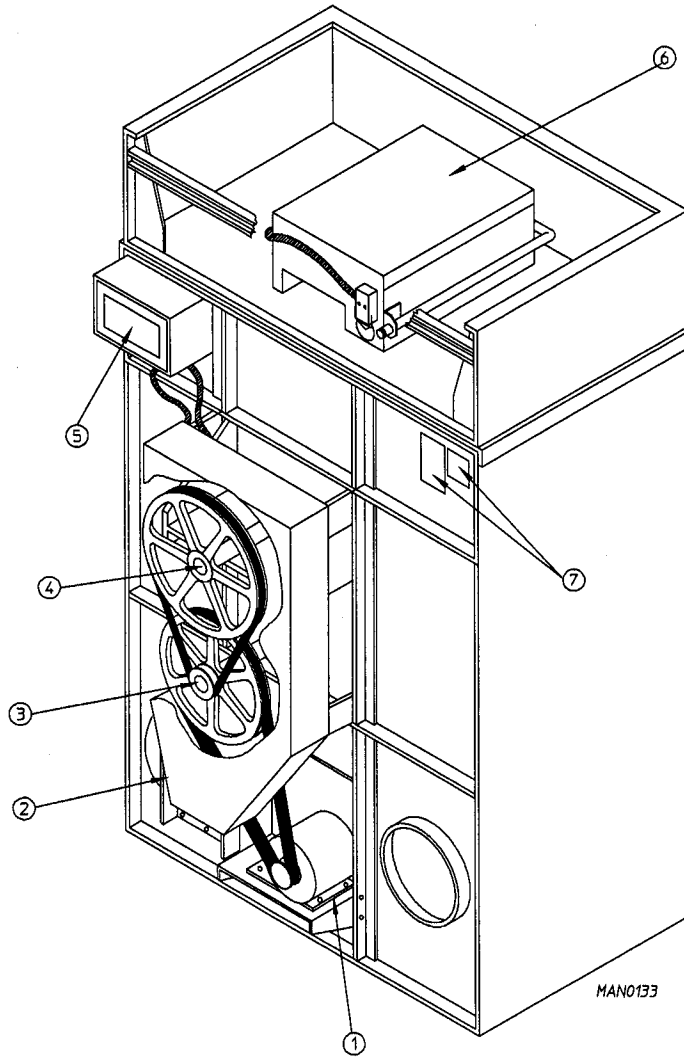

### AD-100 REAR VIEW

1. Basket (tumbler) Motor Mount Assembly
2. Blower Motor Mount Assembly (behind belt guard assembly)
3. Idler Bearing Mount Assembly
4. Tumbler Bearing Mount Assembly
5.* Motor Relay Box Assembly
a. Reversing Microprocessor Controller (computer)
b. Reversing Dual Timer
c. Non-Reversing
6. Heat Assembly (Gas/Electric/Steam)
7. Data Label and Installation Labels

\* Electric service connections for GAS MODELS and STEAM MODELS are made at this location.

# SECTION III

## INSTALLATION PROCEDURES

Installation **should be** performed by competent technicians in accordance with local and state codes. In the absence of these codes, installation **must conform** to applicable American National Standards: National Fuel Gas Code ANSI.Z223.1-LATEST EDITION and/or National Electrical Code ANSI/NFPA NO. 70-LATEST EDITION.

### A. UNPACKING/SETTING UP

Remove protective shipping material (i.e., polyethylene cover, shipping corners, and/or optional shipping box) from the dryer.

**IMPORTANT:** Dryer **must be** transported and handled in an upright position at all times.

The dryer can be moved to its final location while still attached to the skid or with the skid removed. To un-skid the dryer, locate and remove the four (4) lag bolts securing the base of the dryer to the wooden skid. Two (2) are located at the rear base, and two (2) are located in the bottom of the lint chamber. To remove the two (2) lag bolts located in the lint chamber area, remove lint drawer and the two (2) Phillips head screws securing lint door in place.

The lint coop is supported during shipping by a bracket. Remove this bracket before starting the dryer.

**NOTE:** The lint door **cannot** be removed totally from dryer due to a safety chain. The chain is secured to the dryer/ door with special tamper proof screws. The safety chain **must not** be removed or cut from the lint door. Once these lag bolts are off, remove the eight (8) nuts and bolts holding the skid together and take the skid apart. The dryer can now be removed from the skid and set into place.

The V-belts are disconnected from the basket (tumbler) drive motor for shipping. Reconnect these V-belts before starting the dryer.

## B. LOCATION REQUIREMENTS

Before installing the dryer, be sure the location conforms to local codes and ordinances. In the absence of such codes or ordinances the location **must conform** with the National Fuel Gas Code ANSI Z223.1-LATEST EDITION.

1. The dryer **must be** installed on a sound level floor capable of supporting its weight. It is recommended that carpeting be removed from the floor area that the dryer is to rest on.
2. The dryer **must not be** installed or stored in an area where it will be exposed to water and/or weather.
3. This dryer is for use in noncombustible locations.
4. Provisions for adequate air supply **must be** provided as noted in this manual (refer to **Fresh Air Supply** in **Subsection D**).
5. Clearance provisions **must be** made from combustible construction as noted in this manual (refer to **Dryer Enclosure Requirements** in **Subsection C**).
6. Provisions **must be** made for adequate clearances for servicing and for operation as noted in this manual (refer to **Dryer Enclosure Requirements** in **Subsection C**).
7. Dryer **must be** exhausted to the outdoors (refer to **Exhaust Requirements** in **Subsection E**).
8. Dryer **must be** located in an area where correct exhaust venting can be achieved as noted in this manual (refer to **Exhaust Requirements** in **Subsection E**).

**IMPORTANT:** The dryer should be located where a minimum amount of exhaust duct will be necessary.

If more headroom is required when moving the dryer into position, the top console may be removed (as shown in the adjoining [Front View] illustration).

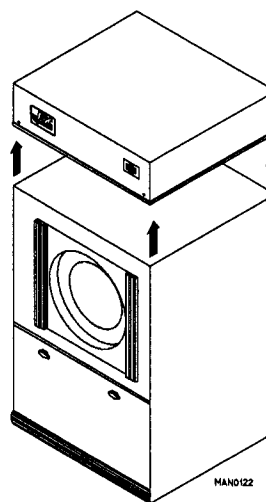

Front View

- a. Disconnect the ground wire (A) at the rear of the dryer. Refer to the adjoining (Rear View) illustration.
- b. Remove the six (6) nuts (B) holding the console to the base. Refer to the illustration (Top [cut-away] View) below.

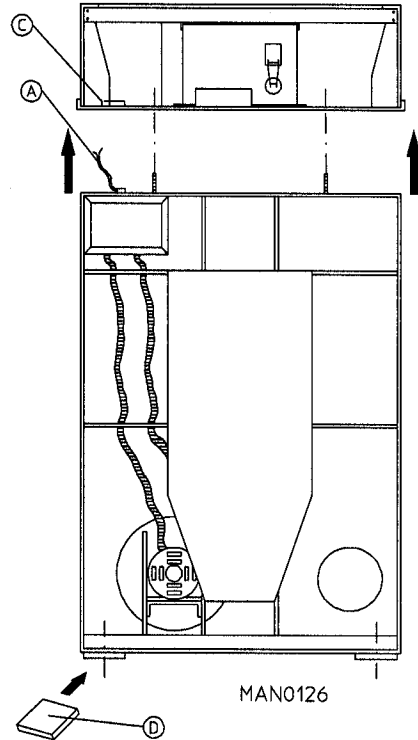

Rear View

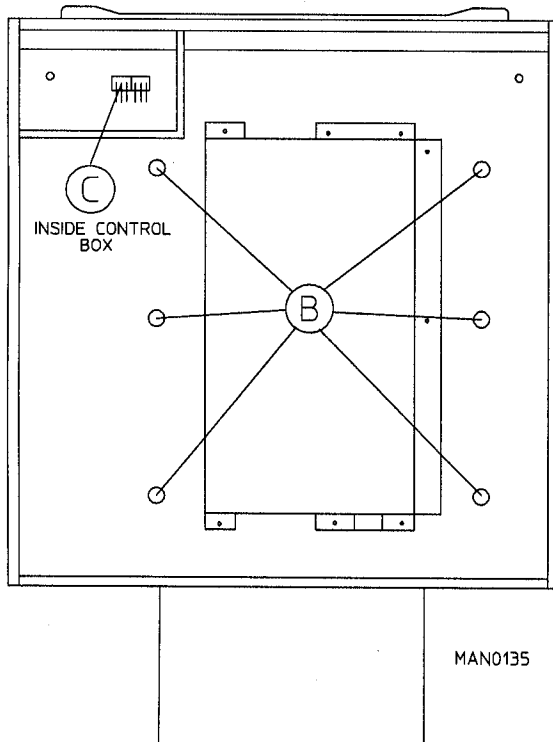

Top (cut-away) View

- c. Open the control door and disconnect the white 15-pin plug (C) located at the bottom of the control box (refer to both illustrations).
- d. Lift the console off of the base. Refer to the illustration (Rear View) above
- e. To level the dryer, place 4-inch square metal shims (D) or other suitable material under the base. Refer to the illustration (Rear View) above.



## C. DRYER ENCLOSURE REQUIREMENTS

Even though a 12-inch clearance is acceptable, it is recommended that the rear of the dryer (from the backguard) be positioned approximately two (2) feet (24-inches) from nearest obstruction (i.e., wall) for ease of installation, maintenance, and service. Bulkheads and partitions **should be made from noncombustible materials**. The clearance between the bulkhead header and the dryer **must be a minimum of 2-inches** and **must not extend more than 4-inches** to the rear of the dryer front. If desired, the bulkhead facing may be closed in all the way to the top of the dryer.

**NOTE:** Bulkhead facing **should not be installed** until after dryer is in place. Ceiling area **must be located a minimum of 6-inches** above the dryer top console (module).

### DRYER ENCLOSURE CLEARANCE TO ADJACENT WALL STRUCTURES

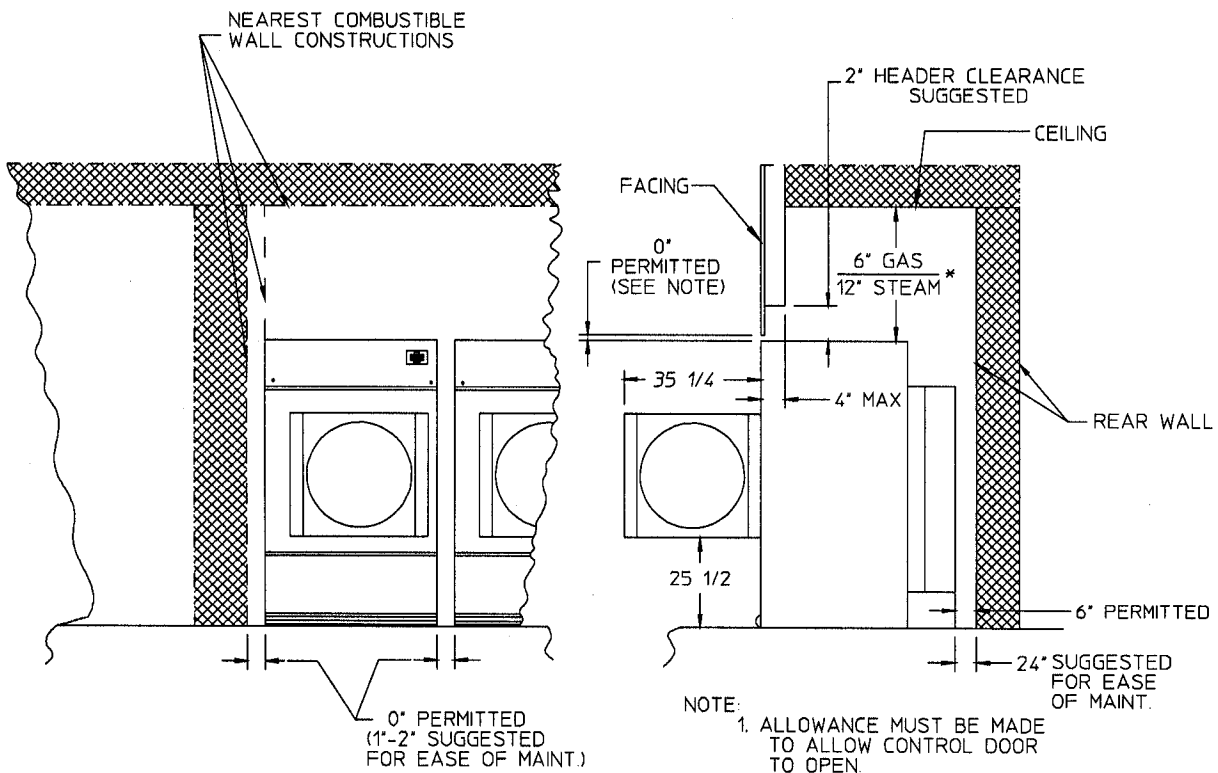

\*12" OR MORE (18" OR MORE FOR STEAM) CLEARANCE IS SUGGESTED, ESPECIALLY IN CASES WHERE SPRINKLER HEADS ARE OVER THE DRYERS.

MAN1181

It is suggested that the dryer be positioned approximately 2 feet (24-inches) away from the nearest rear obstruction for ease of installation, maintenance, and service.

**IMPORTANT:** Even though a minimum of only 6-inches is required, 12-inches or more is suggested, especially in cases where sprinkler heads are over the dryers.

**NOTE:** Even though a minimum of 6-inches above the dryer console (module) is acceptable, a clearance of 12-inches or more is suggested for ease of installation and service.

**NOTE:** When fire sprinkler systems are located above the dryers, a minimum of 12-inches above the dryer console (module) is required. Dryers may be positioned side wall to side wall however, 1 or 2-inches is suggested between dryers (or wall) for ease of installation and maintenance. Allowances **must be** made for the opening and closing of the control door and lint door.

## D. FRESH AIR SUPPLY

When the dryer is operating, it draws in room air, heats it, passes this air through the basket (tumbler), and exhausts it out of the building. Therefore, the room air **must be** continually replenished from the outdoors. If the make-up air is inadequate, drying time and drying efficiency will be adversely affected. Ignition problems and sail switch "fluttering" problems may result, as well as premature motor failure from overheating.

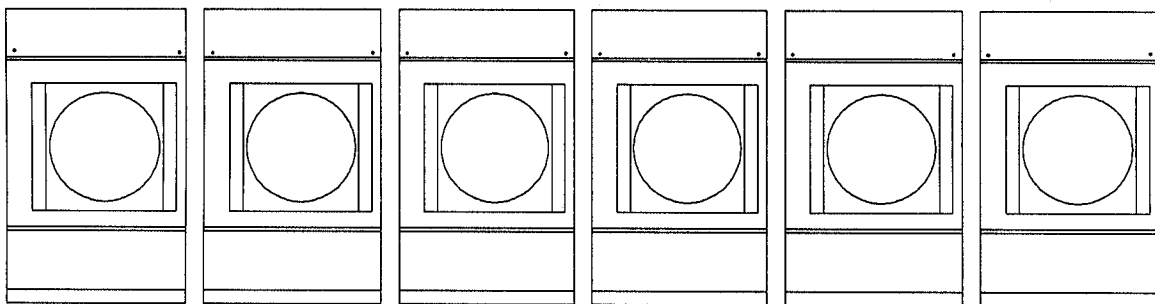

TYPICAL INSTALLATION SHOWING MAKE-UP AIR OPENINGS

MAN0123

Air supply (make-up air) **must be** given careful consideration to assure proper performance of each dryer. An unrestricted source of air is necessary for each dryer. An air flow of 1,750 cfm (cubic feet per minute) **must be** supplied to each gas dryer, electric dryer, and steam dryer, except the super steam dryer which requires 2,500 cfm (cubic feet per minute). As a general rule, an unrestricted air entrance from the outdoors (atmosphere) of a minimum of three (3) square feet is required for each dryer, and a minimum of five (5) square feet is required for for the super steam model dryer.

To compensate for the use of registers or louvers used over the openings, this make-up air area **must be** increased by approximately thirty-three (33) percent. Make-up air openings **should not** be located in an area directly near where exhaust vents exit the building.

It is not necessary to have a separate make-up air opening for each dryer. Common make-up air openings are acceptable. However, they **must be** set up in such a manner that the make-up air is distributed equally to all the dryers.

EXAMPLE: For a bank of six (6) gas dryers, two (2) openings measuring 3 feet by 3 feet (18 square feet) is acceptable.

Allowances **must be** made for remote or constricting passageways or where dryers are located at excessive altitudes or predominantly low pressure areas.

**IMPORTANT:** Make-up air **must be** provided from a source free of dry cleaning solvent fumes. Make-up air that is contaminated by dry cleaning solvent fumes will result in irreparable damage to motors and other dryer components.

**NOTE:** Component failure due to dry cleaning solvent fumes will VOID THE WARRANTY.

## E. EXHAUST REQUIREMENTS

### 1. GENERAL EXHAUST DUCT WORK INFORMATION

Exhaust duct work **should be** designed and installed by a qualified professional. Improperly sized duct work will create excessive back pressure which results in slow drying, increased use of energy, over-heating of the dryer, and shutdown of the burner by the air flow (sail) switches, burner hi-limits, or basket (tumbler) hi-heat thermostats.

**CAUTION: DRYER MUST BE EXHAUSTED TO THE OUTDOORS.**

**CAUTION: IMPROPERLY SIZED OR INSTALLED EXHAUST DUCT WORK CAN CREATE A POTENTIAL FIRE HAZARD.**

**NOTE:** When a dryer is exhausted separately, it is recommended that a back draft damper be installed.

**NOTE:** When dryers are exhausted into a multiple (common) exhaust line, each dryer **must** be supplied with a back draft damper.

The duct work **should be** laid out in such a way that the duct work travels as directly as possible to the outdoors with as few turns as possible. Single or independent dryer venting is recommended.

When single dryer venting is used, the duct work from the dryer to the outside exhaust outlet **should not** exceed twenty (20) feet. In the case of multiple (common) dryer venting, the distance from the last dryer to the outside exhaust outlet **should not** exceed twenty (20) feet. The shape of the duct work is not critical so long as the minimum cross section area is provided. It is suggested that the use of 90° turns in the ducting be avoided; use 30° and/or 45° angles instead. The radius of the elbows should preferably be 1-1/2 times the diameter of the duct. Excluding basket/dryer elbow connections or elbows used for outside protection from the weather, no more than two (2) elbows **should be** used in the exhaust duct run. If more than two (2) elbows are used, the cross section area of the duct work **must be** increased in proportion to number of elbows added.

All duct work **should be** smooth inside with no projections from sheet metal screws or other obstructions which will collect lint. When adding ducts, the duct to be added should overlap the duct to which it is to be connected. All duct work joints **must be** taped to prevent moisture and lint from escaping into the building. Inspection doors **should be** installed at strategic points in the exhaust duct work for periodic inspection and clean-out of lint from the duct work.

**IMPORTANT:** Exhaust back pressure measured by a manometer at each basket (tumbler) exhaust duct area **should not** exceed 0.3 inches of water column.

**NOTE:** Where the exhaust duct work passes through a wall, ceiling, or roof made of combustible materials, the opening **must be** 2-inches larger (all the way around) than the duct. The duct **must be** centered within this opening.

#### A) OUTSIDE DUCT WORK PROTECTION

- 1) To protect the outside end of horizontal duct work from the weather, a 90° elbow bent downward **should be** installed where the exhaust exits the building. If the duct work travels vertically up through the roof, it **should be** protected from the weather by using a 180° turn to point the opening downward. In either case, allow at least twice the diameter of the duct between the duct opening and the nearest obstruction. (Refer to the illustration on **page 18.**)

**IMPORTANT:** Do not use screens or caps on the outside of opening of exhaust duct work.

## 2. SINGLE DRYER VENTING

### VERTICAL DUCTING

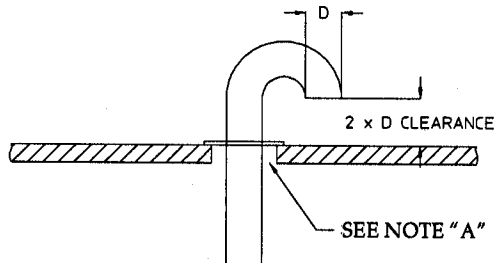

### HORIZONTAL DUCTING

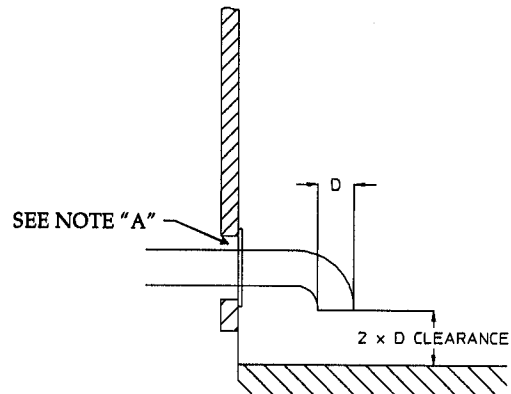

NOTE "A" OPENING MUST BE TWO (2) INCHES LARGER THAN THE DUCT (all the way around). THE DUCT MUST BE CENTERED WITHIN THIS OPENING.

MAN0731

Where possible, it is suggested to provide a separate exhaust duct for each dryer. The exhaust duct **should be** laid out in such a way that the duct work travels as directly as possible to the outdoors with as few turns as possible. It is suggested that the use of 90° turns in ducting be avoided; use 30° and/or 45° angles instead. The shape of the exhaust duct work is not critical so long as the minimum cross section area is provided.

**IMPORTANT:** Minimum duct size for a gas dryer is 12-inches for a round duct or 10.50" x 10.75" for a square duct. The minimum duct size for a steam dryer is 16-inches for a round duct or 14.50" x 14.50" for a square duct. Duct size **must not** be reduced anywhere down stream of dryer.

**IMPORTANT:** Exhaust back pressure measured by a manometer at each basket (tumbler) exhaust duct area **should not** exceed 0.3 inches of water column.

It is suggested that the duct work from each dryer not exceed twenty (20) feet with no more than two (2) elbows (excluding dryer connections and outside exhaust outlets). If the duct work exceeds twenty (20) feet or has numerous elbows, the cross section area of the duct work **must be** increased in proportion to the length and number of elbows in it. In calculating duct size, the cross section area of a square or rectangular duct **must be** increased by twenty (20) percent for each additional twenty (20) feet. The diameter of a round exhaust duct **should be** increased ten (10) percent for each additional fifteen (15) feet. Each 90° elbow is equivalent to an additional fifteen (15) feet, and each 45° elbow is equivalent to an additional ten (10) feet.

## SINGLE DRYER VENTING

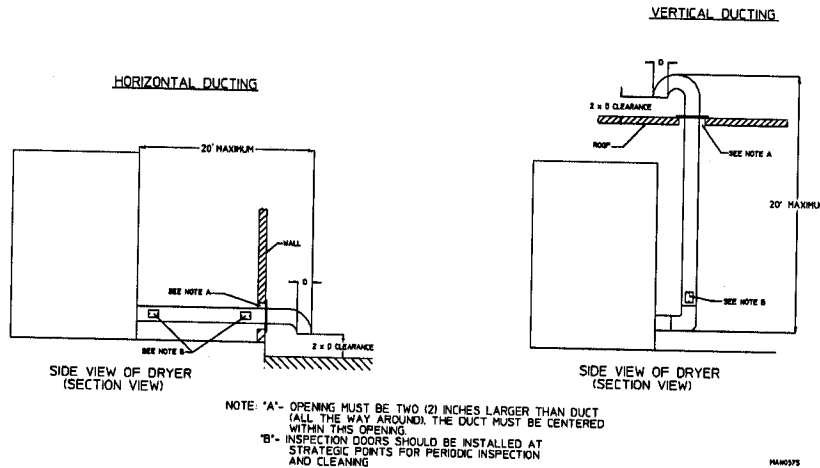

**IMPORTANT:** For extended duct work runs, the cross section area of the duct work can only be increased to an extent. Maximum proportional duct work runs **cannot** exceed twenty (20) feet more than the original limitations of twenty (20) feet with two (2) elbows. When the duct work approaches the maximum limit as noted in this manual, a professional heating venting air conditioning (HVAC) firm **should be consulted** for proper venting information.

All duct work **should be** smooth inside with no projections from sheet metal screws or other obstructions which will collect lint. When adding ducts, the duct to be added should overlap the duct to which it is to be connected. All duct work joints **must be** taped to prevent moisture and lint from escaping into the building. Inspection doors **should be** installed at strategic points in the exhaust duct work for periodic inspection and clean-out of lint from the duct work.

**NOTE:** Where the exhaust duct passes through a wall, ceiling, or roof made of combustible materials, the opening must be 2-inches larger (all the way around) than the duct. The duct **must be** centered within this opening.

### A) OUTSIDE DUCT WORK PROTECTION

- 1) To protect the outside end of horizontal duct work from the weather, a 90° elbow bent downward **should be** installed where the exhaust exits the building. If the exhaust duct work travels vertically up through the roof, it **should be** protected from the weather by using a 180° turn to point the opening downward. In either case, allow at least twice the diameter of the duct between the duct opening and nearest obstruction.

**IMPORTANT:** Do not use screens, louvers, or caps on the outside of opening of exhaust duct work.

### 3. MULTIPLE DRYER (COMMON) VENTING

If it is not feasible to provide separate exhaust ducts for each dryer, ducts from individual dryers may be channeled into a "common main duct." The individual ducts should enter the bottom or side of the main duct at an angle not more than 45° in the direction of air flow and **should be** spaced at least 46-1/8 inches apart. The main duct **should be** tapered, with the diameter increasing before each individual 12-inch (minimum for gas dryers) or 16-inch (minimum for steam dryers) duct is added.

**IMPORTANT:** The AD-100 is not provided with a back draft damper. When exhausted into a multiple (common) exhaust line, a back draft damper **must be** installed at each dryer duct.

**IMPORTANT:** No more than four (4) dryers **should be** connected to one main common duct.

The main duct may be any shape or cross sectional area, so long as the minimum cross section area is provided. The **illustrations on page 21 and page 22** show the minimum cross section area for multiple dryer round or square venting. These figures **must be** increased 10 square inches when rectangular main ducting is used, and the ratio of duct width to depth **should not be** greater than 3-1/2 to 1. These figures **must be** increased in proportion if the main duct run to the last dryer to where it exhausts to the outdoors is unusually long (over twenty [20] feet) or has numerous elbows (more than two [2]) in it. In calculating duct work size, the cross section area of a square or rectangular duct **must be** increased twenty (20) percent for each additional twenty (20) feet. The diameter of a round exhaust **must be** increased ten (10) percent for each additional twenty (20) feet. Each 90° elbow is equivalent to an additional fifteen (15) feet and each 45° elbow is equivalent to an additional ten (10) feet.

**IMPORTANT:** For extended duct work runs, the cross section area of the duct work can only be increased to an extent. Maximum proportional duct work runs **cannot** exceed twenty (20) feet more than the original limitations of twenty (20) feet with two (2) elbows. When the duct work approaches the maximum limits as noted in this manual, a professional HVAC firm **should be** consulted for proper venting information.

**IMPORTANT:** Exhaust back pressure measured by a manometer at each dryer exhaust duct area **should not** exceed 0.3 inches of water column.

The duct work **should be** smooth inside with no projections from sheet metal screws or other obstructions which will collect lint. When adding ducts, the duct to be added should overlap the duct to which it is to be connected. All duct work joints **must be** taped to prevent moisture and lint from escaping into the building. Inspection doors **should be** installed at strategic points in the exhaust duct work for periodic inspection and clean-out of lint from the duct work.

**NOTE:** Where the exhaust passes through a wall, ceiling, or roof made of combustible materials, the opening **must** be 2-inches larger (all the way around) than the duct. The duct **must** be centered within this opening.

**A) OUTSIDE DUCT WORK PROTECTION**

- 1) To protect the outside end of the horizontal duct work from the weather, a 90° elbow bent downward **should be** installed where the exhaust exits the building. If the exhaust duct work travels vertically up through the roof, it **should be** protected from the weather by using a 180° turn to point the opening downward. In either case, allow at least twice the diameter of the duct between the duct opening and nearest obstruction.

**IMPORTANT:** Do not use screens, louvers, or caps on the outside of opening of exhaust duct work.

**MULTIPLE DRYER VENTING (ADG-100 — ADE-100 — ADS-100)  
WITH 12" DIAMETER (1,700 cfm) EXHAUST CONNECTIONS AT COMMON DUCT**

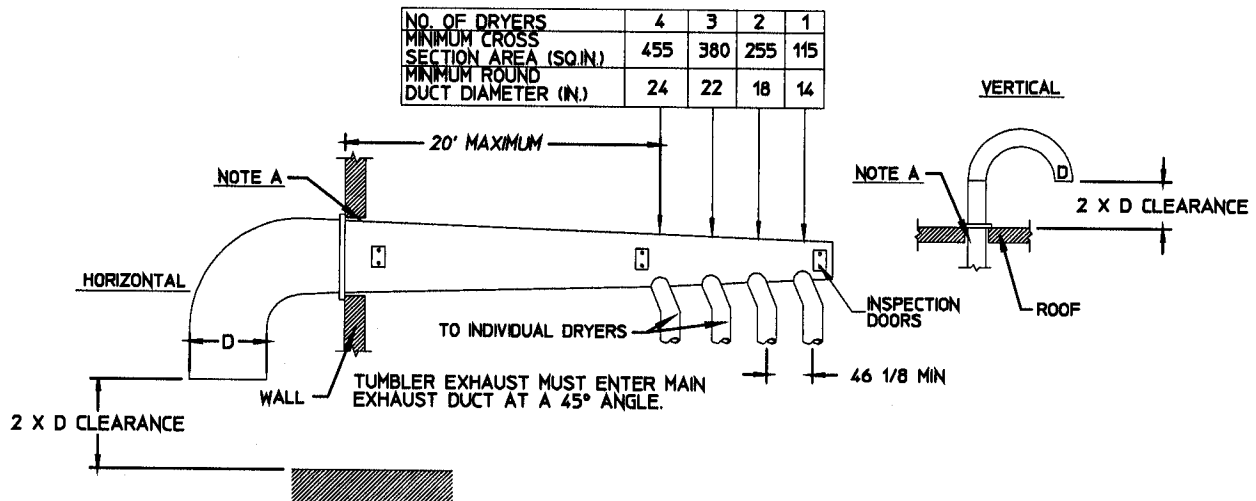

**IMPORTANT:** NO MORE THAN 4 DRYERS CAN BE CONNECTED TO ONE COMMON DUCT ( VENT ).

**FORMULAS TO CALCULATE DUCTING CROSS SECTIONAL AREA**

CROSS SECTIONAL AREA OF A ROUND DUCT =  $.785 \times D^2$  WHERE D = DIAMETER OF THE DUCT.

CROSS SECTIONAL AREA OF A RECTANGULAR DUCT =  $W \times H$  WHERE W = WIDTH AND H = HEIGHT.

**NOTE A:** OPENING MUST BE TWO (2) INCHES LARGER THAN DUCT (ALL THE WAY AROUND). THE DUCT MUST BE CENTERED WITHIN THIS OPENING.



MULTIPLE DRYER VENTING (ADG-100 with HEAT RECLAIMER)  
WITH 12" DIAMETER (1,060 cfm) EXHAUST CONNECTIONS AT COMMON DUCT

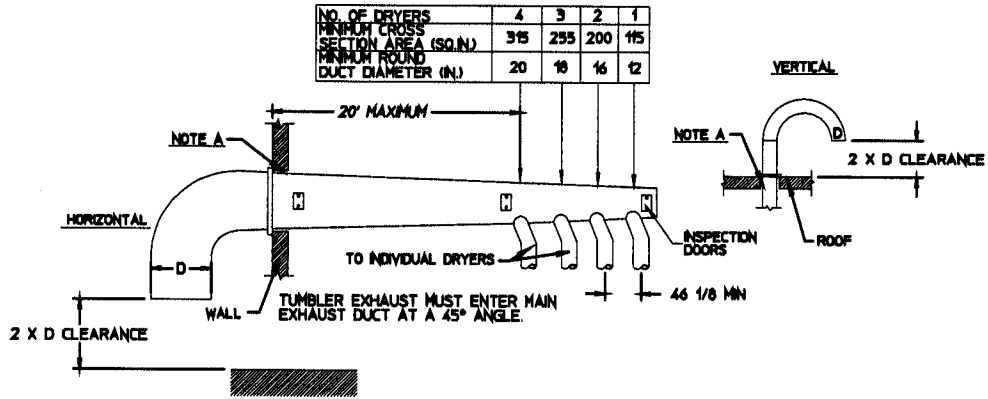

IMPORTANT: NO MORE THAN 4 DRYERS CAN BE CONNECTED TO ONE COMMON DUCT ( VENT ).

**FORMULAS TO CALCULATE DUCTING CROSS SECTIONAL AREA**

CROSS SECTIONAL AREA OF A ROUND DUCT -  $.785 \times D^2$  WHERE D = DIAMETER OF THE DUCT.

CROSS SECTIONAL AREA OF A RECTANGULAR DUCT -  $W \times H$  WHERE W = WIDTH AND H = HEIGHT.

NOTE A: OPENING MUST BE TWO (2) INCHES LARGER THAN DUCT (ALL THE WAY AROUND). THE DUCT MUST BE CENTERED WITHIN THIS OPENING.

121692WL

MAN1174

MULTIPLE DRYER VENTING (ADS-100 - SUPER STEAM)  
WITH 16" DIAMETER (2,500 cfm) EXHAUST CONNECTIONS AT COMMON DUCT

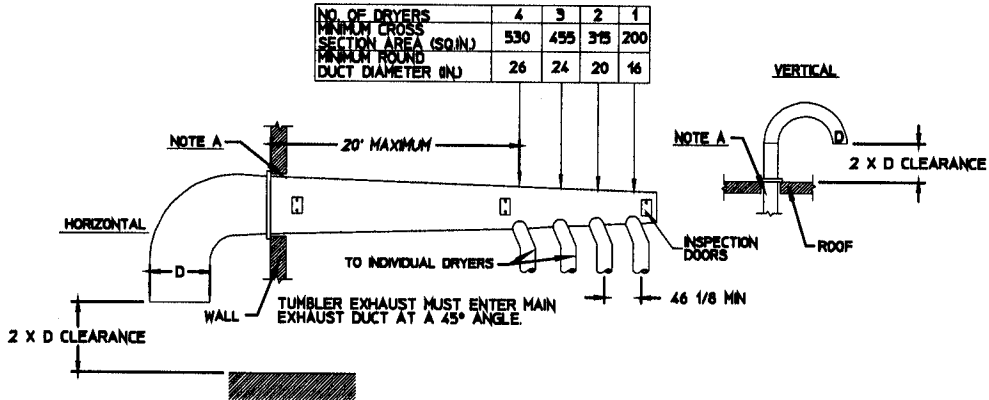

IMPORTANT: NO MORE THAN 4 DRYERS CAN BE CONNECTED TO ONE COMMON DUCT ( VENT ).

**FORMULAS TO CALCULATE DUCTING CROSS SECTIONAL AREA**

CROSS SECTIONAL AREA OF A ROUND DUCT -  $.785 \times D^2$  WHERE D = DIAMETER OF THE DUCT.

CROSS SECTIONAL AREA OF A RECTANGULAR DUCT -  $W \times H$  WHERE W = WIDTH AND H = HEIGHT.

NOTE A: OPENING MUST BE TWO (2) INCHES LARGER THAN DUCT (ALL THE WAY AROUND). THE DUCT MUST BE CENTERED WITHIN THIS OPENING.

121692WL

MAN1173

## F. ELECTRICAL INFORMATION

### 1. ELECTRICAL REQUIREMENTS

It is your responsibility to have all electrical connections made by a properly licensed and competent electrician to assure that the electrical installation is adequate and conforms with local and state regulations or codes. In the absence of such codes, all electrical connections, material, and workmanship **must conform** to the applicable requirements of the National Electrical Code ANSI/NFPA NO. 70-LATEST EDITION.

**IMPORTANT:** Failure to comply with these codes or ordinances, and/or the requirements stipulated in this manual can result in personal injury or component failure.

**NOTE:** Component failure due to improper installation will VOID THE WARRANTY.

Each dryer **should be** connected to an independently protected branch circuit. The dryer **must be** connected with copper wire only. **Do not** use aluminum wire which could cause a fire hazard. The copper conductor wire/cable **must be** of proper ampacity and insulation in accordance with electric codes for making all service connections.

**NOTE:** On ADG-100 dryers, to convert from 208 VAC to 230/240 VAC (or vice versa), the Direct Spark Ignition (DSI) transformer wiring **must be** changed as explained in **Section IV, page 53 and page 54**. On ADS-100 dryers, the steam damper motor **must be** changed.

**NOTE:** The use of aluminum wire will VOID THE WARRANTY.

A) ELECTRICAL SERVICE SPECIFICATIONS

## ADG / ADS-100 Reversing, 3Ø Motor

### Electrical Service Specifications (Per Dryer)

**IMPORTANT:** 208 VAC and 230/240 VAC are not the same. When ordering, specify exact voltage.

**NOTES:** A. Fuse ratings are dual element-time delay- current limiting, class RK1 or RK5 **ONLY**.  
 B. Circuit breakers are thermal magnetic (industrial) type **ONLY**. For others, calculate/verify correct breaker size according to appliance amp draw rating and type of breaker used.  
 C. Circuit breakers for 3Ø dryers **must be** 3-pole type.

SERVICE VOLTAGE	PHASE	WIRE SERVICE	APPROX. AMP DRAW	MINIMUM WIRE SIZE*	FUSING Dual Element Time Delay	CIRCUIT BREAKER
208	3Ø	3	6.7	14	9	15
230/240	3Ø	3	6.8	14	9	15
380	3Ø	3	4.1	14	5.6	15
380	3Ø	4	4.1	14	5.6	15
416	3Ø	3	4.3	14	5.6	15
416	3Ø	4	4.3	14	5.6	15
460	3Ø	3	3.9	14	5	15
460	3Ø	4	3.9	14	5	15
480	3Ø	3	3.9	14	5	15
480	3Ø	4	3.9	14	5	15
575/600	3Ø	3	3.4	14	4.5	15

\* AWG Stranded Type Wire...for individual lengths less than 100 feet.

**NOTE:** ADC reserves the right to make changes in specifications at any time, without notice or obligation.

**IMPORTANT:** The dryer **must be** connected to the electrical supply shown on the data label that is affixed to the back of the dryer, at the upper right hand corner. In the case of 208 VAC or 230/240 VAC, the supply voltage must match the electric service specifications of the data label exactly.

**WARNING:** 208 VAC AND 230/240 VOLTS ARE NOT THE SAME. Any damage done to dryer components due to improper voltage connections will automatically VOID THE WARRANTY.

## ADE-100 Reversing, 3Ø Motor

### Electrical Service Specifications (Per Dryer)

**IMPORTANT:** 208 VAC and 230/240 VAC are not the same. When ordering, specify exact voltage.

**NOTES:** A. Fuse ratings are dual element-time delay- current limiting, class RK1 or RK5 **ONLY**.  
 B. Circuit breakers are thermal magnetic (industrial) type **ONLY**. For others, calculate/verify correct breaker size according to appliance amp draw rating and type of breaker used.  
 C. Circuit breakers for 3Ø dryers **must be** 3-pole type.

OVEN SIZE (Kw)	SERVICE VOLTAGE	PHASE	WIRE SERVICE	APPROX. AMP DRAW	MINIMUM WIRE SIZE*	FUSING	CIRCUIT BREAKER
						Dual Element Time Delay	
60	208	3Ø	3	173.9	4	200	200
60	240	3Ø	3	151.8	4	175	175
60	380	3Ø	3	95.9	6	100	100
60	380	3Ø	4	95.9	6	100	100
60	416	3Ø	3	88.2	8	90	100
60	416	3Ø	4	88.2	8	90	100
60	480	3Ø	3	76.2	8	80	80
60	480	3Ø	4	76.2	8	80	80
60	575/600	3Ø	3/4	62.1	10	70	70

\* AWG Stranded Type Wire...for individual lengths less than 100 feet.  
 (Motor lead type of wire is recommended.)

**NOTE:** ADC reserves the right to make changes in specifications at any time, without notice or obligation.

**IMPORTANT:** The dryer **must be** connected to the electrical supply shown on the data label that is affixed to the back of the dryer, at the upper right hand corner. In the case of 208 VAC or 230/240 VAC, the supply voltage must match the electric service specifications of the data label exactly.

**WARNING:** 208 VAC AND 230/240 VOLTS ARE NOT THE SAME. Any damage done to dryer components due to improper voltage connections will automatically VOID THE WARRANTY.

## B) ELECTRICAL CONNECTIONS

**NOTE:** A wiring diagram is included with each dryer and is affixed to the rear, upper right hand corner of the dryer. (Refer to **Section II, page 10.**)

The only electrical input connections to the dryer are the 3-phase (3 $\phi$ ) power leads (L1, L2, and L3), GROUND, and in the case of 4 wire service, the neutral. These electrical connections are made at the wire leads located in the electrical service/relay box at the rear, upper left hand corner of the dryer. To gain access into this service/relay box, the service cover **must** be removed.

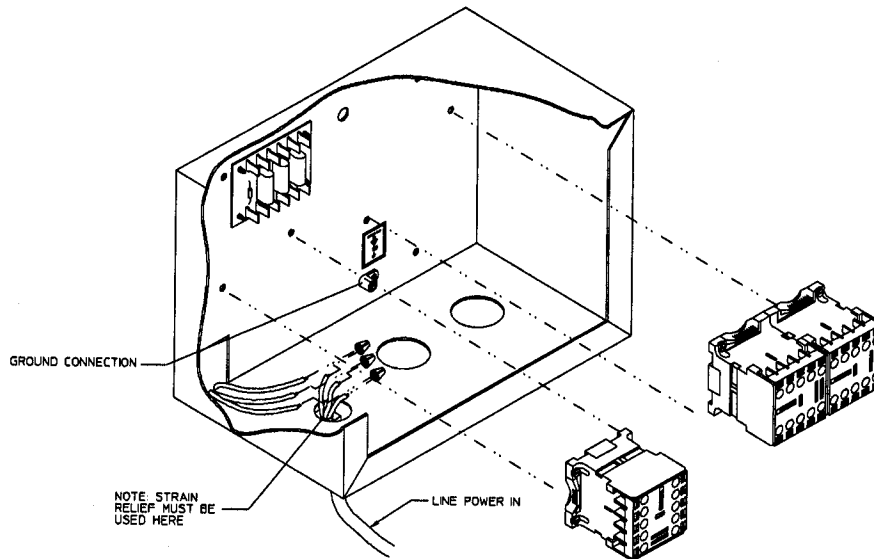

Providing local codes permit, power connections to the dryer can be made by the use of a flexible underwriters laboratory listed cord/pigtail (wire size **must conform** to rating of the dryer), or the dryer can be hard wired directly to the service breaker. In all cases, a strain relief **must be** used where the wire(s) enter the dryer electrical service (relay) box (as shown in the illustration above).

### 1) GAS MODEL and STEAM MODEL DRYERS

For gas model and steam model dryers, the electrical input connections are made at the wire leads located in the service/relay box at the rear, upper left hand corner of the dryer.

### 2) ELECTRIC MODEL DRYERS

For electric model dryers made to operate at 208 VAC, 230 VAC, or 240 VAC, the electrical input connection is made into the terminal block located at the upper rear of the dryer. For electric model dryers made to operate at 380 VAC, 416 VAC, 440 VAC, or 480 VAC, the electrical input connection is made to the oven relay located at the upper rear of the dryer. input connection wiring **must be** sized properly to handle the dryer's current draw. This information is printed on the dryer's data label which is affixed to the rear, upper right hand corner of the dryer. (Refer to **Section II, page 10.**)

**NOTE: A CIRCUIT SERVING EACH DRYER MUST BE PROVIDED.**

C) GROUNDING

Grounding (earth) connections **must be** provided and installed in accordance with state and local codes. In the absence of these codes, grounding **must conform** to applicable requirements of the National Electric Code ANSI/NFPA NO. 70-LATEST EDITION. The ground connection may be to a proven earth ground at the location service panel.

**NOTE:** A grounding connection (terminal lug) is provided in the dryers electrical service/relay box at the rear, upper left hand corner of the dryer. (Refer to **illustration on page 26.**)

For added personal safety, when possible, it is suggested that a separate ground wire (sized per local codes) be connected from the ground connection of the dryer to a grounded cold water pipe. **Do not** ground to a gas or hot water pipe. The grounded cold water pipe **must have** metal to metal connections all the way to electrical ground. If there are any non-metallic interruptions, such as a meter, pump, plastic, rubber, or other insulating connectors, they **must be** jumped out with no. 4 copper wire and securely clamped to bare metal at both ends.

**IMPORTANT:** For personal safety and proper operation, the dryer **must be** grounded. For proper operation of the microprocessor (computer), an earth (zero) ground **is required.**

**NOTE:** Grounding via a metallic electrical conduit (pipe) **is not** recommended.

G. GAS INFORMATION

It is your responsibility to have all plumbing connections made by a qualified professional to assure that the gas plumbing installation is adequate and conforms with local and state regulations or codes. In the absence of such codes, all plumbing connections, material, and workmanship **must conform** to the applicable requirements of the National Fuel Gas Code ANSI Z223.1-LATEST EDITION.

**IMPORTANT:** Failure to comply with these codes or ordinances, and/or the requirements stipulated in this manual, can result in personal injury and improper operation of the dryer.

The dryer and its individual shut-off valve **must be** disconnected from the gas supply piping system during any pressure testing of that system at test pressures in excess of 1/2 psig (3.5 kPa). The dryer **must be** isolated from the gas supply piping system by closing its individual manual shut-off valve during any pressure testing of the gas supply piping system at test pressures equal to or less than 1/2 psig (3.5 kPa).

**IMPORTANT:** Failure to isolate or disconnect dryer from gas supply as noted can cause irreparable damage to the gas valves VOIDING THE WARRANTY.

**WARNING: FIRE OR EXPLOSION COULD RESULT.**

1. GAS SUPPLY

The gas dryer installation **must meet** the American National Standard: National Fuel Gas Code Z223.1-LATEST EDITION, as well as local codes and ordinances and **must be** done by a qualified professional.

**NOTE:** Undersized gas piping will result in ignition problems, slow drying, increased use of energy, and can create a safety hazard.

The dryer **must be** connected to the type of heat/ gas indicated on the dryer data label affixed to the back of the dryer at the upper right hand corner. (Refer to **Section II, page 10.**) If this information **does not agree** with the type of gas available, **do not operate the dryer.** Contact the distributor who sold the dryer or the ADC factory.

**IMPORTANT:** Any burner changes or conversions **must be** made by a qualified professional.

The input ratings shown on the dryer data label are for elevations of up to 2,000 feet, unless elevation requirements of over 2,000 feet were specified at the time the dryer order was placed with the factory. The adjustment or conversion of dryers in the field for elevations over 2,000 feet are made by changing each burner orifice. If this conversion is necessary, contact the distributor who sold the dryer or contact the ADC factory.

2. TECHNICAL GAS DATA

A) GAS SPECIFICATIONS

	TYPE OF GAS	
	Natural	Liquid Propane
Manifold Pressure*	3.5 - 4.0 inches W.C.	10.5 - 11.0 inches W.C.
In-Line Pressure	6.0 to 12.0 inches W.C.	11.0 inches W.C.

\* Measured at the gas valve pressure tap when the gas valve is on.

B) GAS CONNECTIONS:

Inlet Connection ..... 3/4-inch N.P.T. (National Pipe Thread)

Inlet Supply Size ..... 3/4-inch N.P.T. (minimum)

MODEL NUMBER	BTU Per Hour Rating	TYPE OF GAS						L.P. Conversion Kit Part Number
		Natural			Liquid Propane			
		Qty.	D.M.S.*	Part Number	Qty.	D.M.S.*	Part Number	
ADG-100D	265,000	3	#17	140830	3	#36	140816	874028
ADG-100DH	250,000	3	#18	140829	3	#37	140815	874041

\* D.M.S. (Drill Material Size) equivalents are as follows:

Natural Gas ..... #17 = .1730"  
 #18 = .1695"

Liquid Propane Gas ... #36 = .1065"  
 #37 = .1040"

1. NATURAL GAS

Regulation is controlled by the dryers gas valve internal regulator. Incoming supply pressure **must be** consistently between a minimum of 6.0 inches and a maximum of 12.0 inches water column (W.C.) pressure.

2. LIQUID PROPANE (L.P.) GAS

Dryers made for use with L.P. gas have the gas valve's internal pressure regulator blocked open so that the gas pressure **must be** regulated upstream of the dryer. The pressure measured at each gas valve pressure tap **must be** a consistent 11.0 inches water column. There is no regulator or regulation provided in an L.P. dryer. The water column pressure **must be** regulated at the source (L.P. tank) or external regulator/ regulation **must be** added to each dryer.

3. PIPING/CONNECTIONS

All components/ materials **must conform** to national fuel gas code specifications. It is important that gas pressure regulators meet applicable pressure requirements and that gas meters be rated for the total amount of all the appliance Btu's being supplied.

The dryer is provided with a 3/4-inch N.P.T. inlet pipe connection extending out the back area of the burner box. The minimum pipe size connection (supply line) to the dryer is 3/4-inch N.P.T. For ease of servicing, the gas supply line of each dryer **must have** its own shut-off valve.

The size of the main gas supply line (header) will vary depending on the distance this line travels from the gas meter or, in the case of L.P. gas, the supply tank, other gas-operated appliances on the same supply line, etc. Specific information regarding supply line size **should be** determined by the gas supplier.



**NOTE:** Undersized gas supply piping can create a low or inconsistent pressure which will result in erratic operation of the burner ignition system.

Consistent gas pressure is essential at all gas connections. It is recommended that a 1-inch pipe gas loop be installed in the supply line serving a bank of dryers. An in-line pressure regulator **must be** installed in the gas supply line (header) if the (natural) gas pressure exceeds 12.0 inches of water column pressure.

**IMPORTANT:** A water column pressure of 4.0 inches for natural gas and 11.0 inches for L.P. dryers is required at the gas valve pressure tap of each dryer for proper and safe operation.

A 1/8-inch N.P.T. plugged tap, accessible for a test gauge connection, **must be** installed in the main gas supply line immediately upstream of each dryer.

**IMPORTANT:** Pipe joint compounds that resist the action of natural gas and L.P (liquid propane) gases **must be** used.

**IMPORTANT:** Test all connections for leaks by brushing on a soapy water solution (liquid detergent works well).

**WARNING: NEVER TEST FOR GAS LEAKS WITH A FLAME!!!**

All components/materials **must conform** to National Fuel Gas Code Specifications ANSI Z223.1-LATEST EDITION. It is important that gas pressure regulators meet applicable pressure requirements, and that gas meters be rated for the total amount of appliance Btu's being supplied.

**IMPORTANT:** The dryer and its individual shut-off valve **must be** disconnected from the gas supply piping system during any pressure testing of that system at test pressures in excess of 1/2 psig (3.5 kPa).

**NOTE:** The dryer **must be** isolated from the supply piping system by closing its individual manual shut off valve during any pressure testing of the gas supply piping system at test pressures equal to or less than 1/2 psig (3.5 kPa).

TYPICAL NATURAL GAS INSTALLATION

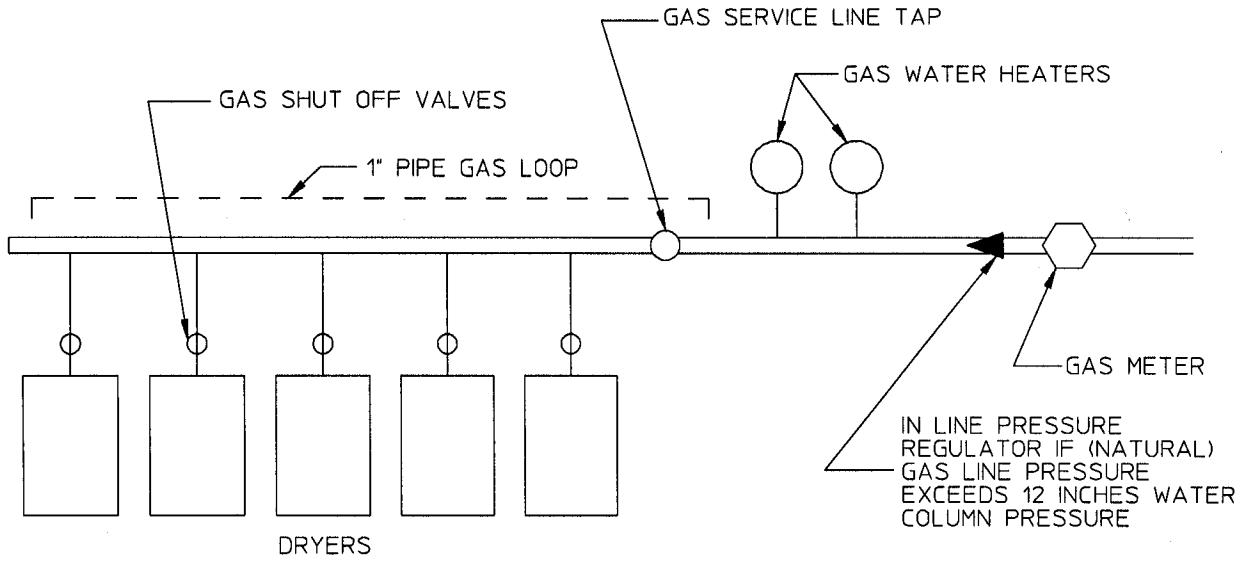

TYPICAL L.P. GAS INSTALLATION

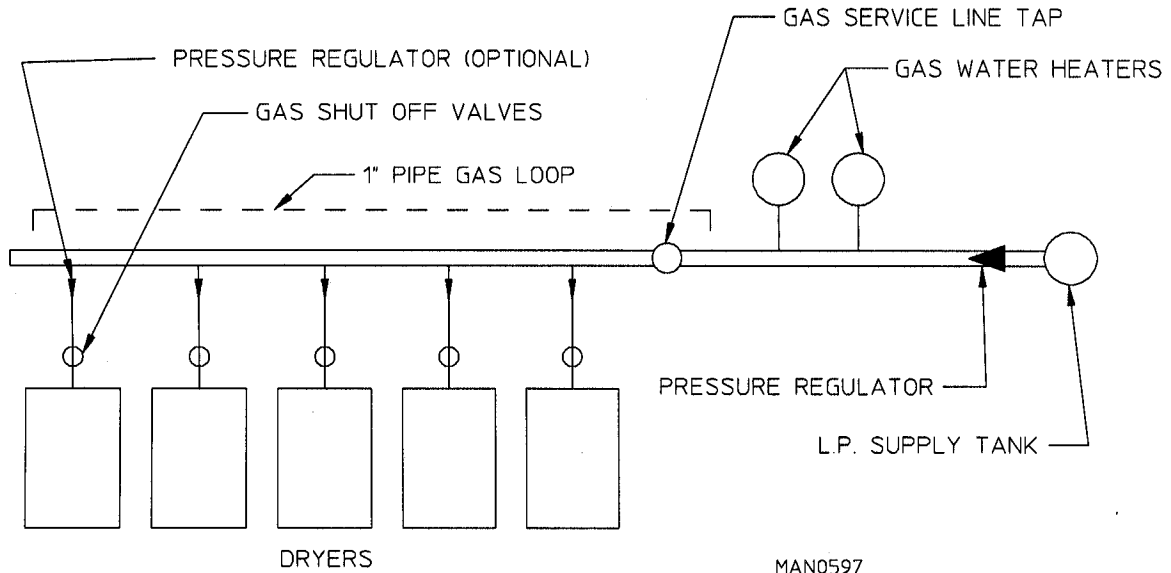

MAN0597

## H. STEAM INFORMATION

It is your responsibility to have all steam plumbing connections made by a qualified professional to assure that the installation is adequate and conforms with local and state regulations or codes.

**IMPORTANT:** Failure to comply with the requirements stipulated in this manual can result in component failure which will VOID THE WARRANTY.

Care **must be** exercised when leveling steam dryers to their final position. After leveling the dryer, check the downward pitch of the heat exchanger from the front to the rear of the dryer with a level. Like

wise, check the downward of the return condensate manifold towards its outlet part. Absence of these downward pitches will result in probable water hammer and premature fracture and leakage.

The presence of condensate in the steam will cause water hammer and subsequent heat exchanger failure. The steam supply connection **must be** taken from the top of a well-dripped steam main. If the supply run-out to the dryer exceeds twenty (20) feet, it **should be** dripped just before the control valve with a proper trap and dirt pocket.

### 1. STEAM REQUIREMENTS

Inlet ..... 1-inch Supply Line Connection ---- Qty. one (1)

Return .. 1/2-inch Return Line Connection — Qty. two (2)

Operating Steam Pressure					
Standard Steam	LO	15 PSI	Super Steam	LO	15 PSI
	HI	125 PSI		HI	125 PSI

Steam Consumption			Boiler HP Normal Load	
Standard Steam	LO	170 lbs/hr	4.7 Bhp	
	HI	280 lbs/hr	6.5 Bhp	
Super Steam	LO	250 lbs/hr	7.0 Bhp	
	HI	420 lbs/hr	10.8 Bhp	

#### A) LOW PRESSURE STEAM (10-15 psig)

Low pressure steam requires oversized piping. The line running from each main to each dryer **must be** 1-1/4-inch pipe.

ADC recommends a Float and Thermostatic (F & T) trap for low pressure steam.

**DO NOT** elevate the condensate return line after the F & T trap. Drain only by gravity into a properly vented low pressure return tank or condensate tank. Locate the steam trap at least 12-inches below coil outlet to assure proper drainage. (Refer to the illustration on **page 34.**)

B) **HIGH PRESSURE STEAM** (100-125 psig)

Steam dryers equipped to operate with high pressure steam require a 1-inch supply line and a 1/2-inch return line.

ADC recommends an inverted bucket trap for high pressure steam dryers.

**| NOTE: DO NOT USE THERMODYNAMIC, DISC, or IMPULSE TRAPS.**

The condensate return line may be elevated after a bucket trap, but only if there is sufficient line pressure to overcome the head. Determine head loss by deducting 12 psi for control valves, coil, and trap losses, and deduct 1/2 psi for each foot of elevation.

Locate the steam trap at least 12-inches below the coil outlet. (Refer to the illustration on **page 34.**)

## 2. **INSTALLATION INSTRUCTIONS**

To insure that an adequate supply of steam is provided, be sure that the steam and steam return lines are sized and laid out as stipulated in this manual. Inadequate steam and steam return lines or improper steam plumbing will result in poor performance and can cause component failure. Clean, dry steam **must** be provided to the dryer.

**| IMPORTANT: Steam coil failure due to water hammer by wet steam VOIDS THE WARRANTY.**

- A) The pressure of the condensate in the steam supply will cause water hammer and subsequent heat exchanger (steam coil) failure. The steam supply connection into the main supply line **must** be made with a minimum 10-inch riser. This will prevent any condensate from draining towards the dryer.
- B) The steam supply piping to the dryer **must include** a 12-inch rise along with a drip trap and check valve. This will prevent any condensate from entering the steam coil.
- C) Flexible hoses or couplings **must be** used. The dryer vibrates slightly when it runs and this will cause the steam coil connections to crack if they are hard piped to the supply and return mains.
- D) Shut-off valves for each dryer **should be** installed in the supply, return, and drip trap return lines. This will allow the dryer to be isolated from the supply and return mains if the dryer needs maintenance work.
- E) Install an inverted bucket steam trap and check valve at least 12-inches below steam coil as close to the coil as possible.

- F) A vacuum breaker **should be** installed in the piping. This will prevent the condensing steam from causing a vacuum inside the coil and possibly damaging the coil.
- G) The supply and return lines **should be** insulated. This will save energy and provide for the safety of the operator and maintenance personnel.
- H) Water pockets in the supply line, caused by low points, will provide wet steam to the coil possibly causing coil damage. All horizontal runs of steam supply piping **should be** pitched 1/4-inch for every one (1) foot back towards the steam supply header causing any condensate in the line to drain to the header. Install a bypass trap in any low point to eliminate wet steam.

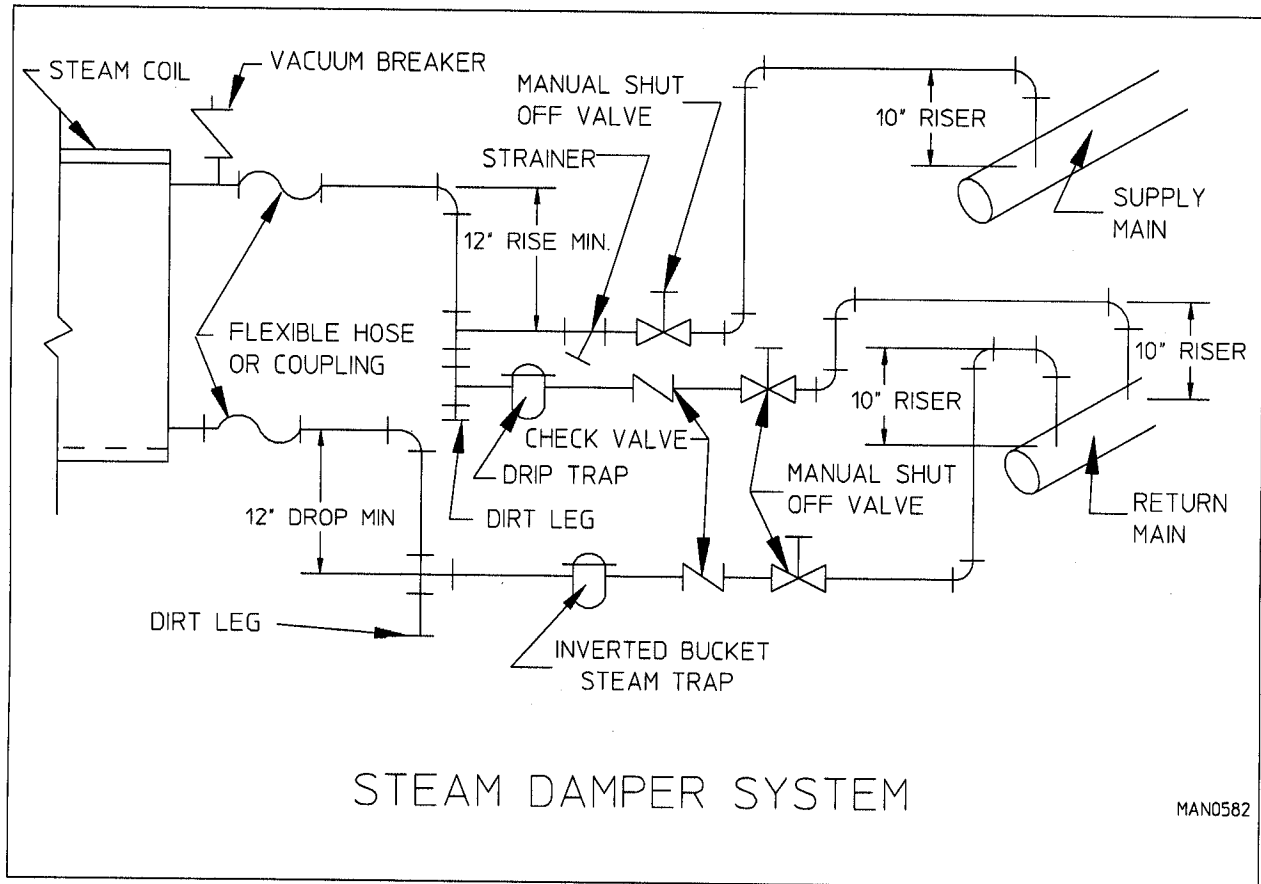

### 3. STEAM DAMPER AIR SYSTEM CONNECTIONS

#### A) AIR REQUIREMENTS

Compressed Air Supply	Air Pressure
Normal Supply	80 PSI
Minimum Supply	70 PSI
Maximum Supply	90 PSI

B) AIR CONNECTION

Air connection to system --- 1/8-inch N.P.T.

- C. No air regulation is provided with the dryer. External regulation of 80 psi **must be** provided. It is suggested that a regulator/filter gauge arrangement be added to the compressed air line just before the dryer connection. This is necessary to insure that correct and clean air pressure is achieved.

4. STEAM DAMPER SYSTEM

The ADS-100 dryer does not use an electric steam valve to control the dryers' temperature. On a call for heat, the steam dampers open allowing room air to be drawn through the steam coils, then into the basket (tumbler). Once the set point temperature has been reached, the steam dampers close and room air bypasses the steam coils and pass directly into the basket (tumbler).

The dampers are activated by an air operated piston/micro-valve arrangement which requires an uninterrupted 80 PSI (+/- 10 PSI) air supply. Therefore, if the air supply is interrupted, the dampers will close, thereby preventing heat from entering the basket (tumbler).

**NOTE:** Steam damper operation was tested and adjusted prior to shipping at 80 PSI.

**Proper trap selection is mandatory.** For ADS-100 dryers utilizing low pressure (15 psig or less), use an F & T (float and thermostatic) trap. For ADS-100 dryers utilizing high pressure (up to 125 psig), use an inverted bucket trap.

**IMPORTANT: DO NOT EXCEED 125 PSIG and DO NOT USE THERMODYNAMIC, DISC, OR IMPULSE TRAPS.**

Condensate disposal is important. **DO NOT** elevate the condensate return line after an F & T trap. Drain only by gravity into a properly vented low pressure return tank or condensate tank. A condensate line may be elevated after a bucket trap only if there is sufficient pressure to overcome the head. Determine steam pressure by deducting 12 PSI for the control valve, steam coils, and trap losses. Then, each foot of elevation will require 1/2 pound of remaining steam pressure.

**NOTE:** Flexible hose **must be** provided between the steam coils and main lines to prevent piping strains and/or cracks.

**NOTE:** **ALL** steam piping hook-up and maintenance **must be** performed by a qualified technician in accordance with local codes.

THE PRECEDING PRECAUTIONS ARE NECESSARY/MANDATORY and ANY VARIATION FROM THEM WILL VOID THE WARRANTY ON THE HEAT EXCHANGER.

## I. PREPARATION FOR OPERATION/START-UP

The following items **should be** checked before attempting to operate the dryer:

1. Read and follow all "CAUTION," "WARNING," and "DIRECTION" labels attached to the dryer.
2. Check incoming supply voltage to be sure that it is the same as indicated on the dryer data label affixed to the back of the dryer at the upper right hand corner (refer to **illustration in Section II, page 10**). In the case of 208 VAC or 230/240 VAC, the supply voltage **must match** the electric service exactly.
3. GAS MODELS - check to assure that the dryer is connected to the type of heat/gas indicated on the dryer data label.
4. GAS MODELS - the sail switch damper assembly was installed and preadjusted at the factory prior to shipping. However, each sail switch adjustment **must be** checked to assure that this important safety control is functioning.
5. Check to be sure drive belts between idler pulley and motor pulley have been reconnected.

**NOTE:** The drive belts were disconnected at factory prior to shipment.

6. GAS MODELS - be sure that **ALL** gas shut-off valves are in the open position.
7. Be sure all back panels (guards) and electric box covers have been replaced.
8. Check service door to assure that they are closed and secured in place.
9. Be sure the lint coop support bracket has been removed.
10. Be sure lint door is securely in place.

**NOTE:** Lint drawer **must be** all the way in place to activate safety switch otherwise the dryer will not start.

11. Rotate the basket (tumbler/drum) by hand to be sure it moves/rotates freely.
12. Check bolts, nuts, screws, terminals, and fittings for security.
13. STEAM MODELS - check to insure air supply (80 PSI) is on to the dryer.
14. STEAM MODELS - check to insure **ALL** steam shut-off valves are open.

## I. PREOPERATIONAL TESTS

All dryers are thoroughly tested and inspected before leaving the factory. However, a preoperational test **should be performed** before the dryer is publicly used. It is possible that adjustments have changed in transit or due to marginal location (installation) conditions.

1. Make sure main door is closed and lint door is securely in place.
2. Turn on electric power to the dryer.

A) To Start dryer:

1) Dual Timer Dryers...

- a) Turn the drying timer knob for a time of 20 minutes.
- b) Select "High-Temp."
- c) Push the "Push To Start" switch.

**NOTE:** The dryer can be stopped at any time by opening the main door. To restart the dryer, push the "Push To Start" switch.

2) Microprocessor Controller (computer) Dryers...

- a) L.E.D. display will read "FILL."

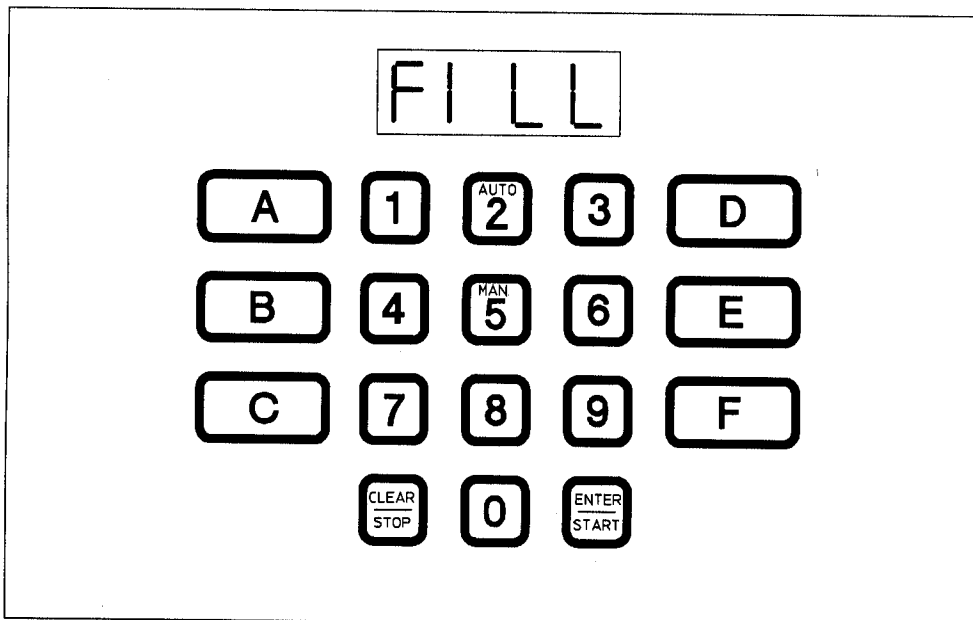

MAN0118



- b) Press the "E" (preprogrammed) cycle key on the touchpad of the keyboard assembly.
- c) The L.E.D. display will quickly read..."Ld30", "Lc04", and 'F180" (unless special programs were requested). These codes mean that the dryer is in the timed mode and will operate with heat of 180°F (fahrenheit) for 30 minutes drying time and have a 4 minute cool down period.
- d) The dryer will now start and the L.E.D. display will read "Dr30" (dry mode for 30 minutes) and count down in minutes.

**NOTE:** The dryer can be stopped at any time by opening the main door or by pressing the "CLEAR/STOP" key. To restart the dryer, press the "ENTER/START" key or preprogrammed cycle key (i.e., "E").

**NOTE:** Pressing keyboard (touchpad) key "A," "B," "C," "D," "E," and "F" will also start the dryer. The six (6) preprogrammed drying cycles ("A" through "F") have been stored in the microprocessor (computer's) memory. Refer to the microprocessor (computer) programming manual supplied with dryer for these preprogrammed cycles.

- 3. Check to insure that the basket (tumbler) starts in the clockwise (CW) direction. In addition, check the direction of the blower motor impellor (fan) to insure that impellor (fan) rotates in the clockwise (CW) direction as viewed from the front. If it is, the phasing is correct. If the phasing is incorrect, reverse two (2) of the leads at L1, L2, or L3 of the power supply connections made to the dryer.

**IMPORTANT:** Dryer blower motor impellor/fan as viewed from the front **must turn** in the clockwise (CW) direction, otherwise dryer efficiency will drastically be reduced and premature component failure can result.

#### 4. HEAT CIRCUIT OPERATIONAL TEST

##### A) GAS MODELS

- 1) When the dryer is first started (during initial start-up), the burner has a tendency not to ignite on the first attempt. This is because the gas supply piping is filled with air, so it may take a few minutes for this air to be purged from the lines.

**NOTE:** During the purging period, check to be sure that all gas shut-off valves are open.

- 2) The dryer is equipped with a Direct Spark Ignition (DSI) system which has internal diagnostics. If ignition is not established after the first attempt, the system will retry two (2) more times. If ignition is not established after three (3) attempts, the heat circuit in the DSI module will Lock-Out until it is manually reset.

**NOTE:** To reset the DSI system, open and close the main door and restart the dryer (press the "ENTER/START" key).

- 3) Once ignition is established, a gas pressure test **should be taken** at the gas valve pressure tap of each dryer to assure that the water column pressure is correct and consistent.

**NOTE:** Water column pressure requirements (measured at the gas valve pressure tap)...

NATURAL GAS ----- 3.5 - 4.0 INCHES W.C. (Water Column)  
 L.P. GAS ----- 10.5 - 11.0 INCHES W.C. (Water Column)

**IMPORTANT:** There is no regulator provided in an L.P. dryer. The water column pressure **must be regulated** at the source (L.P. tank) or an external regulator **must be added** to each dryer.

## B) ELECTRIC MODELS

- 1) Check the oven contactor(s) to insure that the electric oven is cycling properly.

## C) STEAM MODELS

- 1) ADS-100 dryers use a damper / shutter-controlled system. Check to insure that steam dampers are functioning properly.

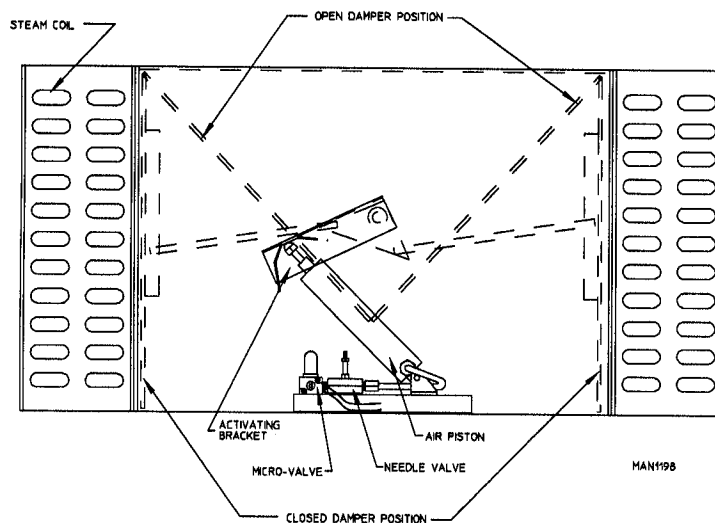

2) Check to insure that **ALL** of the steam plumbing is as specified in **Subsection H, page 32 and page 33**.

5. Make a complete operational check of **ALL** safety-related circuits...

Door Switch  
Hi-Limit Thermostat  
Cycling Thermostat  
Sail Switch (for GAS MODELS and ELECTRIC MODELS ONLY)

**NOTE:** To check for proper sail switch operation, open the main door and while holding main door switch plunger in, start dryer. The dryer should start but heat circuit **should not be** activated (on). If the heat (burner) does activate, shut dryer off and make necessary adjustments.

6. Make a complete operational check of **ALL** operating controls...

A) Dual Timer Dryers

Heat Timer  
Cool Down Timer  
Temperature Selection Switch

B) Microprocessor Controller (computer) Dryers

Preprogrammed cycles (keyboard/touchpad keys "A" through "F")  
"CLEAR/STOP" Key  
"ENTER/START" Key

7. A reversing basket (tumbler) dryer **should never** be operated with less than a 50 lb. load (dry weight). The size of the load will affect the coast-down and dwell (stop) times. The basket (tumbler) must come to a complete stop before starting in opposite direction. Spin times and stop times **are not** adjustable and have been preprogrammed into the microprocessor controller (computer) for a 120-second spin time and a 5-second dwell (stop) time.

**IMPORTANT:** The dryer basket (tumbler) is treated with a protective coating. **ADC** suggests tumbling old clothes or material in the basket (tumbler), using a mild detergent to remove the protective coating.

8. Each dryer **should be** operated through one complete cycle to assure that no further adjustments are necessary and that all components are functioning properly.

9. Microprocessor controller (computer) programs/selections...

- A) Each microprocessor controller (computer) has been preprogrammed by the factory with the most commonly used parameter (programs) selections. If microprocessor (computer) program changes are required, refer to the computer programming manual which was shipped with the dryer.

# SECTION IV

## DIRECT SPARK IGNITION (DSI) SYSTEM

### A. INTRODUCTION

The Direct Spark Ignition (DSI) System operates at 24 VAC and is a microprocessor based gas ignition control (DSI module) system which utilizes a line frequency spark as an ignition source. Safe proof of flame is accomplished through flame rectification.

The DSI module has a diagnostic L.E.D. (light emitting diode) indicating light which simplifies troubleshooting in the event of a fault.

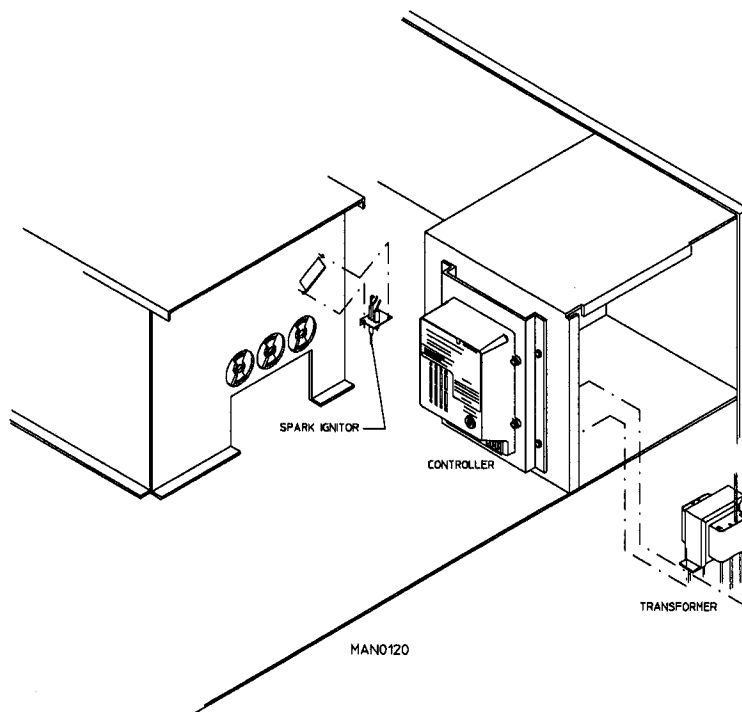

#### Other Features....

- Safe proof of ignition
- Multiple precise timing functions
- Draft tolerant burner supervision (recycles)
- Ignition retries
- Flame sensing via flame rectification
- AGA and CGA approved
- 24 VAC high cycle rated gas valves
- Suitable for operation with either natural gas or L.P. (liquid propane) gas
- Captive discharge spark
- Internal diagnostics

B. DSI SYSTEM (Flow Chart)

Direct Spark Ignition (DSI) Operation Flow Chart

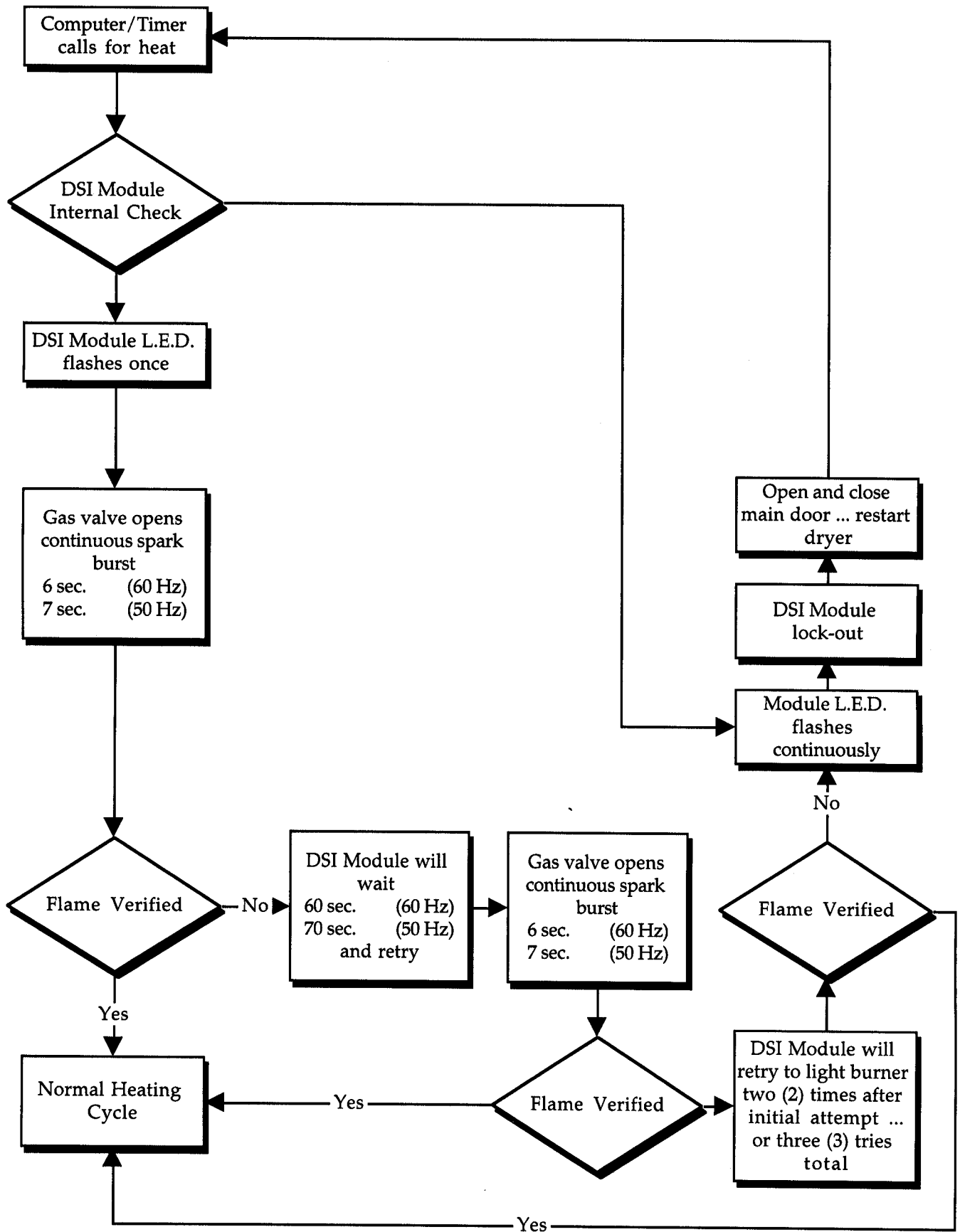

## C. GENERAL SYSTEM INFORMATION

### 1. DIRECT SPARK IGNITION (DSI) TERMS (definitions):

- A) DSI MODULE RED L.E.D. INDICATOR LIGHT - this light is located on the upper right side corner of the DSI module. This diagnostic indicator simplifies the operational and troubleshooting procedures of the system.
- B) LOCK-UP MODE - DSI module red L.E.D. indicator light stays on continuously. This indicates there is a system fault and most likely the fault is the DSI module itself.
- C) LOCK-OUT MODE - DSI module red L.E.D. indicator light will flash on and off continuously. This indicates a system fault exists (no ignition after the initial spark burst plus two (2) retry attempts or ignition was started but lost and not maintained). Normally not the fault of the DSI module itself, but some other external component (i.e., ignitor assembly, air turbulence, etc...).
- D) RETRY - no flame has been sensed; retry for ignition (after initial attempt) will be two (2) more times.
- E) FLAME-OUT - burner flame shut down by the DSI module due to lack of flame verification. This condition occurs only after ignition has been evident but is lost. System will immediately attempt to relight the burner. If after four (4) recycles (attempts) flame is not established, system will go into the Lock-Out Mode.
- F) RECYCLE - flame has been sensed but lost. Initiate new ignition sequence (four [4] cycles permitted).

### 2. DIRECT SPARK IGNITION (DSI) SYSTEM COMPONENTS/FUNCTIONS:

- A) The DSI MODULE is designed to be the "controller" of the DSI System. When activated by the dryers controls, this module constantly monitors and controls the functions of the DSI system (i.e., spark activation, gas valve on/off functions, and flame verification etc.), can be operated at either 50 Hz or 60 Hz; and has self diagnostic capabilities.

The L.E.D. (red indicator light) on the DSI module simplifies the troubleshooting procedure in the event of a fault within the DSI system. If the L.E.D. on the module is on continuously (Lock-Up Mode), the fault is likely to be internal to the module. A flashing L.E.D. (Lock-Out Mode) indicates the problem or fault is most likely external to the DSI modmodule.

The DSI module allows for a continuous spark burst of six (6) seconds duration (for 60 Hz) and seven (7) seconds (for 50 Hz) between retries (prior to the next ignition attempt).

If a flame is not established after the initial six (6) second spark burst, the module will allow for an additional two (2) retry attempts, after which the module will go into the Lock-Out Mode.

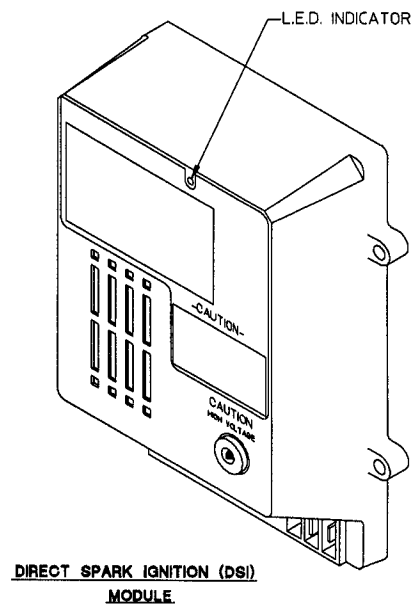

**NOTE:** To reset the DSI module if it is in the Lock-Out Mode, open and close the main door then restart the dryer.

The module also provides for **Safe Proof of Ignition**. If a flame is not sensed by the flame probe electrode (of the ignitor/flame-probe assembly) within a specified time frame, the module will de-energize the gas valve and the ignitor/flame-probe assembly, and go into the Lock-Out Mode.

To prevent excessive wear on the gas valve, if a flame is established (sensed) but then lost (flame out due to possible air turbulence), the DSI module will de-energize the gas valve and immediately restart the ignition sequence. The module will allow for four (4) retry attempts, after which the module will go into the Lock-Out Mode.

**NOTE:** To reset the DSI module if it is in the Lock-Out Mode, open and close the main door then restart the dryer.

**WARNING:** THE DSI MODULE IS NOT FIELD REPAIRABLE.

**IMPORTANT:** The DSI module is a precision instrument and should be handled carefully. Rough handling or distorting components could cause the module to malfunction.

- B) The 24 VAC TRANSFORMER is designed to step down the operating (primary) voltage of the dryer from 120, 208, or 240 VAC to the 24 VAC (secondary voltage) which is necessary to operate the DSI system and in some cases the controls of the dryer.

This transformer has multi-primary taps which allows for one (1) transformer to be used for any voltage application including...120, 208, or 240 volts. (Refer to **Subsection 6, page 53 and page 54** for specific transformer/wiring termination information.)

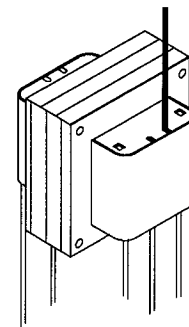

**24 VAC TRANSFORMER**

- C) The IGNITOR/FLAME-PROBE ASSEMBLY is located in the burner flame area and is used to ignite the gas by the use of a high (25,000) voltage synchronous spark, and to provide feedback information to the DSI module as to whether the burner flame is on.

The ignitor/flame-probe assembly consists of a ceramic insulated ignitor electrode, a ground rod and a ceramic insulated flame probe electrode. The GAP between the ignitor (spark) electrode and the ground rod is set, and **must be maintained at 1/8" +/- 1/32"** (.1250 +/- .0312).

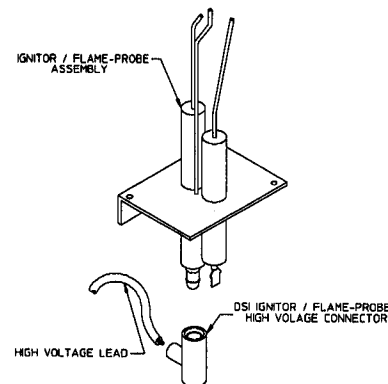



When the DSI module provides the high voltage synchronous spark (25,000 volts) through the high voltage (HV) wire/lead, a spark is produced "over" the GAP. When this spark is produced, the gas valve is opened. Upon ignition, the resistance in the flame probe electrode (of the ignitor flame-probe assembly) changes and the information is sent to the DSI module via the sensor probe lead connection to the module. Once the resistance is changed and sensed, the DSI module will sustain the gas flow (provide 24 VAC power to the gas valve).

**| IMPORTANT: The gap setting on the ignitor flame-probe assembly is critical.**

- D) The DSI 24 VAC GAS VALVE used is the redundant type which means the gas valve is actually two (2) gas valves in one; one in series with the other. This is a safety feature which provides protection against gas flow in the event of a failure of one of the valves to seat properly. Other features are that the valve has a manual shut off, a pressure tap outlet, and is designed for easy conversion to regulated L.P. gas.

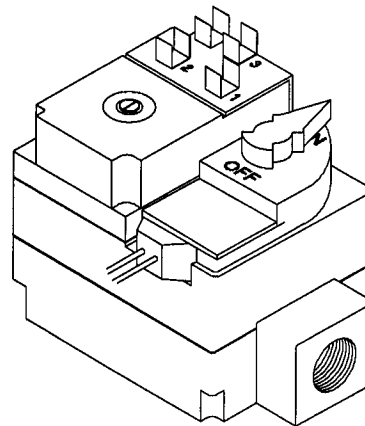

**| IMPORTANT: The DSI gas valve is not field repairable. There are no parts available for field repair.**

P/N - 128928 36C REDUNDANT VALVE

## D. NORMAL SYSTEM OPERATION (summary)

On a call for heat by the dryers controls, the DSI module is energized (module red L.E.D. will flash on for approximately one [1] second) confirming that the dryers controls (heat circuits) are operating properly and that the DSI system has been activated.

**| NOTE: If the module's red L.E.D. light stays on continuously (Lock-Up Mode), this indicates that there is a fault in the system...most likely the DSI module itself.**

Immediately, the gas valve will be energized and a continuous spark burst will be evident (on) at the burner ignitor-probe assembly. This continuous spark burst will last six (6) seconds for 60 Hz applications or seven (7) seconds for 50 Hz applications. The burner flame should now be established (verified).

If at this time the flame has not been established/verified, the DSI module will de-energize the gas valve and flame probe assembly than wait for a period of sixty (60) seconds (for 60 Hz application) or seventy (70) seconds (for 50 Hz application) before attempting another spark burst retry. The DSI module will try a total of three (3) times (initial attempt and two [2] retries) to light the burner. If the burner flame is not

established after the third attempt, the DSI module will LOCK-OUT and the module's diagnostic red L.E.D. indicator will flash on and off continuously indicating that there is a malfunction. To reset or cancel the LOCK-OUT condition, open and close main door and restart dryer.

If burner flame is established/verified, the DSI and burner system will continue through a normal heating cycle where the DSI system and burner will cycle on and off as required by the dryers controls.

During a normal heating cycle, should a FLAME-OUT occur (i.e., severe air turbulence forces the flame away from the ignitor assembly flame probe), the DSI module will shut the valve off and immediately try to re-establish the burner flame. The DSI module will "recycle" (try) a total of four (4) times. If the flame is not re-established by the fifth attempt (recycle) the DSI module will LOCK OUT and the DSI module's diagnostic red L.E.D. indicator will flash on and off continuously indicating that there is a malfunction. To reset or cancel the LOCK-OUT condition, open and close main door and restart dryer.

## E. SYSTEM DIAGNOSIS

When the dryer calls for heat, 24 VAC from the DSI transformer is applied to the "TH" and "GND" terminals of the DSI module. The L.E.D. (red indicator light) will flash once (for approximately one [1] second), the gas valve will be energized, and a continuous spark burst of six (6) seconds duration (for 60 Hz applications) and of seven (7) seconds duration (for 50 Hz applications) is produced at the tip of the ignitor electrode/grounding rod of the ignitor/flame-probe assembly. If a flame is not sensed by the flame probe electrode (of the ignitor/flame-probe assembly after the initial six (6) second burst, the DSI module will de-energize the gas valve and the ignitor/flame-probe assembly then wait for a period of sixty (60) seconds (for 60 Hz application) and seventy (70) seconds (for 50 Hz applications) before attempting another spark burst (retry). The DSI module will attempt a total of two (2) additional retries. If a flame cannot be established after these additional retry attempts, the DSI module will go into the Lock-Out Mode (the L.E.D. will FLASH CONTINUOUSLY).

**NOTE:** To reset the DSI module if it is in the Lock-Out Mode, open and close the main door, then restart the dryer.

If a flame has been established then lost, the DSI module will go into the Lock-Out Mode. This Lock-Out Mode will de-energize the gas valve, the ignitor/flame-probe assembly, and simultaneously the L.E.D. (red indicator light) on the DSI module will FLASH CONTINUOUSLY. This continuously flashing L.E.D. display will indicate some sort of ignition abnormality.

**NOTE:** To reset the DSI module if it is in the Lock-Out Mode, open and close the main door, then restart the dryer.

### 1. GAS PRESSURE

A gas pressure test **should be** taken at the gas valve pressure tap provided on the valve to assure that the Water Column (W.C.) pressure is correct and consistent.

There are two (2) types of devices commonly used to measure water column (W.C.) pressure, they are the spring/mechanical type gauge and the water column test gauge (manometers). The use of the spring/mechanical type of gauges is **NOT RECOMMENDED** because it/they are very easily damaged and they are not always accurate. The preferred type of gauge is the manometer because it is a simple device to use and is highly accurate. A manometer is simply a glass or transparent plastic tube with a scale graduated in inches. When it is filled with water and pressure is applied, the water in the tube rises, showing the exact water column (W.C.) pressure.

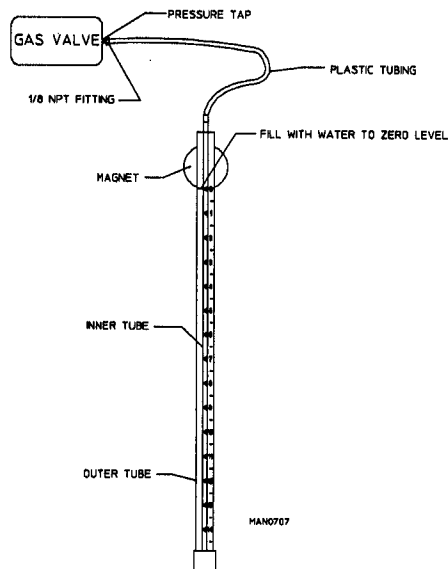

**WARNING:** Test all connections for leaks by brushing on a soapy water solution. **NEVER TEST FOR LEAKS WITH A FLAME.**

- A) Connect water column test gauge (manometer) to the gas valve pressure tap (1/8" N.P.T.).
- B) Start the dryer. With the burner on, the correct water column (W.C.) reading in inches should be:
  - Natural Gas ..... 3.5 - 4.0 inches W.C.
  - L.P. (liquefied propane) Gas ..... 10.5 - 11.0 inches W.C.

When a gas dryer is first started (during the initial time of installation/start-up), it has a tendency not to ignite on the first ignition attempt. This is due to the fact that the gas supply piping is filled with air, so it may take a few minutes for the air to be purged from the supply line(s). During this purge period there may be insufficient gas pressure for ignition, which might cause the DSI module to go into the Lock-Out Mode (the L.E.D. will FLASH CONTINUOUSLY).

**NOTE:** To reset the DSI module if it is in the Lock-Out Mode, open and close the main door, then restart the dryer.

**NOTE:** During the purge period, check to be sure that **ALL** gas shut-off valves are open.

## 2. IGNITOR/FLAME-PROBE ASSEMBLY

The ignitor/flame-probe assembly consist of of a ceramic insulated ignitor electrode, a ground rod, and a ceramic insulated flame-probe electrode. The GAP between the ignitor electrode and ground rod is set, and **must be** maintained at 1/8" +/- 1/32" (.1250 +/- .0312). When the DSI module provides the high voltage synchronous spark (25,000 volts) through the high voltage (HV) lead, a spark is produced "over" the GAP. When this spark is produced, the gas valve is opened. Upon ignition, the resistance in the flame-probe electrode (of the ignitor/flame-probe assembly) changes. Once the resistance is changed, it initializes the DSI module to sustain the gas flow (from the gas valve).

**IMPORTANT: The gap setting on the ignitor/flame-probe assembly is critical.**

A) The GAP on the ignitor/flame-probe assembly **must** be set, and held at  $1/8" \pm 1/32"$  (.1250  $\pm$  .0312). If this  $1/8"$  GAP is not maintained (if the GAP is either too large or too small), the DSI module will indicate a system malfunction and go into the Lock-Up Mode (the L.E.D. will FLASH CONTINUOUSLY).

1) To check and/or set the required  $1/8"$  GAP, use the DSI Gap Feeler Gauge (ADC P/N 305410) or similar type of device to determine the GAP size. **DO NOT USE FEELER GAUGE TO SET THE GAP**, use it to determine the size of the gap ONLY. If an adjustment is necessary, bend the ground rod to achieve the correct gap, then recheck the  $1/8"$  GAP with a feeler gauge.

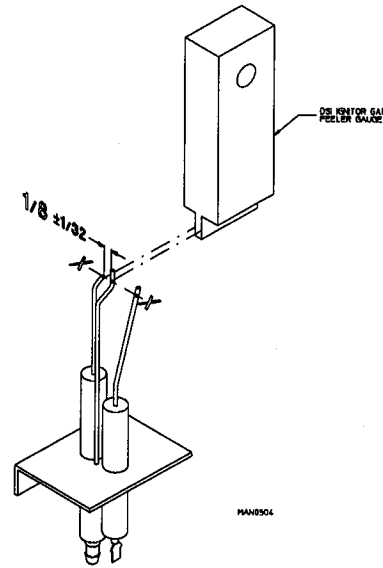

**NOTE:** To reset the DSI module if it is in the Lock-Up Mode, interrupt then re-establish power to the dryer, then make a selection to restart the dryer.

B) The ALIGNMENT of the ignitor/flame-probe assembly in relation to the GAP on the ignitor electrode/ground rod **must** be maintained in as vertical a (straight line) position as possible (refer to the illustration below), otherwise, the DSI module will indicate a system malfunction and go into the Lock-Out Mode (the L.E.D. will FLASH CONTINUOUSLY).

C) The POSITIONING of the ignitor/flame-probe assembly is extremely important because it provides the necessary feedback information to the DSI module. The flame-probe electrode **must** be POSITIONED  $1/4"$  minimum into the flame path (refer to the illustration below) and one (1) inch maximum from the burner, otherwise, the DSI module will indicate a system malfunction and go into the Lock-Out Mode (the L.E.D. will FLASH CONTINUOUSLY).

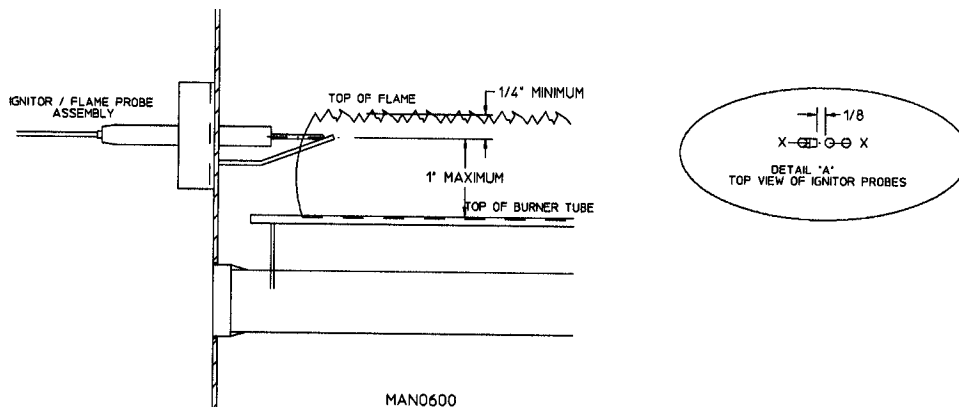

**NOTE:** To reset the DSI module if it is in the Lock-Out Mode, open and close the main door, then restart the dryer.

AMERICAN DRYER CORP.

FALL RIVER, MA.

ABBREVIATIONS: MC-MICRO COMP SI-SPARK IGNT.

561782

GAS DRYER 208-240V. 50/60 Hz. 3Ø 3 WIRE. 100# REV.

ASB-ARC SUP. BOARD, H.L.S.-HIGH LIMIT SWITCH  
S.S.-SAL SWITCH, T.S.-TEMP SENSOR, RB-RELAY BOARD

DATE: 9/11/87

REV.	DESCRIPTION	DATE	BY
1	SIS. MC HWIRE MOD.	11/87	C.S. PCB

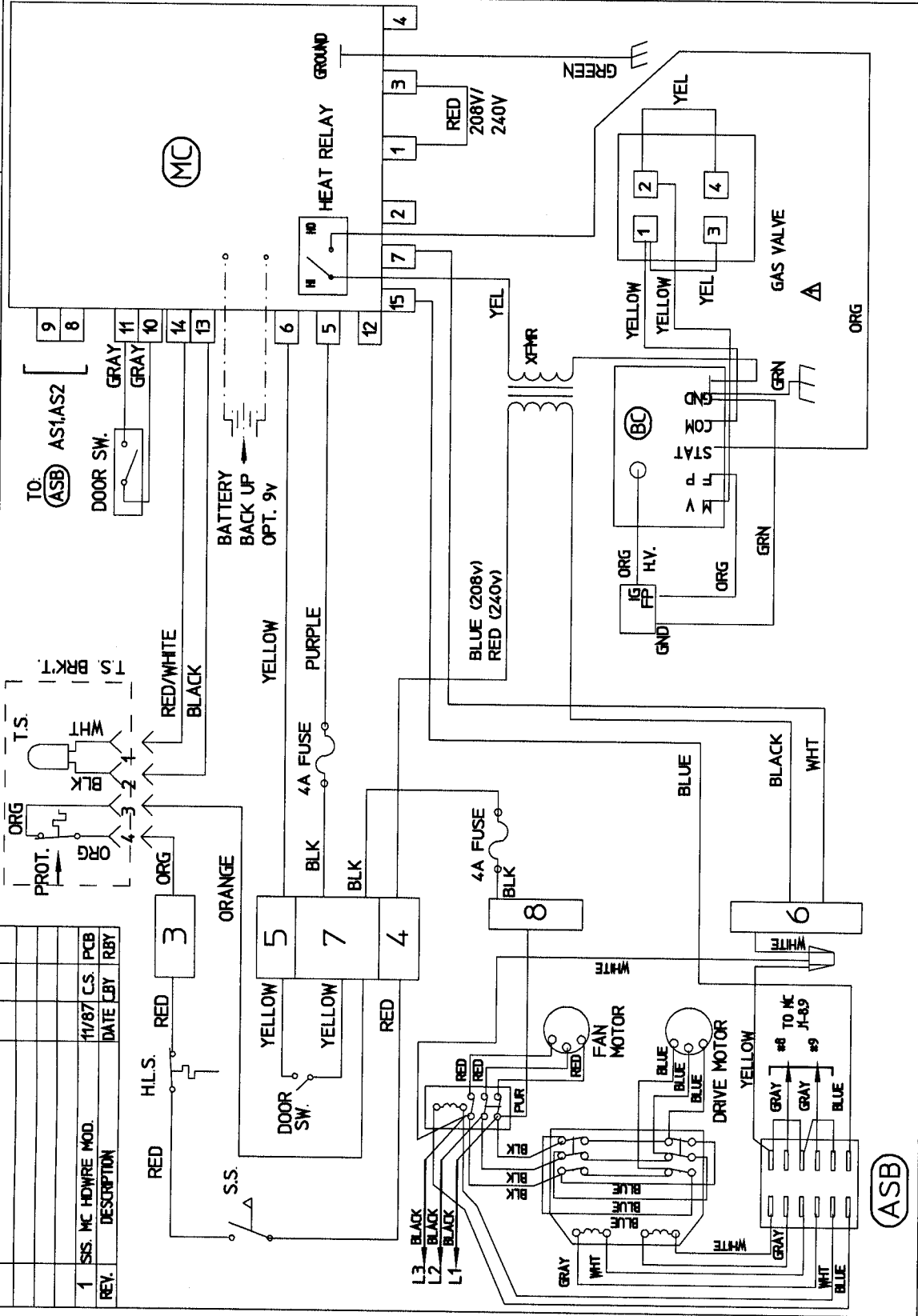

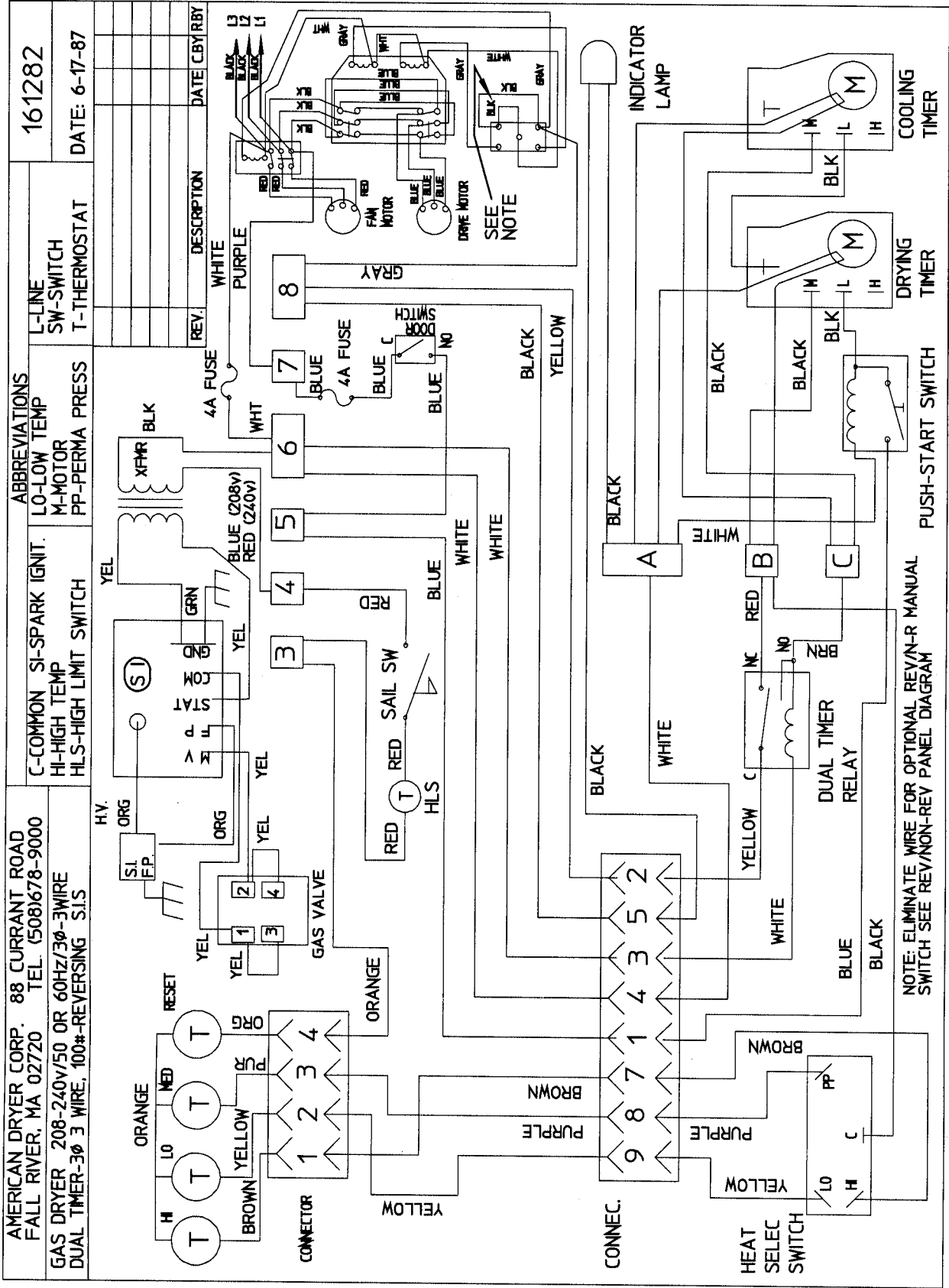

### 3. AIR TURBULENCE

If there is sail switch flutter due to air turbulence or improper impellor rotation and/or a restriction in the exhaust duct work, the DSI module will cycle erratically. This in turn might cause the DSI module into either a LOCK-OUT condition (where the L.E.D. will FLASH CONTINUOUSLY) or a LOCK-UP condition (where the L.E.D. will DISPLAY CONTINUOUSLY).

A) If air turbulence causes the flame to move away from the flame probe electrode (of the ignitor/ flame-probe assembly), or if the flame goes out completely during the heat (flame) cycle, the DSI module will attempt to re-establish a flame by going into a **reignition cycle**

1) This **reignition cycle** allows for a TOTAL of four (4) consecutive reignition attempts. If a flame **cannot** be re-established within this time frame, on the fifth consecutive re-ignition attempt, the DSI module will go into the Lock-Out Mode (the L.E.D. will FLASH CONTINUOUSLY).

**NOTE:** To reset the DSI module if it is in the Lock-Out Mode, open and close the main door, then restart the dryer.

**NOTE:** To reset the DSI module if it is in the Lock-Up Mode, interrupt then re-establish power to the dryer, then make a selection to restart the dryer.

### 4. DIRECT SPARK IGNITION (DSI) MODULE

If there is some sort of operational interference in the DSI system, the DSI module (acting as the "controller" for the system) will either go into a Lock-Out Mode (where the L.E.D. will FLASH CONTINUOUSLY) or into a Lock-Up Mode (where the L.E.D. will DISPLAY CONTINUOUSLY).

A) Operational interference is any adverse condition (whether internal or external) to the system. (Electrical noise is considered external noise interference because it can cause the DSI module to cycle erratically.)

**NOTE:** To reset the DSI module if it is the Lock-Out Mode, open and close the main door, then restart the dryer.

If the Gap, the Alignment, and the Position of the ignitor/flame-probe assembly are correct if the gas flow/pressure is constant and consistent: if there is no adverse air turbulence; and if the DSI module remains in in the Lock-Up Mode (the L.E.D. will DISPLAY CONTINUOUSLY); then, there is a malfunction within the DSI module itself, and it **must be** replaced.

## 5. WIRING

If the DSI module is in the Lock-Out Mode (where the L.E.D. will FLASH CONTINUOUSLY), and the mechanical components have been checked (i.e., the ignitor/flame-probe assembly, the gas valve, etc.), then they may be somewhere in the DSI system wiring.

- A) Check all wiring within the DSI system, especially the ground connections on the DSI module and the ignitor/flame-probe assembly.

**NOTE:** Check for any possible damage to the ceramic insulators on the ignitor electrode and the flame-probe electrode of the ignitor/flame-probe assembly.

- B) Make sure the flame-probe electrode of the ignitor/flame-probe assembly is positioned no more than one (1) inch maximum from the burner tube (refer to the **bottom illustration on page 49.**)

**CAUTION: DO NOT LET THE IGNITOR/FLAME-PROBE ASSEMBLY TOUCH THE BURNER TUBES; OTHERWISE, THE ENTIRE ASSEMBLY WILL SHORT OUT.**

## 6. DSI 24 VAC TRANSFORMER

The DSI transformer is designed to step down the operating voltage of the dryer to 24 VAC to operate the DSI module. This transformer, like all transformers, is two (2) sided (refer to the **illustrations on page 45 and page 54.**)

- A) Primary Side:

This is the incoming voltage side - 120 VAC, 208 VAC, 240 VAC - of the transformer.

- B) Secondary Side:

This is the step down side - 24 VAC - of the transformer.

**WARNING: 208 VAC and 230/240 VAC ARE NOT THE SAME.** All voltage connections **should** be checked and confirmed according to the wiring diagram provided with the individual dryer. Any damage done to dryer components due to improper voltage connections will automatically VOID THE WARRANTY.



**IMPORTANT:** The ADC Service Department **must be** contacted prior to any wiring change and/or conversion because, depending on the change/conversion required, some parts may have to be added, deleted, or changed. When contacting the ADC Service Department, they **must be** given the correct model number(s) and serial number(s) for the dryer(s).

**NOTE:** Any wiring change(s) and/or conversion(s) **should be** accomplished by a QUALIFIED ELECTRICAL TECHNICIAN.

### 1) TRANSFORMER WIRING

There are six (6) color-coded wires coming from the 24 VAC transformer. There are four (4) wires coming from the primary incoming) voltage side of the transformer. Their application and color-coding are as follows:

- a) For 120 VAC application ONLY;
  - (1) The BLACK and WHITE wires are used
  - (2) The Red and Blue wires are capped off individually.
  
- b) For 208 VAC application ONLY;
  - (1) The BLACK and BLUE wires are used.
  - (2) The Red and White wires are capped off individually.
  
- c) For 240 VAC application ONLY;
  - (1) The BLACK and RED wires are used.
  - (2) The Blue and White wires are capped off individually.

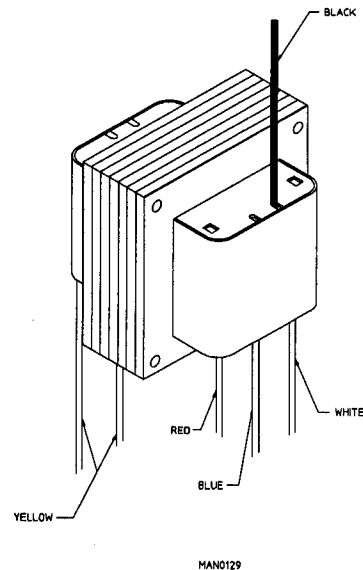

There are two (2) yellow wires coming from the secondary (step down) side of the transformer.

- d) One (1) YELLOW wire is connected to the GND (ground) terminal on the DSI module.
  
- e) One (1) YELLOW wire is connected to:
  - (1) The HI (Heat In) terminal of the microprocessor, then from the HO (Heat Out) of the microprocessor to the TH (Thermostat Heat Input) terminal of the DSI module (if the dryer is built with the microprocessor option).
  
  - (2) The TH (Thermostat Heat Input) terminal of the DSI module if the dryer is built with the dual timer option.

# SECTION V

## SERVICE/PARTS INFORMATION

### A. SERVICE

1. Service **must be** performed by a qualified trained technician, service agency, or gas supplier. If service is required, contact the distributor from whom the ADC equipment was purchased. If the distributor cannot be contacted or is unknown, contact the ADC Service Department for a distributor in your area.

**NOTE:** When contacting the ADC Service Department, be sure to give them the correct **model number** and **serial number** so that your inquiry is handled in an expeditious manner.

### B. PARTS

1. Replacement parts **should be** purchased from the distributor from whom the ADC equipment was purchased. If the distributor cannot be contacted or is unknown, contact the ADC Parts Department for a distributor in your area. Parts may also be purchased directly from the factory by calling the ADC Parts Department at (508) 678-9010.

**NOTE:** When ordering replacement parts from the ADC dealer or ADC factory, be sure to give them the correct **model number** and **serial number** so that your parts order can be processed in an expeditious manner.

# SECTION VI

## WARRANTY INFORMATION

### A. RETURNING WARRANTY CARD(S)

1. Before any dryer leaves the ADC factory test area, a warranty card (ADC P/N 112250) is affixed to the glass of the main door. These warranty cards are intended to serve the customer in two ways. First, when ADC receives the warranty card(s) back from a customer, we mail the appropriate parts manual (at no charge), to the address indicated on the returned card. Second, we record the individual installation date and warranty information to better serve you should you file a warranty claim.

A) If a warranty card did not come with your dryer, contact the ADC Warranty Department or the ADC Service Department at (508) 678-9000.

### B. WARRANTY

For a copy of the ADC commercial warranty covering your particular dryer(s), contact the ADC distributor from whom you purchased the equipment and request a dryer warranty form. If the distributor cannot be contacted or is unknown, warranty information can be obtained from the factory by contacting the ADC Warranty Department at (508) 678-9000.

**NOTE:** Whenever contacting the ADC factory for warranty information, be sure to have the dryer(s) **model number** and **serial number** available so that your inquiry can be handled in an expeditious manner.

### C. RETURNING WARRANTY PART(S)

All dryer or parts warranty claims and/or inquires **should be** addressed to the ADC Warranty Parts Department. To expedite processing, the following procedures **must be** followed:

1. No parts are to be returned to ADC without prior written authorization (Return Material Authorization) from the factory.

**NOTE:** An R.M.A. ("Return Material Authorization") is valid for only sixty (60) days from date of issue.

A) The R.M.A. issued by the factory, as well as any other correspondence pertaining to the returned part(s) **must be** included inside the package with the failed merchandise.

2. Each part **must be** tagged with the following information...

A) **Model number** and **serial number** of the dryer from which part was removed.

B) Nature of failure (be specific).

C) Date of dryer installation.

D) Date of part failure.

E) Specify whether the part(s) being returned is for a replacement, a credit, or a refund.

**NOTE:** If a part is marked for a credit or a refund, the invoice number covering the purchase of the replacement part **must be** provided.

**NOTE:** Warranty tags (ADC P/N 450064) are available at **no charge** from ADC upon request.

3. The company returning the part(s) must clearly note the complete company name and address on the outside of the package.

4. **ALL** returns **must be** properly packaged to insure that they are not damaged in transit. Damage claims are the responsibility of the shipper.

**IMPORTANT:** **NO** replacements, credits, or refunds will be issued for merchandise damaged in transit.

5. All returns **should be** shipped to the ADC factory in such a manner that they are insured and a proof of delivery can be obtained by the sender.

6. **Shipping charges are not** the responsibility of ADC. All returns **should be** "prepaid" to the factory. Any "C.O.D." or "COLLECT" returns **will not be accepted**.

**IMPORTANT:** **NO** replacements, credits, or refunds will be issued if the claim cannot be processed due to insufficient information. The party filing the claim will be notified in writing, either by "FAX" or "CERTIFIED MAIL - Return Receipt Requested," as to the information necessary to process the claim. If a reply is **not** received by the ADC Warranty Department within thirty (30) days from the FAX/letter date, then no replacement, credit, or refund will be issued and the **merchandise will be discarded**.

# SECTION VII

## ROUTINE MAINTENANCE

### A. CLEANING

A program and/or schedule **should be** established for periodic inspection, cleaning and removal of lint from various areas of the dryer, as well as throughout the duct work system. The frequency of cleaning can best be determined from experience at each location. Maximum operating efficiency is dependent upon proper air circulation. The accumulation of lint can restrict this air flow. If the guidelines in this section are met, an ADC dryer will provide many years of efficient, trouble-free, and - most importantly - safe operation.

**WARNING: LINT FROM MOST FABRICS IS HIGHLY COMBUSTIBLE. THE ACCUMULATION OF LINT CAN CREATE A POTENTIAL FIRE HAZARD.**

**WARNING: KEEP DRYER AREA CLEAR AND FREE FROM COMBUSTIBLE MATERIALS, GASOLINE AND OTHER FLAMMABLE VAPORS AND LIQUIDS.**

**NOTE:** Suggested time intervals shown are for average usage which is considered six (6) to eight (8) operational (running) hours per day.

#### *DAILY (beginning of each work shift)*

Clean lint from lint screen. Inspect lint screen and replace if torn.

#### *WEEKLY*

Clean lint accumulation from lint chamber, thermostat, and microprocessor temperature sensor (sensor bracket) area.

**WARNING: TO AVOID THE HAZARD OF ELECTRICAL SHOCK, DISCONTINUE ELECTRICAL SUPPLY TO THE DRYER.**

#### *STEAM DRYERS*

Clean steam coil fins. Suggest using compressed air and a vacuum cleaner with brush attachment.

**NOTE:** When cleaning steam coil fins, be careful not to bend the fins. If fins are bent, straighten by using fin comb which is available from local air conditioning supply houses

### **90 DAYS**

Remove lint from around basket (tumbler), drive motors, and surrounding areas. Remove lint from gas valve burner area with a dusting brush or vacuum cleaner attachment.

**NOTE:** To prevent damage, avoid cleaning and/or touching the ignitor/ flame-probe assembly.

Remove lint accumulation from inside control box and at rear area behind control box.

### **6 MONTHS**

Inspect and remove lint accumulation in customer furnished exhaust duct work system and from dryers internal exhaust ducting.

**WARNING: THE ACCUMULATION OF LINT IN THE EXHAUST DUCT WORK CAN CREATE A POTENTIAL FIRE HAZARD.**

**WARNING: DO NOT OBSTRUCT THE FLOW OF COMBUSTION AND VENTILATION AIR. CHECK CUSTOMER FURNISHED BACK DRAFT DAMPERS IN EXHAUST DUCT WORK. INSPECT and REMOVE ANY LINT ACCUMULATION WHICH CAN CAUSE THE DAMPER TO BIND OR STICK.**

**NOTE:** A back draft damper that is sticking partially closed can result in slow drying and shutdown of the heat circuit safety switches or thermostats.

**NOTE:** When cleaning dryer cabinet(s), avoid using harsh abrasives. A product intended for the cleaning of appliances is recommended.

## **B. ADJUSTMENTS**

*7 Days After Installation and Every 6 Months Thereafter*

Inspect bolts, nuts, screws (bearing set screws), non-permanent gas connections (unions, shut-off valves, orifices, and grounding connections). Motor and drive belts **should be** examined. Cracked or seriously frayed belts **should be** replaced. Tighten loose V-belts when necessary. Make a complete operational check of controls and valves. Make a complete operational check of all safety devices (door switch, sail switch, burner and hi-limit thermostats).

### C. LUBRICATION

The motor bearings, idler bearings, and basket (tumbler) bearings are permanently lubricated. **NO LUBRICATION IS NECESSARY.**

# SECTION VIII

## TROUBLESHOOTING

The information provided will help isolate the most probable component(s) associated with the difficulty described. The experienced technician realizes, however, that a loose connection or broken/shorted wire may be at fault where electrical components are concerned...not necessarily the suspected component itself. Electrical parts **should always be checked for failure before being returned to the factory.**

**WARNING: ALL SERVICE and TROUBLESHOOTING SHOULD BE PERFORMED BY A QUALIFIED PROFESSIONAL OR SERVICE AGENCY.**

**WARNING: WHILE MAKING REPAIRS, OBSERVE ALL SAFETY PRECAUTIONS DISPLAYED ON THE DRYER OR SPECIFIED IN THIS MANUAL.**

**IMPORTANT:** When replacing blown fuses, the replacement must be of the exact rating as the fuse being replaced. The information provided **should not** be misconstrued as a handbook for use by an untrained person in making repairs.

### Microprocessor (Computer) Models

#### **A. No L.E.D. display**

1. Service panel fuse blown or tripped circuit breaker
2. Arc suppressor (A.S.) F1 (4-amp) fuse blown
3. Failed microprocessor controller (computer)
4. Failed arc suppressor (A.S.) board

#### **B. Drive motor not operating (does not start)**

1. Failed drive motor contactor (relay)
2. Failed arc suppressor (A.S.) board
3. Failed drive motor
4. Failed microprocessor controller (computer)



**C. Reversing drive motor operates in one direction only...stops and restarts in same direction (reversing models only)**

1. Blown fuse (if applicable)
2. Failed reversing contactor (relay)
3. Failed arc suppressor (A.S.) board
4. Failed microprocessor controller (computer)

**D. Drive motor operates okay for a few minutes, and then stops and will not restart**

1. Motor is overheating and tripping out on internal overload protector
  - a. Motor air vents clogged with lint
  - b. Low voltage to motor
  - c. Failed motor
  - d. Basket (tumbler) is binding...check for an obstruction
  - e. Failed idler or tumbler bearings

**E. Blower motor not operating (does not start)**

1. Blown FU3 fuse (if applicable)
2. Failed blower motor contactor (relay)
3. Failed arc suppressor (A.S.) board
4. Failed motor
5. Failed microprocessor controller (computer)

**F. Blower motor operates okay for a few minutes, and then stops and will not restart**

1. Motor is overheating and tripping out on internal overload protector
  - a. Motor air vent is clogged with lint
  - b. Low voltage to motor
  - c. Failed motor
  - d. Failed (out of balance) impellor (fan)
  - e. V-belt(s) are too tight

**G. Both drive motor and blower motor not operating (do not start)...microprocessor (computer) motor indicator dots are on**

1. Fault in A.C. main door switch circuit
2. Failed arc suppressor (A.S.) board
3. Failed microprocessor controller (computer)
4. Failed 24 VAC transformer

**H. Both drive motor and blower motor run a few minutes and stop...microprocessor controller (computer) L.E.D. display continues to read time or percent of extraction and all indicator dots are off**

1. Fault in D.C. main door switch circuit
  - a. Failed main door switch
  - b. Main door switch out of adjustment
  - c. Loose connection in D.C. door switch circuit

**I. No heat...**

**GAS MODELS ONLY**

1. Fault in sail switch circuit
  - a. Sail switch out of adjustment and/or faulty (failed)
  - b. Sail switch not closing or fluttering
    - 1) Check blower (impellor/fan) motor and rotation direction
    - 2) Restriction in location exhaust system
2. Failed burner hi-limit
3. Failed lint compartment automatic (225°) safety thermostat
4. Arc suppressor (A.S.) board F2 (4-amp) fuse blown
5. Failed microprocessor controller (computer)

**...Ignitor sparks, burner goes on and off right away**

1. DSI ignitor/ flame-probe out of adjustment...reposition closer to the flame area

2. Sail switch not closing or fluttering
  - a. Lint screen is dirty
  - b. Restriction in exhaust duct work
3. Insufficient make-up air
4. Failed ignitor/flame-probe assembly
5. Failed DSI module
6. Failed gas valve

### **ELECTRIC MODELS ONLY**

1. Fault in sail switch circuit
  - a. Sail switch out of adjustment and/or faulty (failed)
  - b. Sail switch not closing or fluttering
    - 1) Check blower (impellor/fan) motor and rotation direction
    - 2) Restriction in location exhaust system
2. Failed oven hi-limit
3. Failed lint compartment automatic (225°) safety thermostat
4. Failed oven contactor (relay)
5. Failed microprocessor controller (computer)

### **STEAM MODELS ONLY**

1. Steam dampers binding and/or stuck in the closed position
2. Failed lint compartment automatic (225°) safety thermostat
3. Fault in lint chamber sensor bracket hi-heat (limit) protector thermostat
4. Arc suppressor (A.S.) board F2 (4-amp) fuse blown
5. No (external) compressed air to steam damper...80 PSI required
4. Failed steam damper 24 VAC pneumatic solenoid switch
5. Failed steam damper air piston

6. Failed microprocessor controller (computer)

**J. Dryer operates but is taking too long to dry**

1. Heating unit (GAS MODELS and ELECTRIC MODELS ONLY) is cycling on hi-limit thermostat (refer to **Item K** on the following page [[page 66](#)])

2. Exhaust duct work run too long or is undersized...back pressure cannot exceed .3 inches W.C.

3. Restriction in exhaust

a. Customer furnished exhaust back draft damper is sticking partially closed

b. Restriction in duct work...check duct work from dryer all the way to the outdoors

4. Low and/or inconsistent gas pressure (GAS MODELS ONLY)

5. Insufficient make-up air

6. Poor air/gas mixture at burner...yellow or poor flame pattern. Adjust gas burner air adjustment shutters (GAS MODELS ONLY)

7. Lint screen not being cleaned on a regular basis or often enough

a. Lint accumulation in location exhaust duct work

8. Extractors (washers) not performing properly

9. Sail switch is fluttering (GAS MODELS and ELECTRIC MODELS ONLY)

a. Restriction in location exhaust system

10. Failed microprocessor controller (computer)

a. Temperature calibration is inaccurate

11. Failed microprocessor temperature sensor

a. Calibration is inaccurate

12. Failed burner hi-limit (GAS MODELS ONLY)

13. Failed lint chamber hi-heat protector thermostat

14. Faulty electric oven element or elements (ELECTRIC MODELS ONLY)

a. Faulty/failed element or elements

b. Failed oven contactor (relay)

15. Steam damper system not functioning properly (STEAM MODELS ONLY)

- a. Steam dampers sticking closed
- b. Leak in pneumatic system

16. Blower (impellor/ fan) motor rotation direction incorrect

**K. Dryer is cycling on hi-limit thermostat (GAS MODELS and ELECTRIC MODELS ONLY)**

- 1. Blower (impellor/ fan) motor failure
- 2. Blower (impellor/ fan) motor rotation direction incorrect
- 3. Insufficient make-up air
- 4. Restriction in location exhaust system
  - a. Undersize exhaust ducting
- 5. Lint screen not being cleaned on a regular basis or often enough
  - a. Lint accumulation in location exhaust duct work
- 6. Faulty hi-limit thermostat
- 7. Faulty microprocessor controller (computer)

**L. Microprocessor controller (computer) L.E.D. display reads "dSFL"**

- 1. Fault in microprocessor heat sensing circuit
  - a. Failed microprocessor temperature sensor
  - b. Failed microprocessor controller (computer)
  - c. Broken wire or connection somewhere between the microprocessor controller (computer) and the microprocessor temperature sensor

**M. Microprocessor controller (computer) L.E.D. display reads "door"**

- 1. Fault (open circuit) in D.C. door switch circuit
  - a. Failed main door switch
  - b. Broken connection/ wire in D.C. main door or lint door circuit

**N. Microprocessor controller (computer) will not accept any keyboard (touchpad) entries, i.e., L.E.D. display reads "FILL" and when keyboard (touchpad) entries are selected, the L.E.D. display continues to read "FILL"**

1. Failed keyboard label (touchpad) assembly
2. Failed microprocessor controller (computer)

**O. Microprocessor controller (computer) accepts keyboard (touchpad) entry but dryer does not start... various L.E.D. display codes are shown for a few seconds and then L.E.D. display returns to "FILL"**

1. Fault (open circuit) in D.C. door switch circuit
  - a. Failed main door switch
  - b. Broken connection/wire in D.C. main door or lint drawer switch

**P. Microprocessor controller (computer) will only accept certain keyboard (touchpad) entries**

1. Failed keyboard label (touchpad) assembly
2. Failed microprocessor controller (computer)

**Q. Microprocessor controller (computer) locks up and L.E.D. display reads erroneous message(s) or only partial segments**

1. Transient power voltage (spikes)...disconnect power to dryer, wait one (1) minute and re-establish power to dryer. If problem is still evident:
  - a. Failed microprocessor controller (computer)
  - b. Failed keyboard label (touchpad) assembly

**R. Dryer stops during a cycle and L.E.D. display returns to "FILL"**

1. Fault in microprocessor heat sensor circuit
  - a. Loose connection in wires between temperature sensor and microprocessor controller (computer)
2. Loose connection somewhere in main power circuit to microprocessor controller (computer)

**S. Gas heating unit is not operating (no heat)...no spark at burner area when dryer is first started and heat indicator light/dot is on (GAS MODELS ONLY)**

1. Fault in sail switch circuit
  - a. Sail switch is out of adjustment or has failed

b. Sail switch damper is not closing or is fluttering

- 1) Lint screen is dirty
- 2) Restriction in exhaust

2. Fault in burner hi-limit circuit or thermostat
3. Fault in lint chamber sensor bracket hi-heat protector thermostat
4. Failed Direct Spark Ignition (DSI) module
5. Failed DSI ignitor/ flame-probe assembly
6. Failed microprocessor controller (computer)

**T. Condensation on main door glass**

1. Too long, undersized, or improperly installed duct work
2. Dryer connected to common exhaust duct with another dryer and no back draft damper was installed in customer furnished duct work
3. Customer furnished back draft damper in duct work is sticking in partially closed position

**U. Dryer or scraping noise at basket (tumbler) area**

1. Check for object caught in basket (tumbler)/ wrapper area
2. Basket (tumbler) is out of proper alignment
  - a. Check both vertical and lateral alignment
  - b. Check gap between front panel and set screws may have come loose and basket (tumbler) walked forward or back
3. Loose basket (tumbler) tie rod
4. Failed basket (tumbler) support

**V. Excessive noise and/or vibration**

1. Dryer is not leveled properly
2. Impellor (fan) out of balance
  - a. Excessive lint build up on impellor (fan)
  - b. Failed impellor (fan)

3. Loose basket (tumbler) tie rod
4. Basket (tumbler) out of adjustment or adjustment bolts (hardware) are loose
5. Failed basket (tumbler) support
6. Loose motor mount
7. Failed idler bearing(s) and/or tumbler bearing(s)
8. V-belt(s) either too tight or too loose

### *Dual Timer Models*

**A. Dryer will not start...both the drive motor and the blower (impellor/fan) motor are not operating (indicator light/dot is off)**

1. Dryer control circuit fuse is blown
2. Open at location service main fuse or circuit breaker
3. Failed push to start relay
4. Faulty door switch and/or door switch circuit
5. Failed heat timer
6. Failed dual timer relay

**B. Drive motor (only) not operating**

1. Failed drive motor contactor (relay)
2. Failed reversing timer (reversing timer only)
3. Failed drive motor

**C. Blower (impellor/fan) motor (only) not operating**

1. Failed impellor (fan) motor contactor (relay)
2. Failed blower (impellor/ fan) motor

**D. Both the drive motor and the blower (impellor/fan) motor are not operating (indicator light/dot is on)**

1. Fault with L1 termination at reversing timer (reversing models only)



**E. Reversing drive motor operates in one direction only...stops and restarts in same direction (reversing models only)**

1. Failed reversing contactor (relay)
2. Failed reversing timer

**F. Heating unit not operating (all temperature selections)...**

**GAS MODELS ONLY**

1. Fault in sail switch circuit
  - a. Sail switch out of adjustment and/or faulty (failed)
  - b. Sail switch not closing or fluttering
    - 1) Check blower (impellor/fan) motor and rotation direction
    - 2) Restriction in location exhaust system
2. Failed burner hi-limit
3. Failed lint compartment automatic (225°) safety thermostat
4. Failed heat selector switch
5. Fault in Direct Spark Ignition (DSI) system circuit  
(refer to **Section IV, page 42 through page 54**)

**ELECTRIC MODELS ONLY**

1. Fault in sail switch circuit
  - a. Sail switch out of adjustment and/or faulty (failed)
  - b. Sail switch not closing or fluttering
    - 1) Check blower (impellor/fan) motor and rotation direction
    - 2) Restriction in location exhaust system
2. Failed oven hi-limit
3. Failed lint compartment automatic (225°) safety thermostat
4. Failed oven contactor (relay)

5. Failed heat selector switch

### **STEAM MODELS ONLY**

1. Steam dampers binding and/or stuck in the closed position
2. Failed lint compartment automatic (225°) safety thermostat
3. Fault in lint chamber sensor bracket hi-heat (limit) protector thermostat
4. Failed steam damper air piston
5. Failed heat selector switch

#### **G. Heating unit is not operating for one (1) temperature selection**

1. Failed thermostat corresponding to the selection made

#### **H. Dryer operates but is taking too long to dry**

1. Heating unit (GAS MODELS and ELECTRIC MODELS ONLY) is cycling on hi-limit thermostat (refer to **Item I** on the following page [\[page 71\]](#))
2. Exhaust duct work run too long or is undersized...back pressure cannot exceed .3 inches W.C.
3. Restriction in exhaust
  - a. Customer furnished exhaust back draft damper is sticking partially closed
  - b. Restriction in duct work...check duct work from dryer all the way to the outdoors
4. Low and/or inconsistent gas pressure (GAS MODELS ONLY)
5. Insufficient make-up air
6. Poor air/gas mixture at burner...yellow or poor flame pattern. Adjust gas burner air adjustment shutters (GAS MODELS ONLY)
7. Lint screen not being cleaned on a regular basis or often enough
  - a. Lint accumulation in location exhaust duct work
8. Extractors (washers) not performing properly
9. Sail switch is fluttering (GAS MODELS and ELECTRIC MODELS ONLY)
  - a. Restriction in location exhaust system

10. Failed microprocessor controller (computer)
  - a. Temperature calibration is inaccurate
11. Failed microprocessor temperature sensor
  - a. Calibration is inaccurate
12. Failed burner hi-limit (GAS MODELS ONLY)
13. Failed lint chamber hi-heat protector thermostat
14. Faulty electric oven element or elements (ELECTRIC MODELS ONLY)
  - a. Faulty/failed element or elements
  - b. Failed oven contactor (relay)
15. Steam damper system not functioning properly (STEAM MODELS ONLY)
  - a. Steam dampers sticking closed
  - b. Leak in pneumatic system
16. Blower (impellor/ fan) motor rotation direction incorrect
- I. Dryer is cycling on hi-limit thermostat (GAS MODELS and ELECTRIC MODELS ONLY)**
  1. Blower (impellor/ fan) motor failure
  2. Blower (impellor/ fan) motor rotation direction incorrect
  3. Insufficient make-up air
  4. Restriction in location exhaust system
    - a. Undersize exhaust ducting
  5. Lint screen not being cleaned on a regular basis or often enough
    - a. Lint accumulation in location exhaust duct work
  6. Faulty hi-limit thermostat
  7. Faulty electric oven contactor/relay (ELECTRIC MODELS ONLY)

**J. Motor(s) keeps overheating and/or tripping out on internal overload protector**

1. Exceptionally low or exceptionally high voltage supply
2. Motor(s) air vents are blocked with lint and/or dirt
3. Faulty idler bearing(s) and or tumbler bearing(s)
4. V -belt(s) too tight
5. Faulty motor(s)

**K. Main burners are burning with a yellow flame (GAS MODELS ONLY)**

1. Poor air/ gas mixture at burner
  - a. Adjust gas burner air adjustment shutters
2. Insufficient make up air
3. Dust and/or lint in the burner

**L. Condensation on main door glass**

1. Too long, undersized, or improperly installed duct work
2. Dryer connected to common exhaust duct with another dryer and no back draft damper was installed in customer furnished duct work
3. Customer furnished back draft damper in duct work is sticking in partially closed position

**M. Dryer or scraping noise at basket (tumbler) area**

1. Check for object caught in basket (tumbler)/ wrapper area
2. Basket (tumbler) is out of proper alignment
  - a. Check both vertical and lateral alignment
  - b. Check gap between front panel and set screws may have come loose and basket (tumbler) walked forward or back
3. Loose basket (tumbler) tie rod
4. Failed basket (tumbler) support

**N. Excessive noise and/or vibration**

1. Dryer is not leveled properly

2. Impellor (fan) out of balance
  - a. Excessive lint build up on impellor (fan)
  - b. Failed impellor (fan)
3. Loose basket (tumbler) tie rod
4. Basket (tumbler) out of adjustment or adjustment bolts (hardware) are loose
5. Failed basket (tumbler) support
6. Loose motor mount
7. Failed idler bearing(s) and/or tumbler bearing(s)
8. V-belt(s) either too tight or too loose

ADC 112125 1 - 01/90-----250 2 - 05/15/92-100 3 \* 12/11/92-100  
4 \* 08/02/93-100 5 - 11/04/97-25

