

Speed Queen

A **Raytheon** Company

Parts and Service Manual for Commercial Automatic Washers (WA Models)

▲ WARNING

FAILURE TO INSTALL, MAINTAIN, AND/OR OPERATE THIS MACHINE ACCORDING TO MANUFACTURER'S INSTRUCTIONS MAY RESULT IN CONDITIONS WHICH CAN PRODUCE BODILY INJURY AND/OR PROPERTY DAMAGE.

NOTE: The **WARNING** and **IMPORTANT** instructions appearing in this manual are not meant to cover all possible conditions and situations that may occur. It must be understood that common sense, caution and carefulness are factors which **CANNOT** be built into this washer. These factors **MUST BE** supplied by the person(s) installing, maintaining or operating the washer.

Always contact your dealer, distributor, service agent or the manufacturer about any problems or conditions you do not understand.

INFORMATION CONTAINED IN THIS MANUAL IS APPLICABLE TO THESE WASHERS

Model Numbers	Metered Models	Non-Metered Models	One Speed Motor	Two Speed Motor	Porcelain Washtub	Stainless Steel Washtub
WA4710		X	X		X	
WA4711		X	X			X
WA4720		X		X	X	
WA4721		X		X		X
WA4950 and WA4960	X		X		X	
WA4951 and WA4961	X		X			X
WA4970 and WA4980	X			X	X	
WA4971 and WA4981	X			X		X

IMPORTANT

When writing for information on any washer, be sure to mention model and serial numbers. The model and serial numbers will be found on the nameplate as shown.

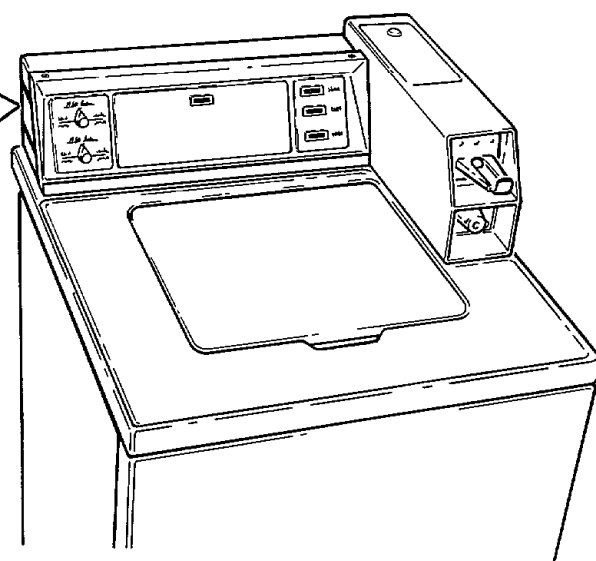

TABLE OF CONTENTS

Important Information	
Nameplate Location	1

SECTION I Parts

Control Panel, Control Hood and Controls	3
Timer, Meter Case and Service Door (Metered Models)	4
Timer, Case and Plate (Nonmetered Models)	5
Cabinet Top and Loading Door	6
Switch and Bracket Assembly	7
Inlet Hose, Filler Hose, Backflow Preventer and Mixing Valve Mounting Bracket	8, 9
Mixing Valve Assembly	10
Agitator, Drive Bell and Seal Seat (Short Post Models)	11
Agitator and Post (Long Post Models)	12
Lint Filter, Washtub and Hub	13, 14
Outer Tub, Cover and Pressure Hose	15
Motor, Mounting Brackets, Belts and Idler Assembly	16
Transmission Assembly and Balance Ring (Short Post Models)	17
Components for 30978 Transmission Assembly (Short Post Models)	18
Transmission Assembly and Balance Ring (Long Post Models)	19
Components for 28430 Transmission Assembly (Long Post Models)	20
Components for 30123 and 30946 Transmission Assemblies (Long Post Models)	21
Bearing Housing, Brake, Pulley and Pivot Dome	22
Pump Assembly, Bracket, Hoses and Siphon Break Kit	23
Pump Assembly	24
Front Panel, Cabinet and Base	25
Power Cord Wire and Terminals	26
Special Tools	27, 28

SECTION II Service Procedures

1. Control Panel	29
2. Speed or Wash Temperature Switch	29
3. Indicator Lights – IN USE, RINSE, SPIN or UNBALANCED LOAD	29
4. Timer Assembly – Metered Models	30
5. Timer Assembly – Nonmetered Models	30
6. Meter Case	31
7. Timer Case	31
8. Pressure Switch	32
9. Drain Hose Elbow	32
10. Loading Door	32
11. Agitator (Short Post Models)	33
12. Agitator Drive Bell and Seal Seat Assembly (Short Post Models)	33
13. Agitator Post Assembly (Long Post Models)	35
14. Agitator Drive Shaft (Long Post Models)	36

15. Front Panel	36
16. Pump Belt	36
17. Drive Belt	37
18. Motor and Mounting Bracket	37
19. Idler Lever and Pulley	38
20. Motor Drive Pulley or Pump Pulley	38
21. Motor Switch	38
22. Pump Assembly	40
23. Cabinet Top Assembly	40
24. Door and Out-Of-Balance Switch and Bracket Assembly	42
25. Mixing Valve Assembly	42
26. Washtub and Lint Filter	43
27. Water Seal and Hub Assembly (Short Post Models)	45
28. Water Seal Assembly (Long Post Models)	48
29. Outer Tub	50
30. Drive Pulley and Helix	54
31. Brake Assembly	55
32. Lower Bearing Housing	56
33. Transmission Assembly	57
34. Balance Ring	64
35. Upper Bearing Assembly	64
36. Snubber Pads	65

SECTION III Adjustments

37. Leveling Legs	67
38. Pressure Switch	67
39. Belt (Agitate & Spin)	67
40. Belt (Pump)	68
41. Out-Of-Balance Switch Trigger	68

SECTION IV Service Helps

42. No Hot Water	69
43. No Cold Water	69
44. No Warm Water	70
45. Water Fill Does Not Stop At Proper Level	70
46. Timer Does Not Advance	70
47. No Agitation	71
48. Constant Agitation	71
49. Slow Spin or No Spin	72
50. Constant Spin	72
51. Drive Motor Overload Protector Cycles Repeatedly	72
52. Outer Tub Does Not Empty	73
53. Excessive Vibration	73
54. Water Leaking From Outer Tub	73

SECTION V Test Procedures

SECTION VI Cycle Sequence Charts

SECTION VII Wiring Diagrams

SECTION I

Parts

CONTROL PANEL
 Models WA4710, WA4711, WA4950,
 WA4951, WA4960 and WA496129660
 Models WA4720, WA4721, WA4970,
 WA4971, WA4980 and WA498129661

*Add Suffix Letter To Part Number To Designate Color.
 H Harvest Gold L Almond
 W New White (Starting Serial No. 14G35561)
 S Old White (Through Serial No. 14G35560)

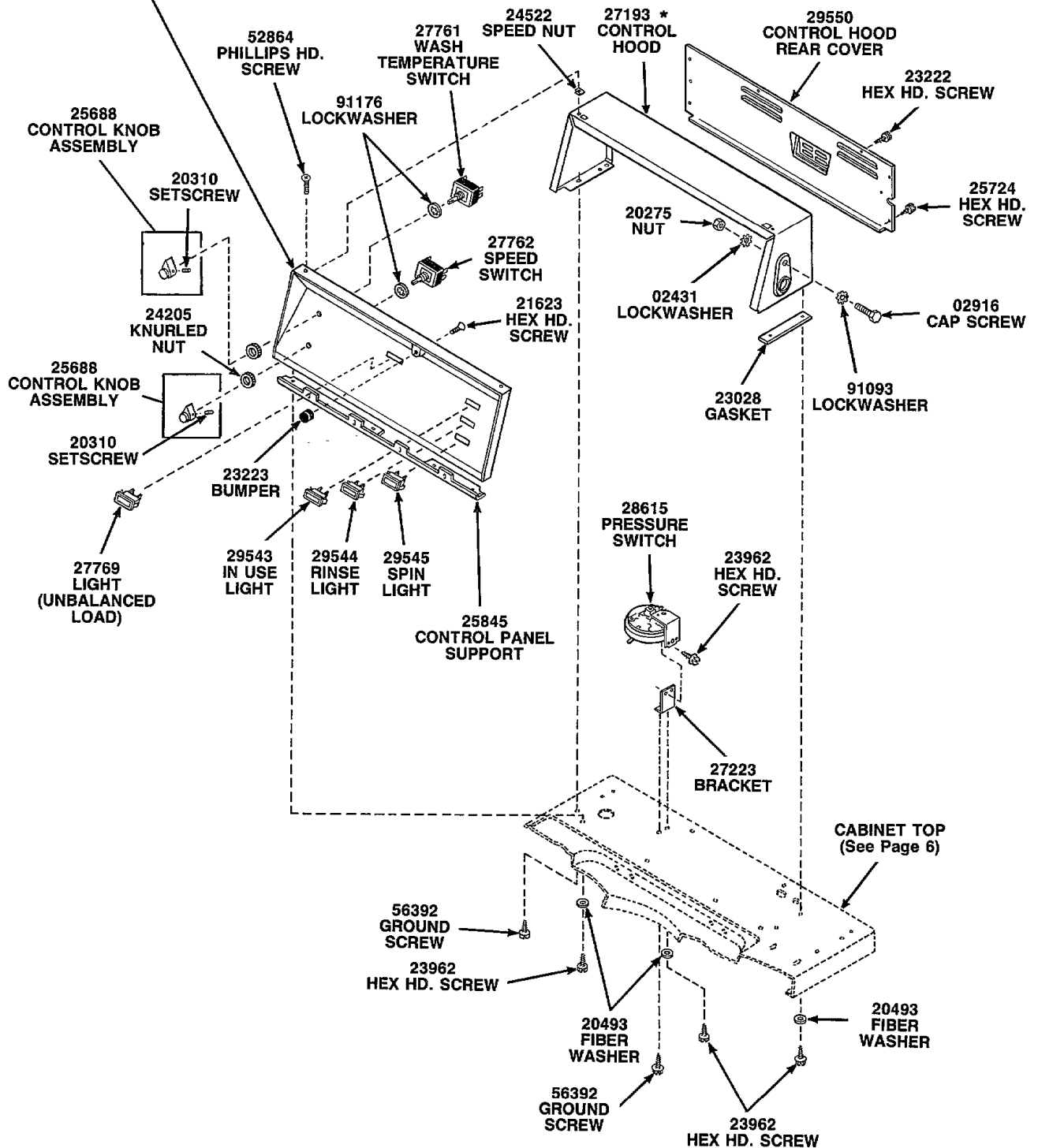

CONTROL PANEL, CONTROL HOOD AND CONTROLS

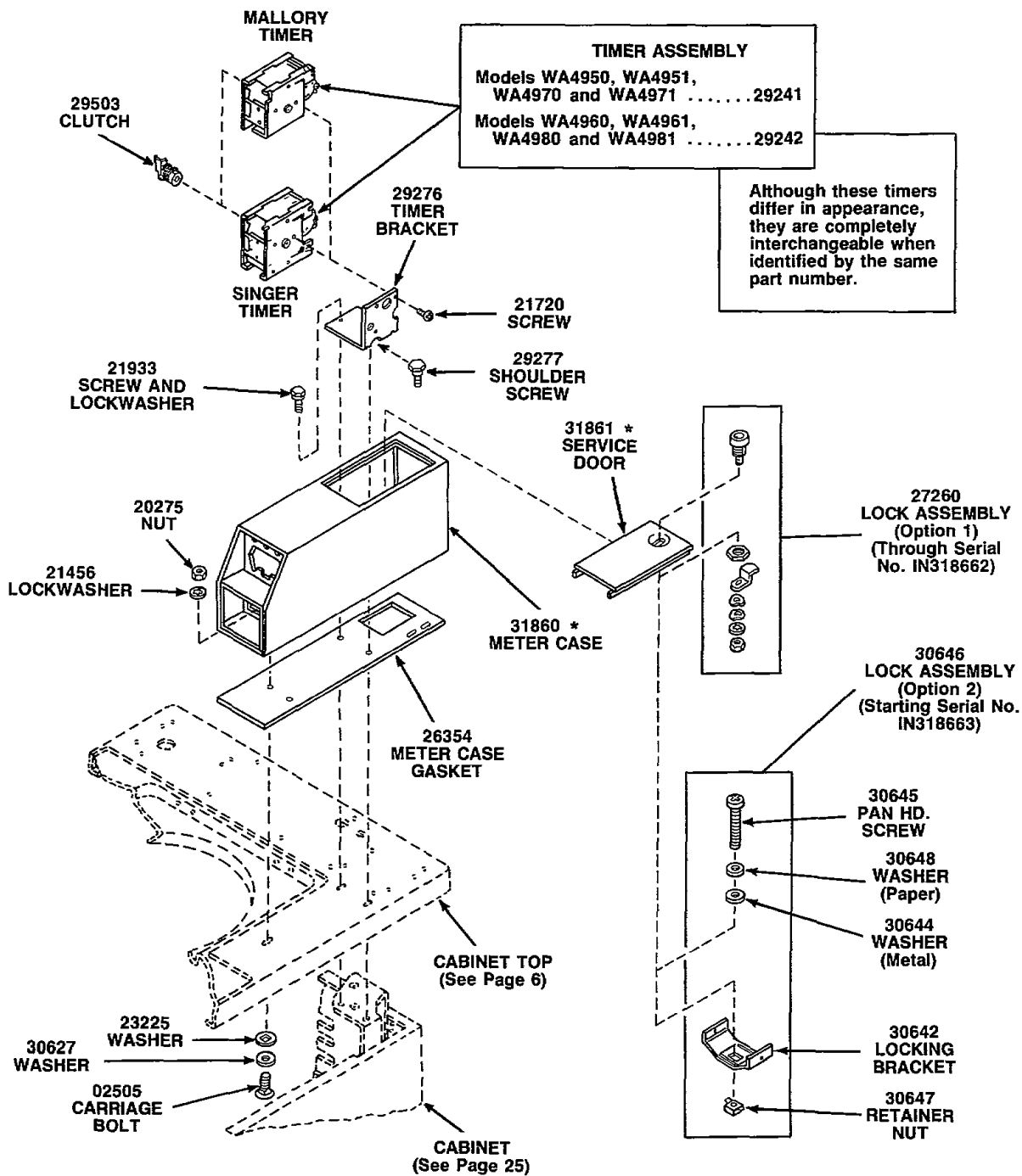

TIMER ASSEMBLY
 Models WA4950, WA4951, WA4970 and WA4971 29241
 Models WA4960, WA4961, WA4980 and WA4981 29242

Although these timers differ in appearance, they are completely interchangeable when identified by the same part number.

*Add Suffix Letter To Part Number To Designate Color.
 H Harvest Gold L Almond
 W New White (Starting Serial No. 14G35561)
 S Old White (Through Serial No. 14G35560)

**TIMER, METER CASE AND SERVICE DOOR
 (Metered Models)**

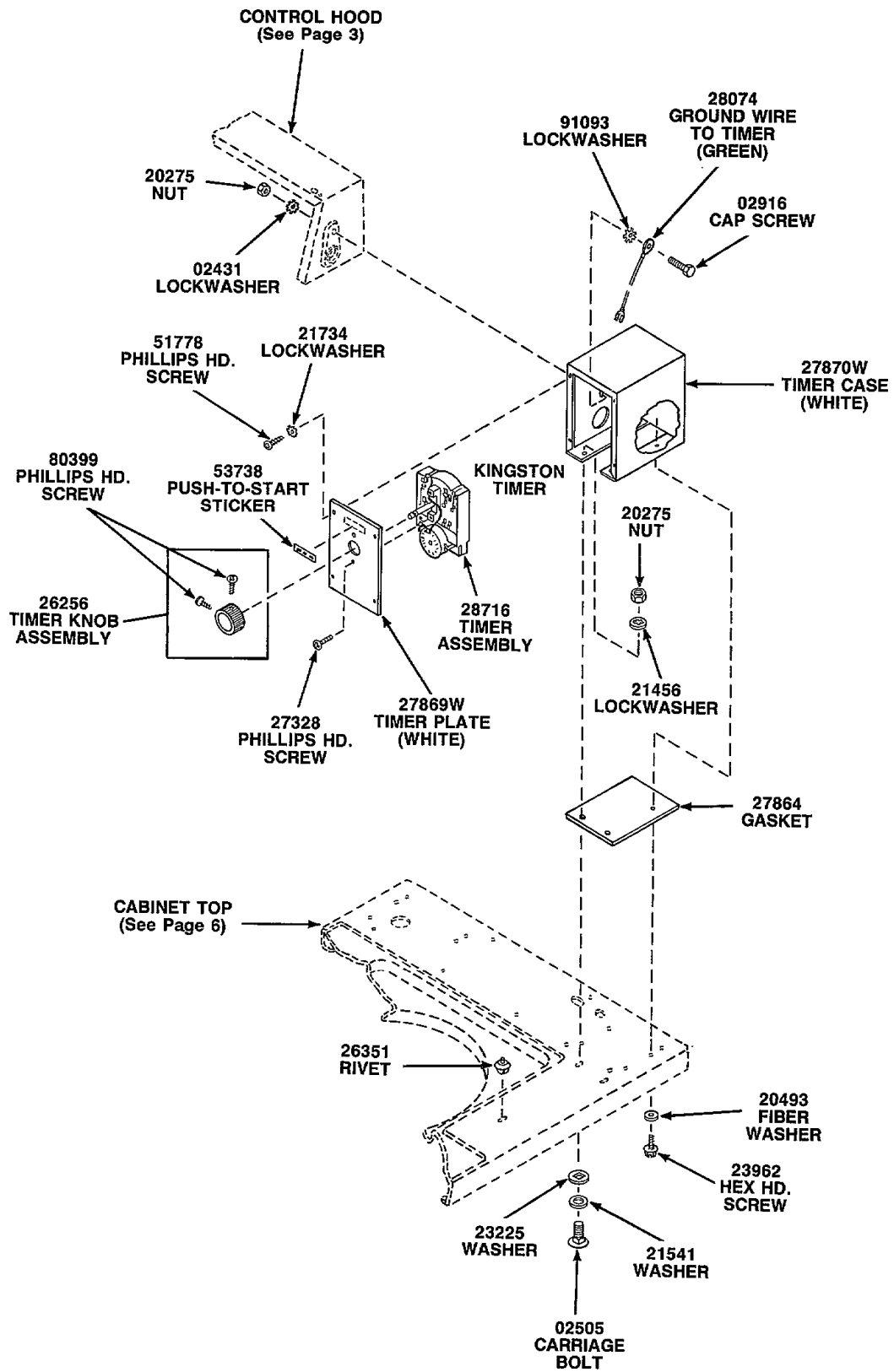

TIMER, CASE AND PLATE
 (Nonmetered Models)

*Add Suffix Letter To Part Number To Designate Color.

H Harvest Gold

L Almond

W New White (Starting Serial No. 14G35561)

S Old White (Through Serial No. 14G35560)

LOADING DOOR
Nonmetered Models28840W
Metered Models28841 *

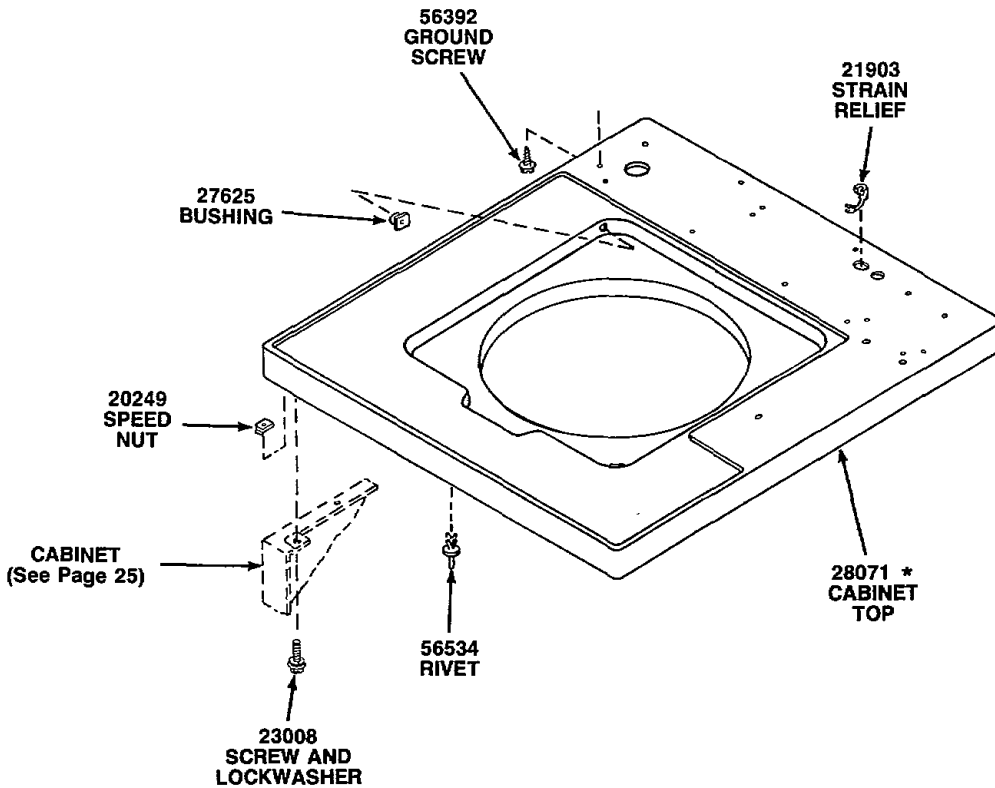
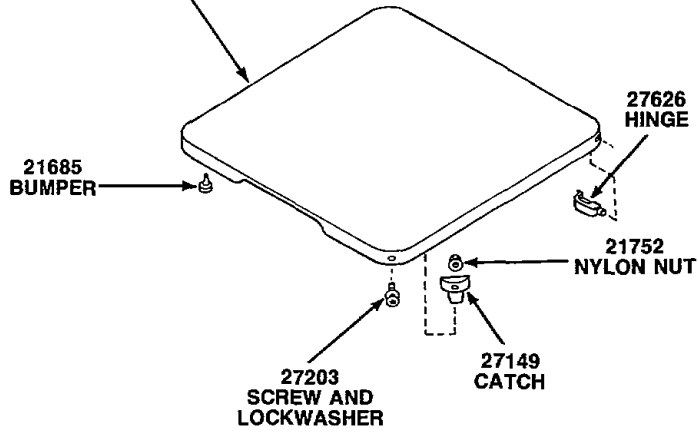

CABINET TOP AND LOADING DOOR

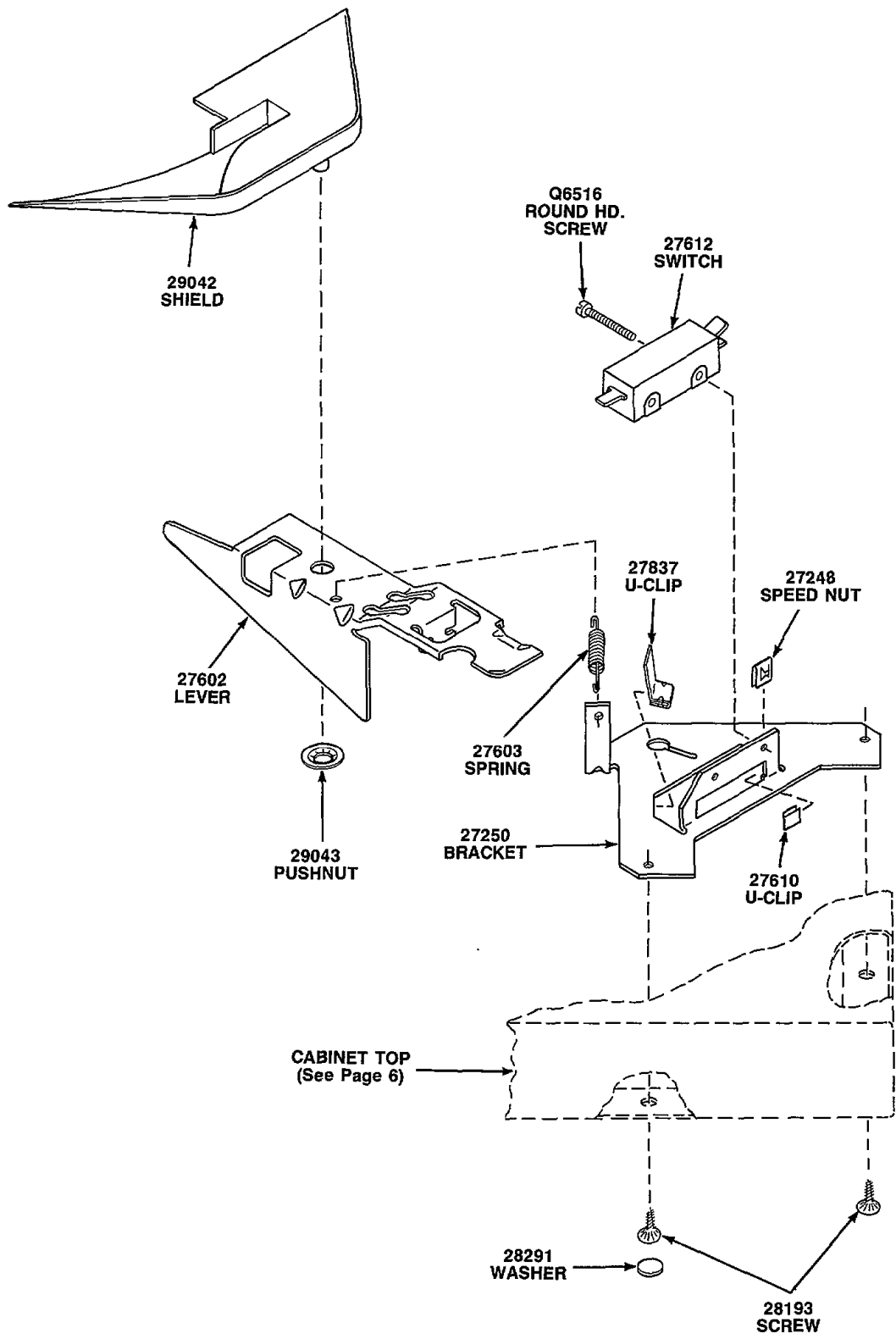

SWITCH AND BRACKET ASSEMBLY

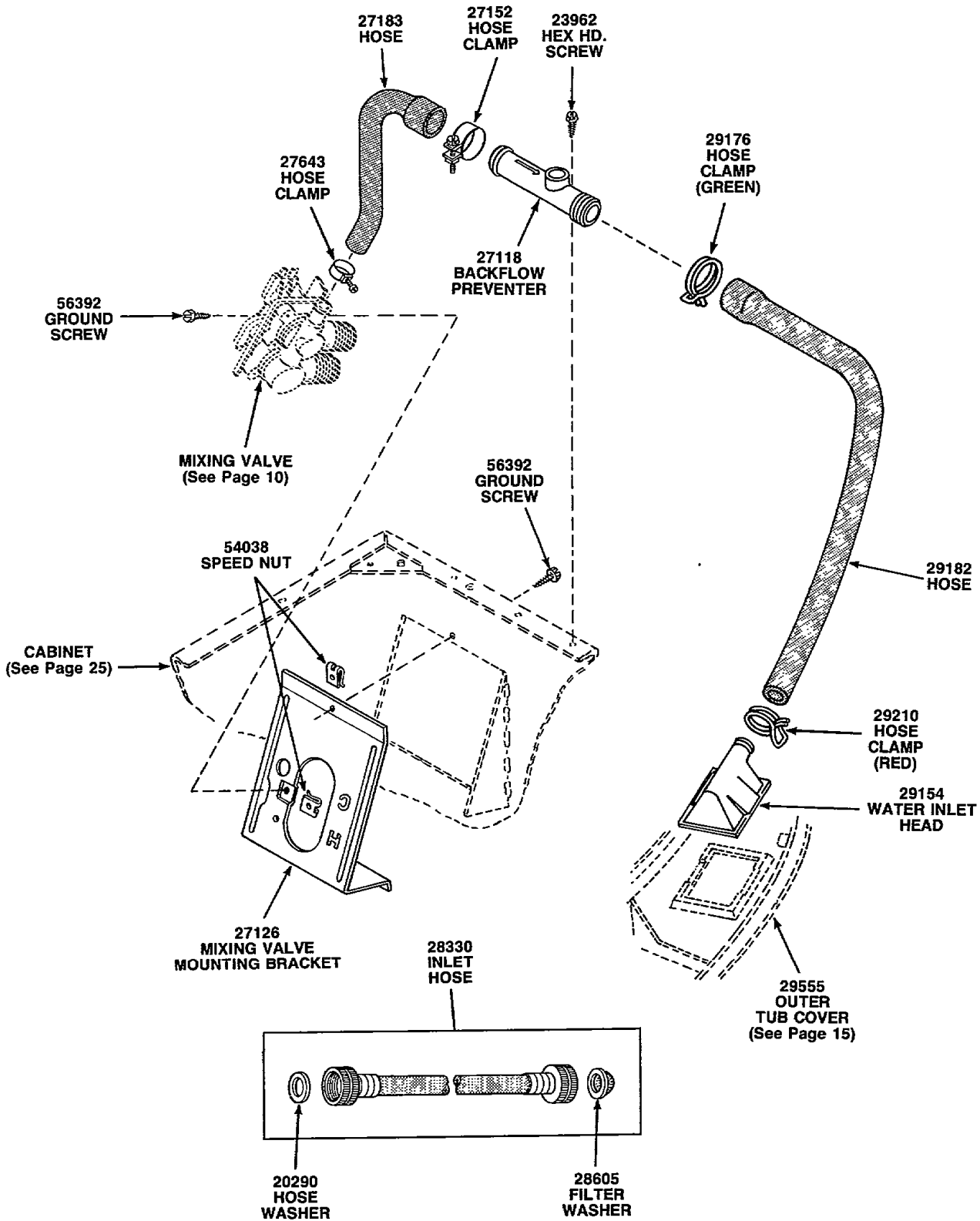

INLET HOSE, FILLER HOSE, BACKFLOW PREVENTER AND MIXING VALVE MOUNTING BRACKET
 (Through Serial No. 14F02861)

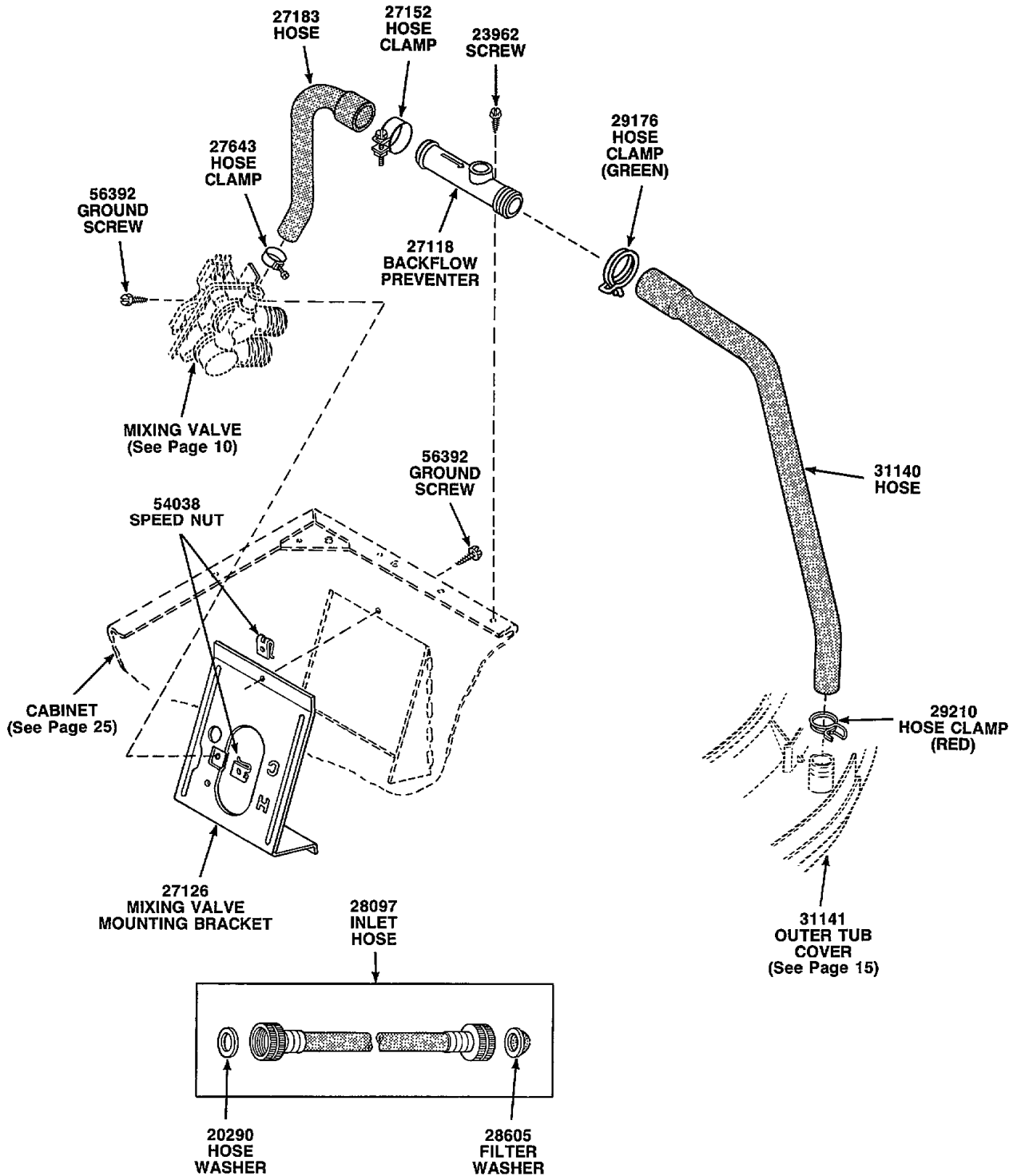

INLET HOSE, FILLER HOSE, BACKFLOW PREVENTER AND MIXING VALVE MOUNTING BRACKET
 (Starting Serial No. 14F02862)

27156
MIXING VALVE
ASSEMBLY

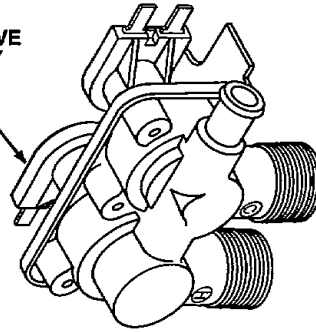

DOLE OR
EATON COMPANY

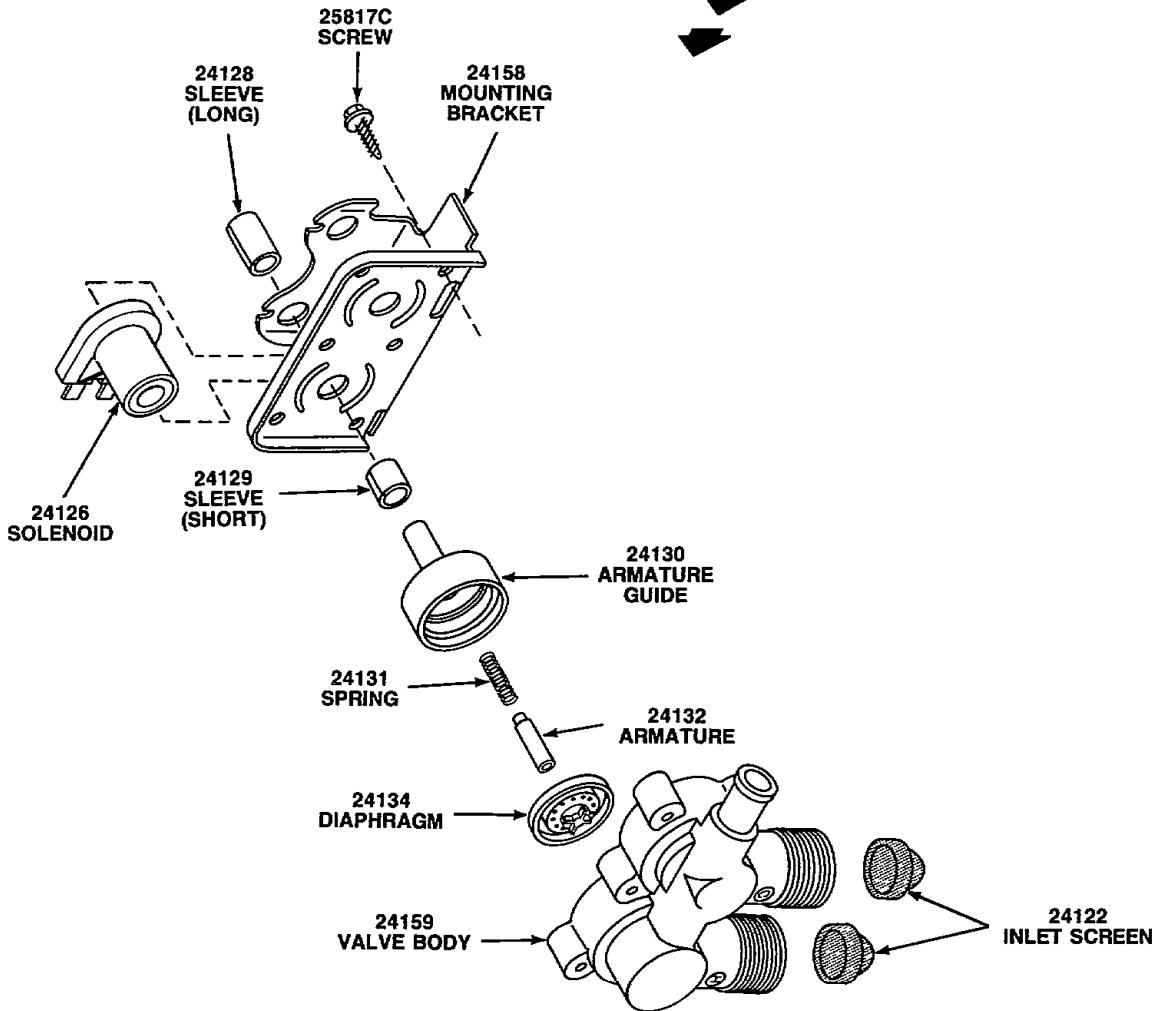
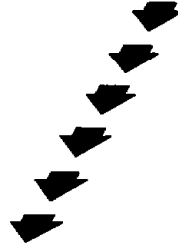

MIXING VALVE ASSEMBLY

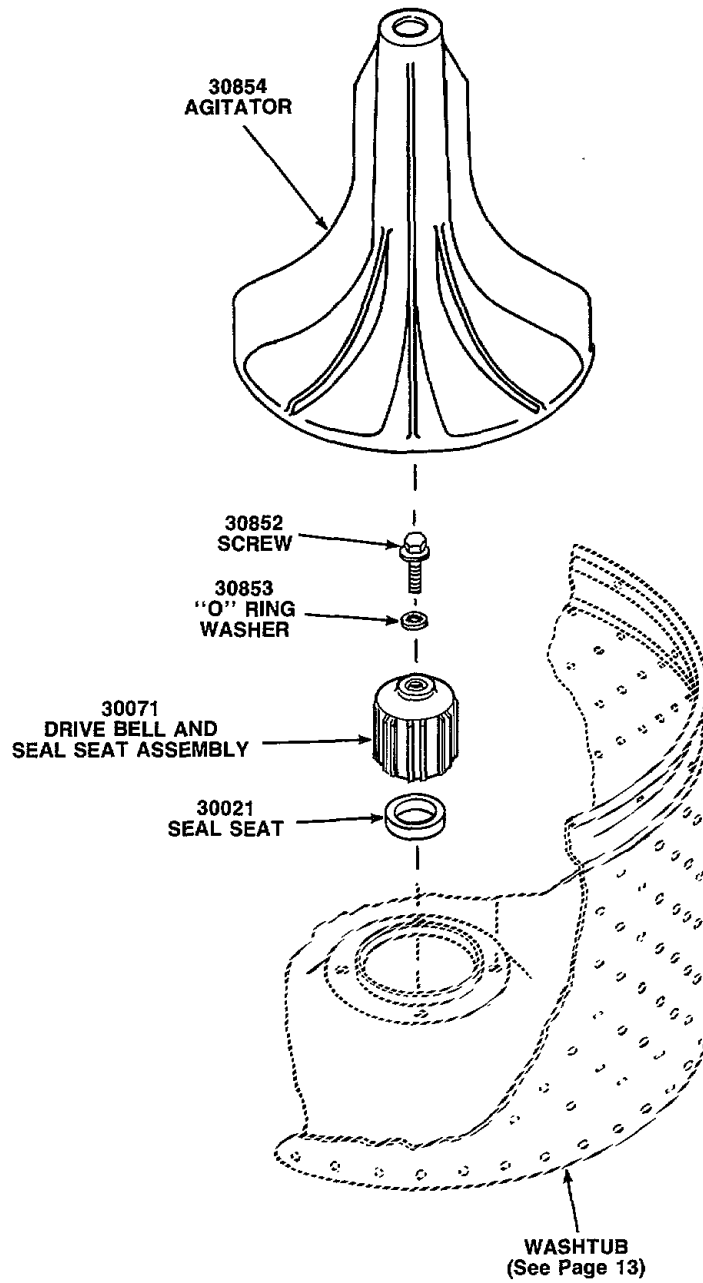

**AGITATOR, DRIVE BELL AND SEAL SEAT
(Short Post Models)**

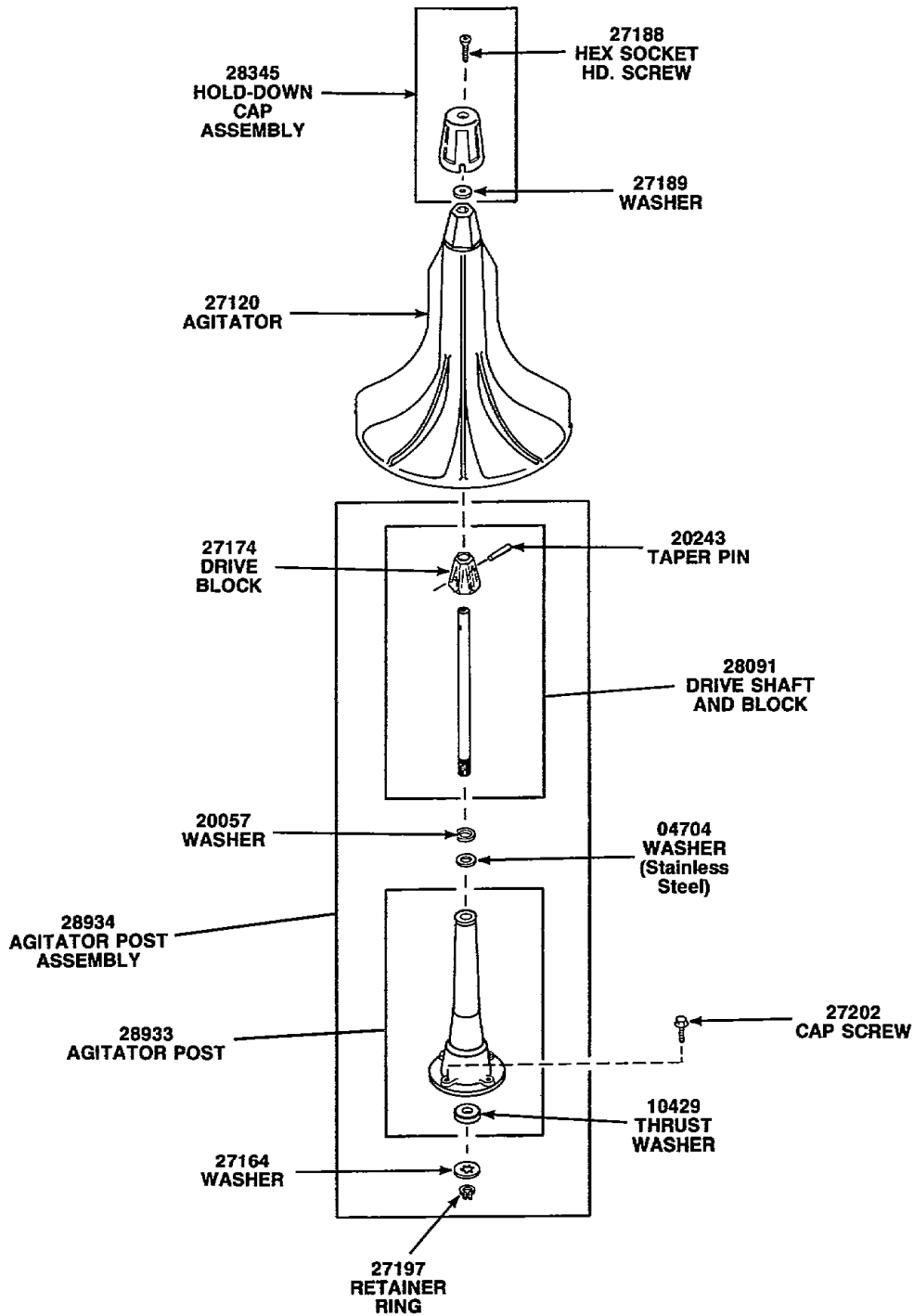

28434P LOCTITE
 (Use as a sealant on
 underside of Agitator Post.)

**AGITATOR AND POST
 (Long Post Models)**

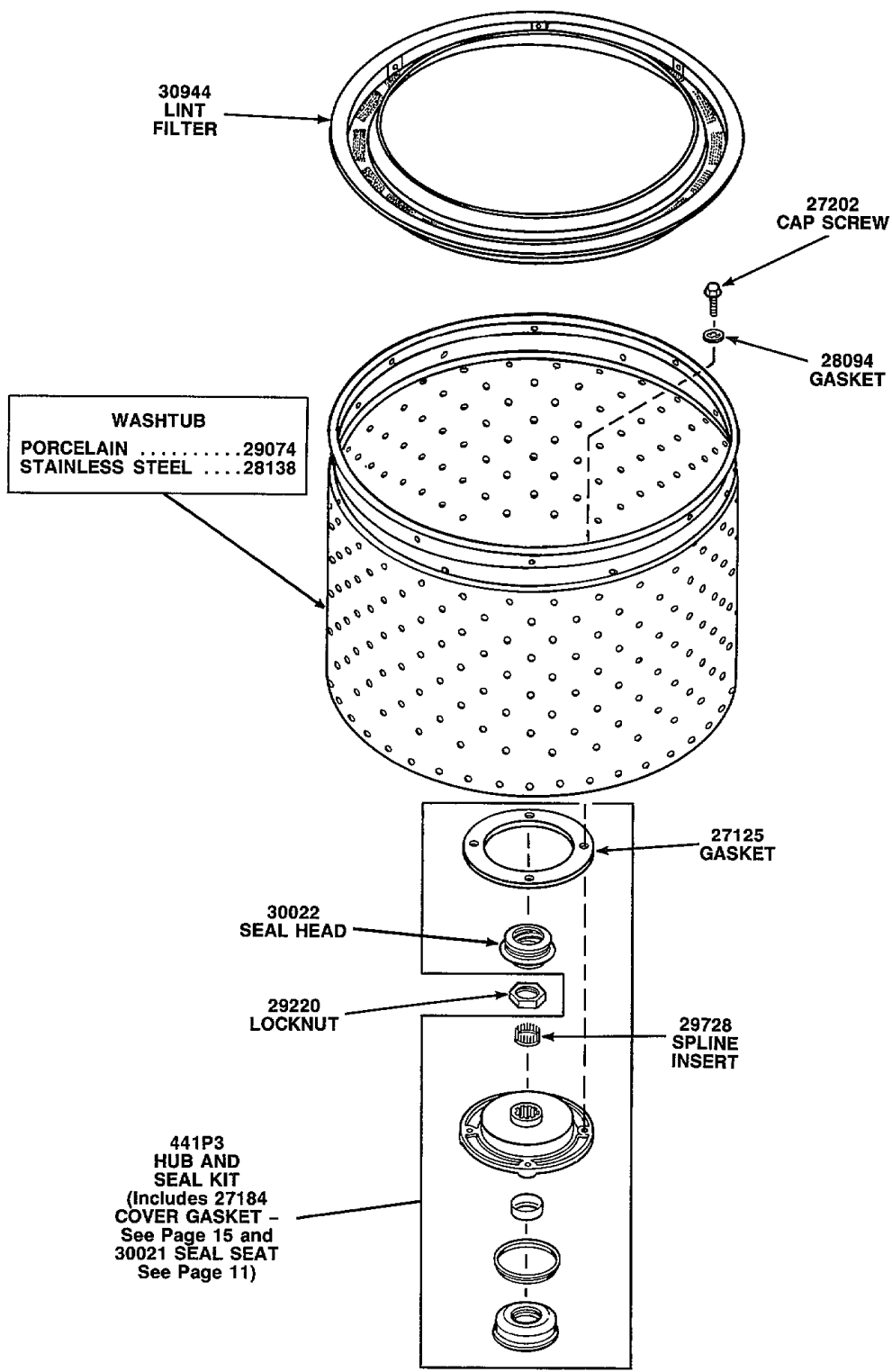

LINT FILTER, WASHTUB AND HUB
(Short Post Drive Models)

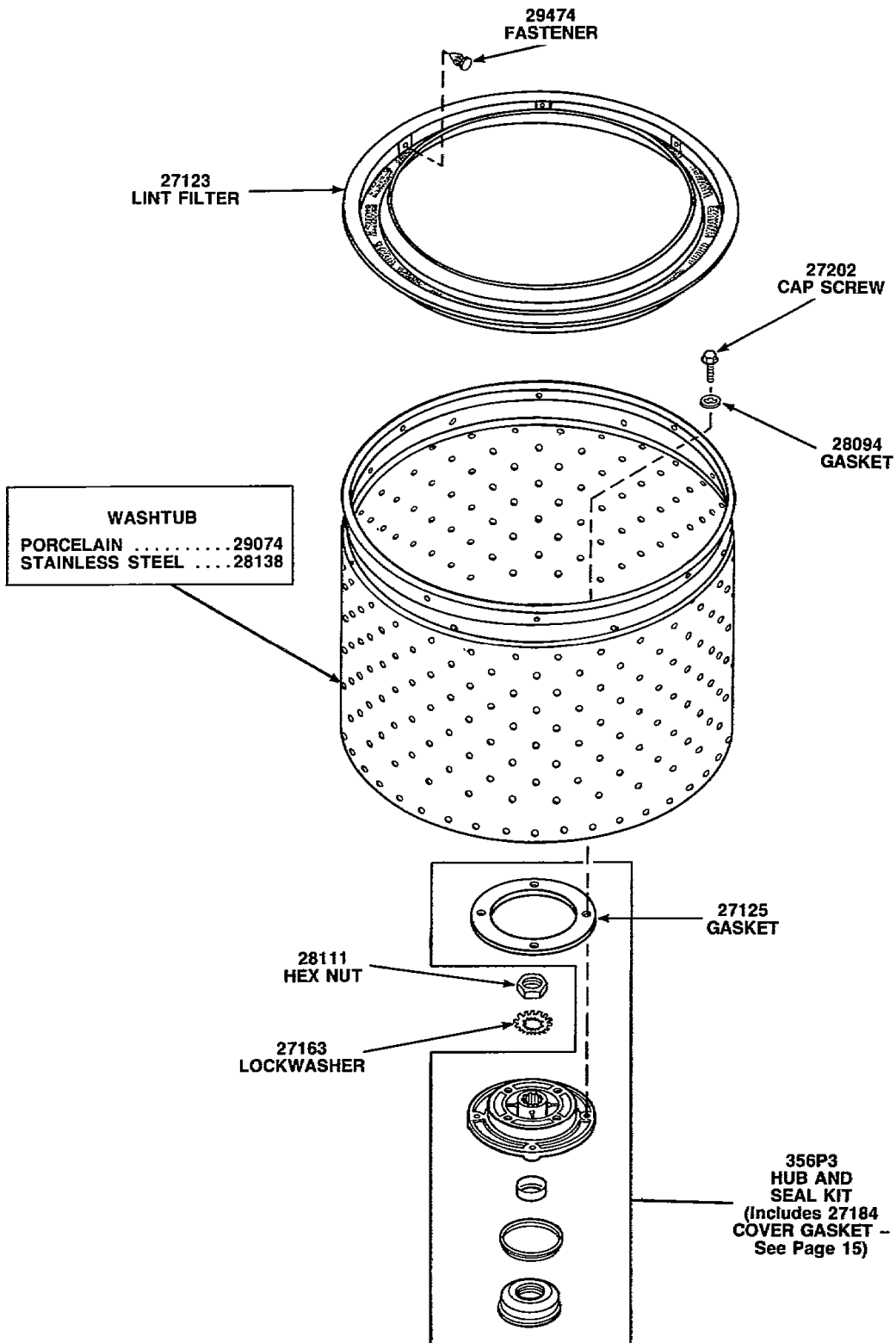

**LINT FILTER, WASHTUB AND HUB
(Long Post Drive Models)**

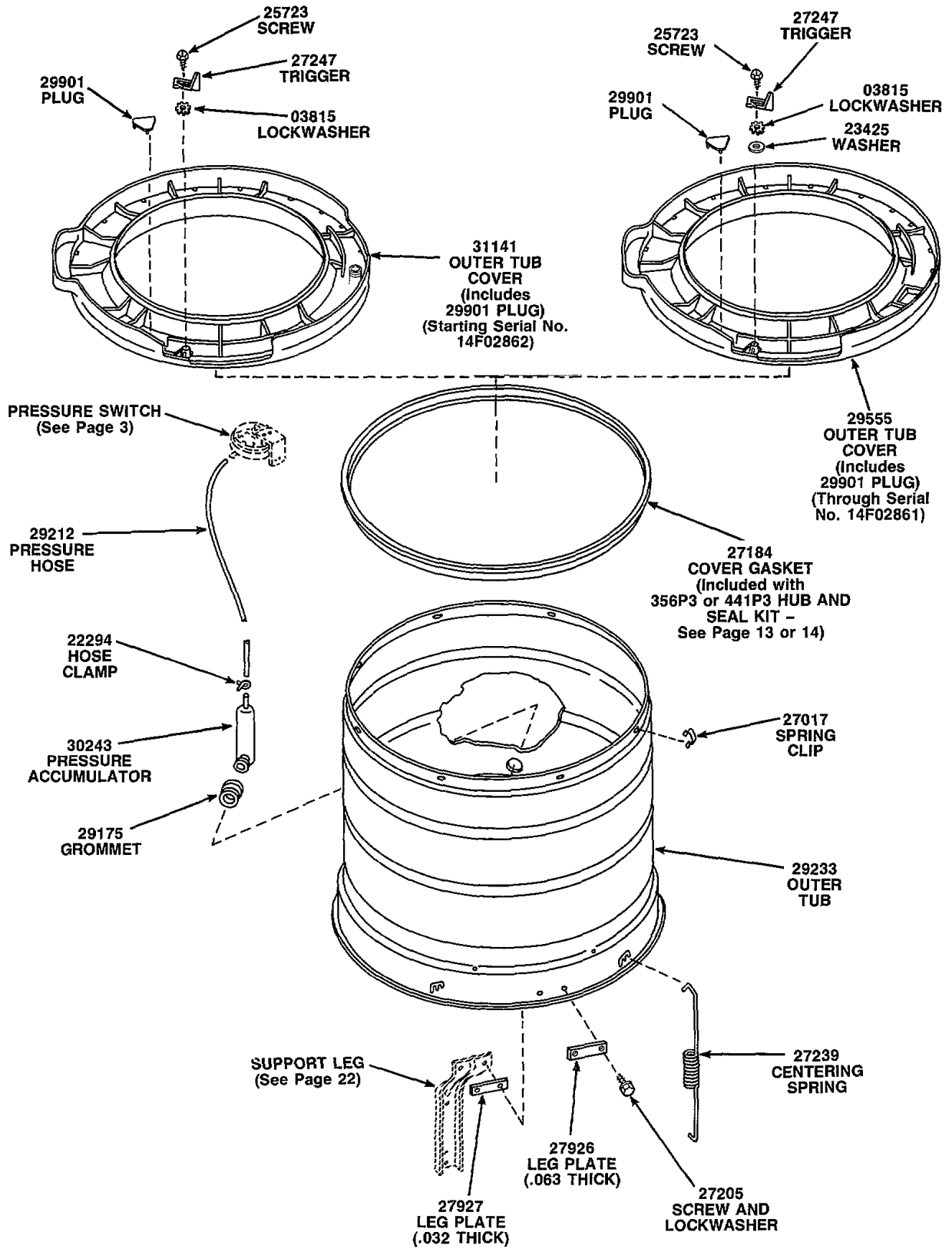

OUTER TUB, COVER AND PRESSURE HOSE

258P3 CAPACITOR KIT
(For use in areas where low voltage exists.)

MOTOR SWITCH
24139 (for Emerson Motor No. 27772 or 30895)
24140 (for Emerson Motor No. 27659 or 30897)
24142 (for General Electric Motor No. 27772)
24149 (for General Electric Motor No. 27659)
30895A (for General Electric Motor No. 30895)
30897A (for General Electric Motor No. 30897)

MOTOR
(120 Volt, 60 Hertz, 1 Phase)
Models WA4710, WA4711, WA4950, WA4951, WA4960 and WA4961 27658 (1 Speed)
Models WA4720, WA4721, WA4970, WA4971, WA4980 and WA4981 27179 (2 Speed)

MOTOR
NOTE: The individual motors are not available separately, order complete motor assemblies.
OLD STYLE
1 Speed Motor 27659
2 Speed Motor 27772
NEW STYLE
1 Speed Motor 30897
2 Speed Motor 30895

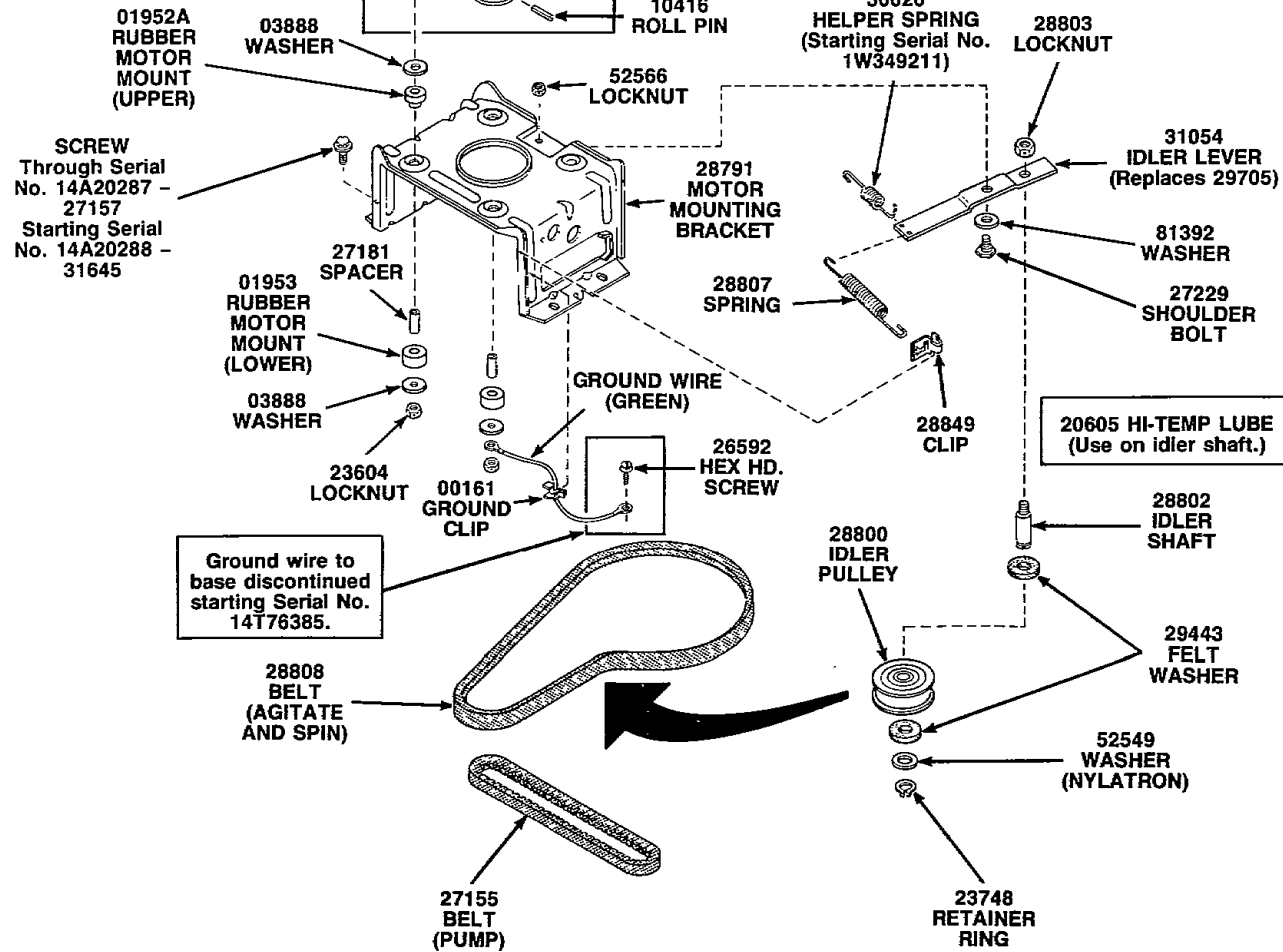
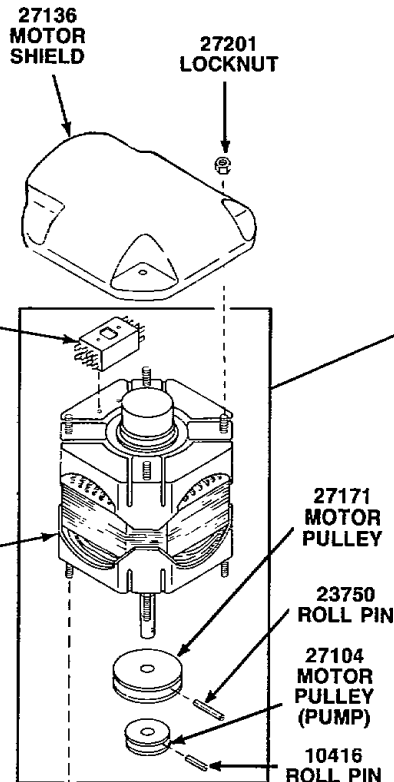

MOTOR, MOUNTING BRACKET, BELTS AND IDLER ASSEMBLY

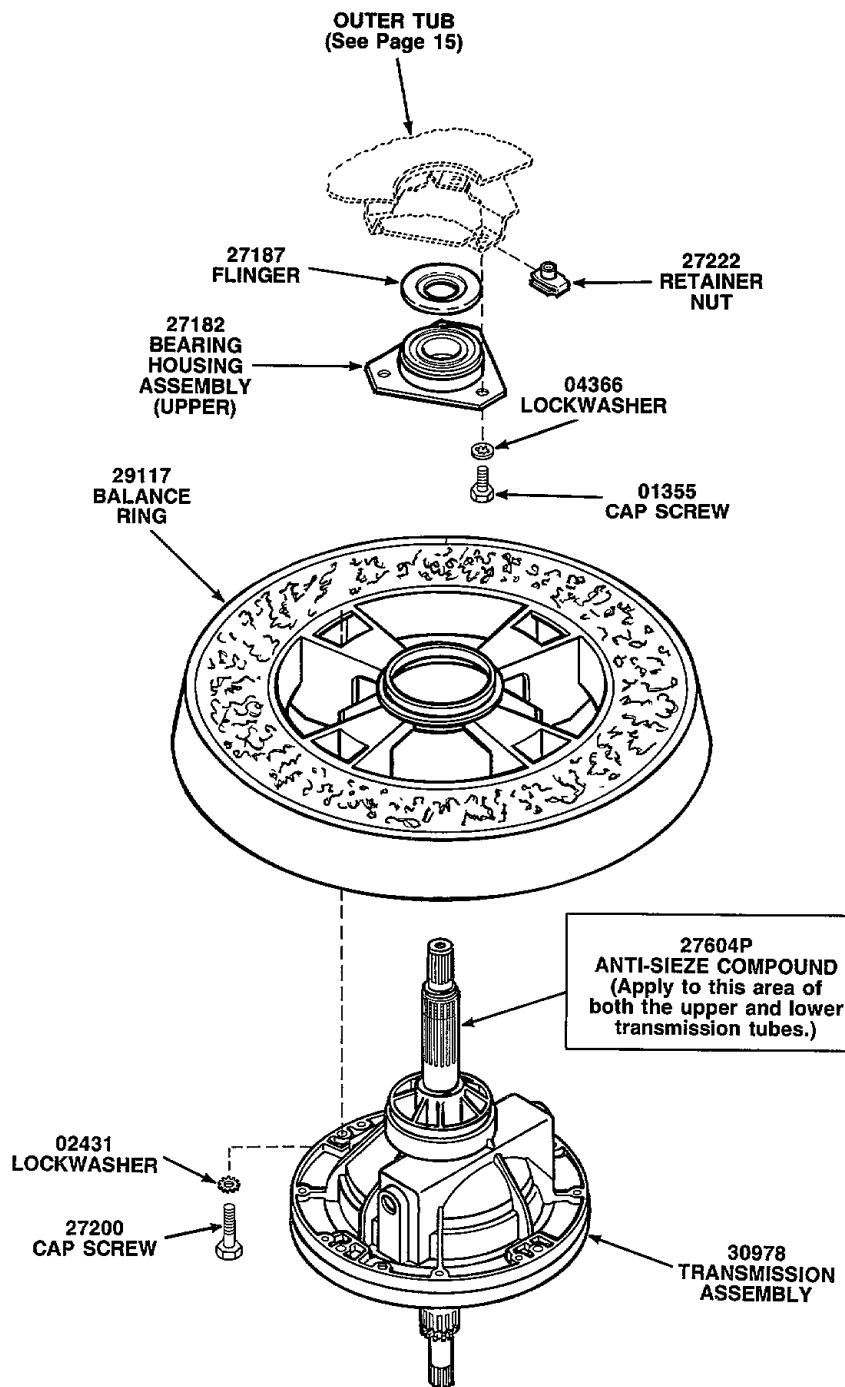

**TRANSMISSION ASSEMBLY AND BALANCE RING
(Short Post Models)**

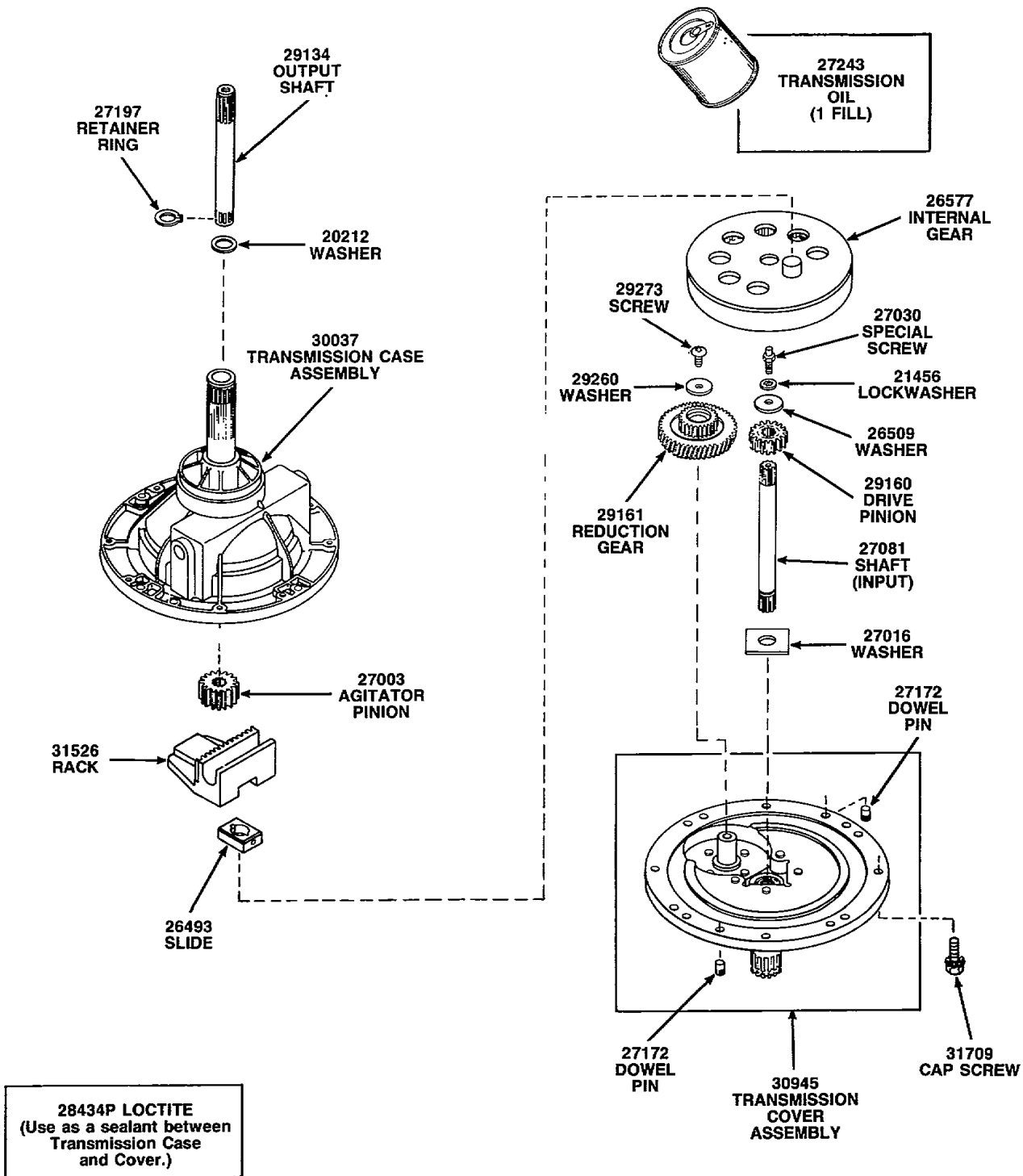

COMPONENTS FOR 30978 TRANSMISSION ASSEMBLY
(Short Post Models)

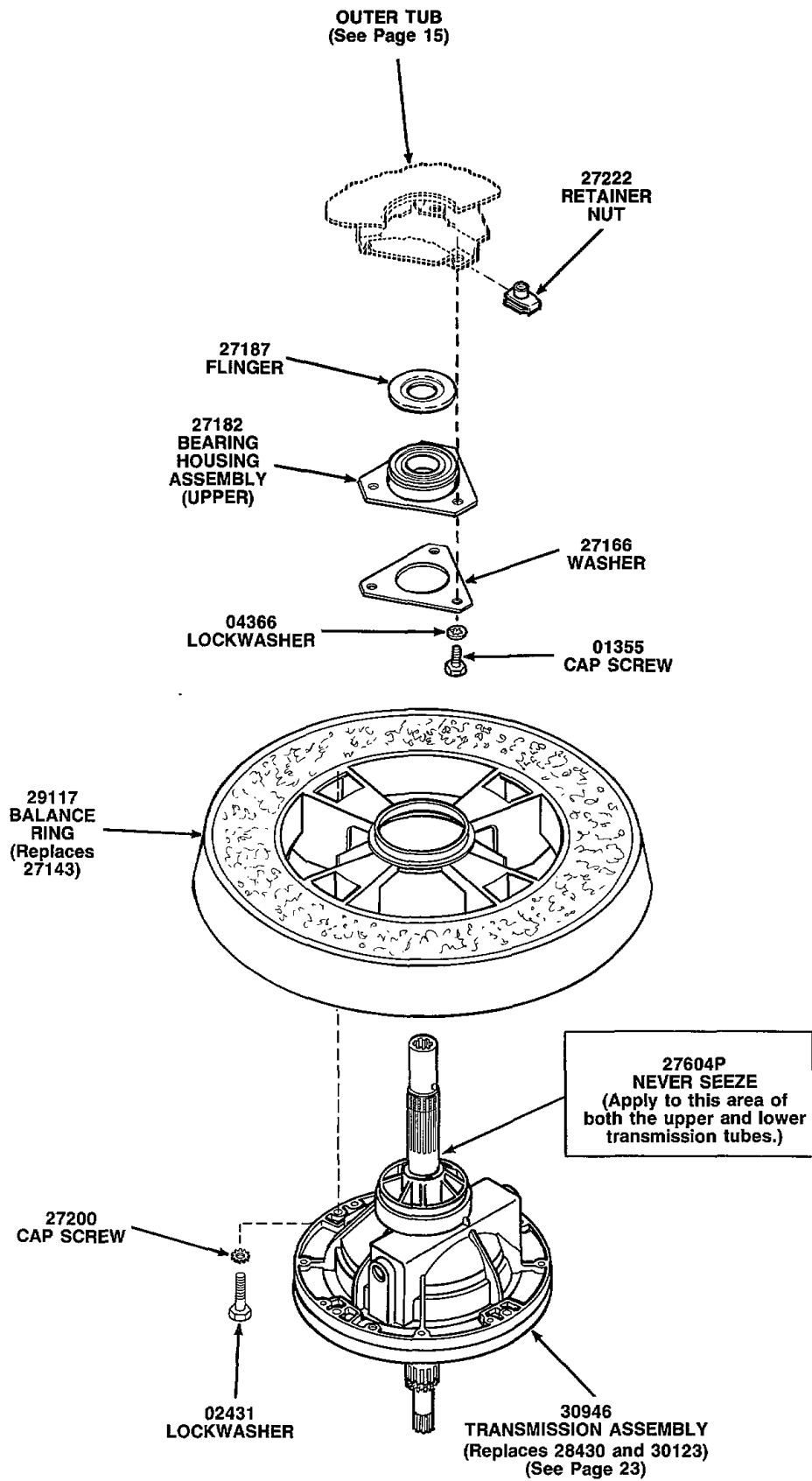

TRANSMISSION ASSEMBLY AND BALANCE RING
(Long Post Models)

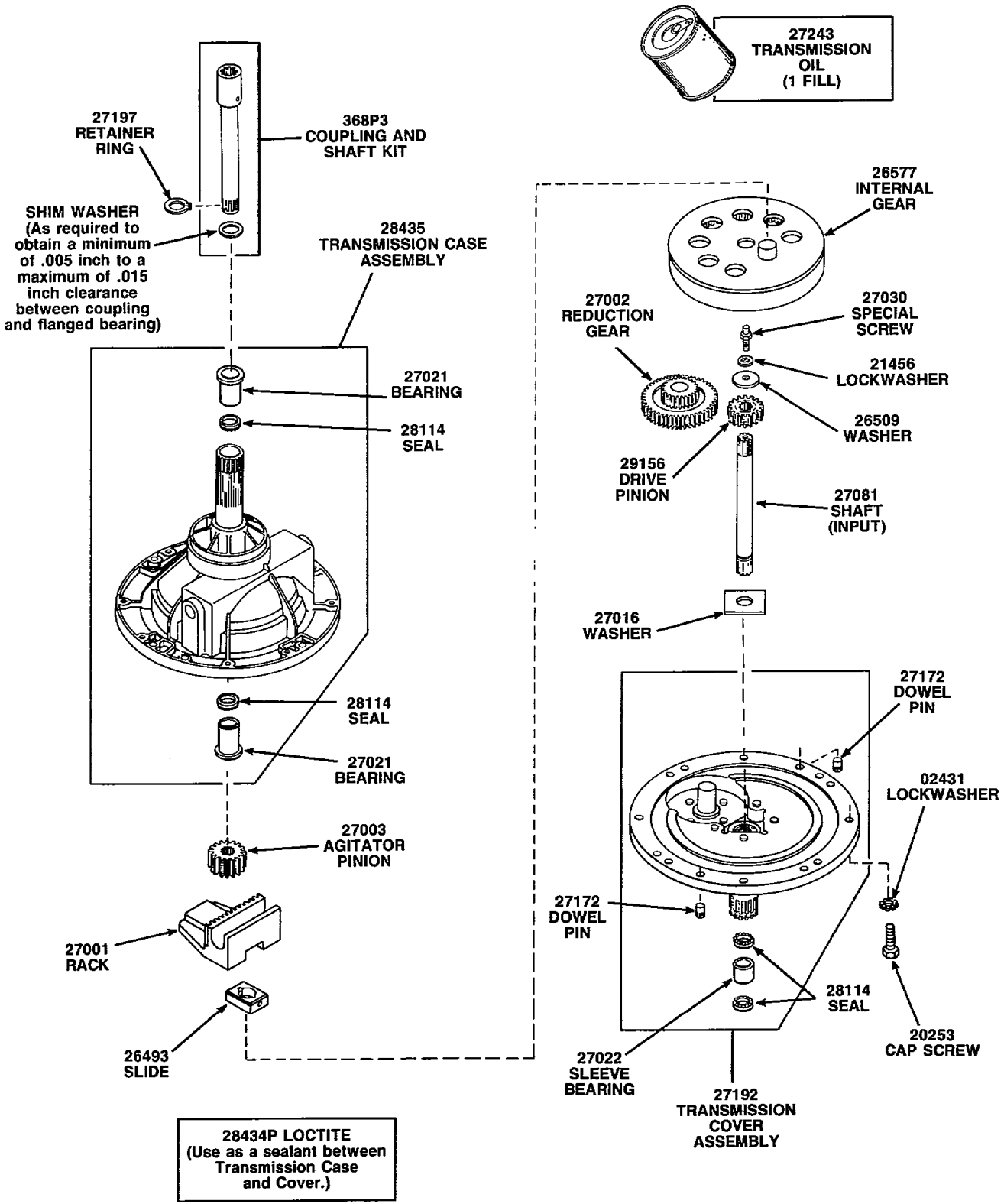

**COMPONENTS FOR 28430 TRANSMISSION ASSEMBLY
(Through Serial No. 1M295983)
(Long Post Models)**

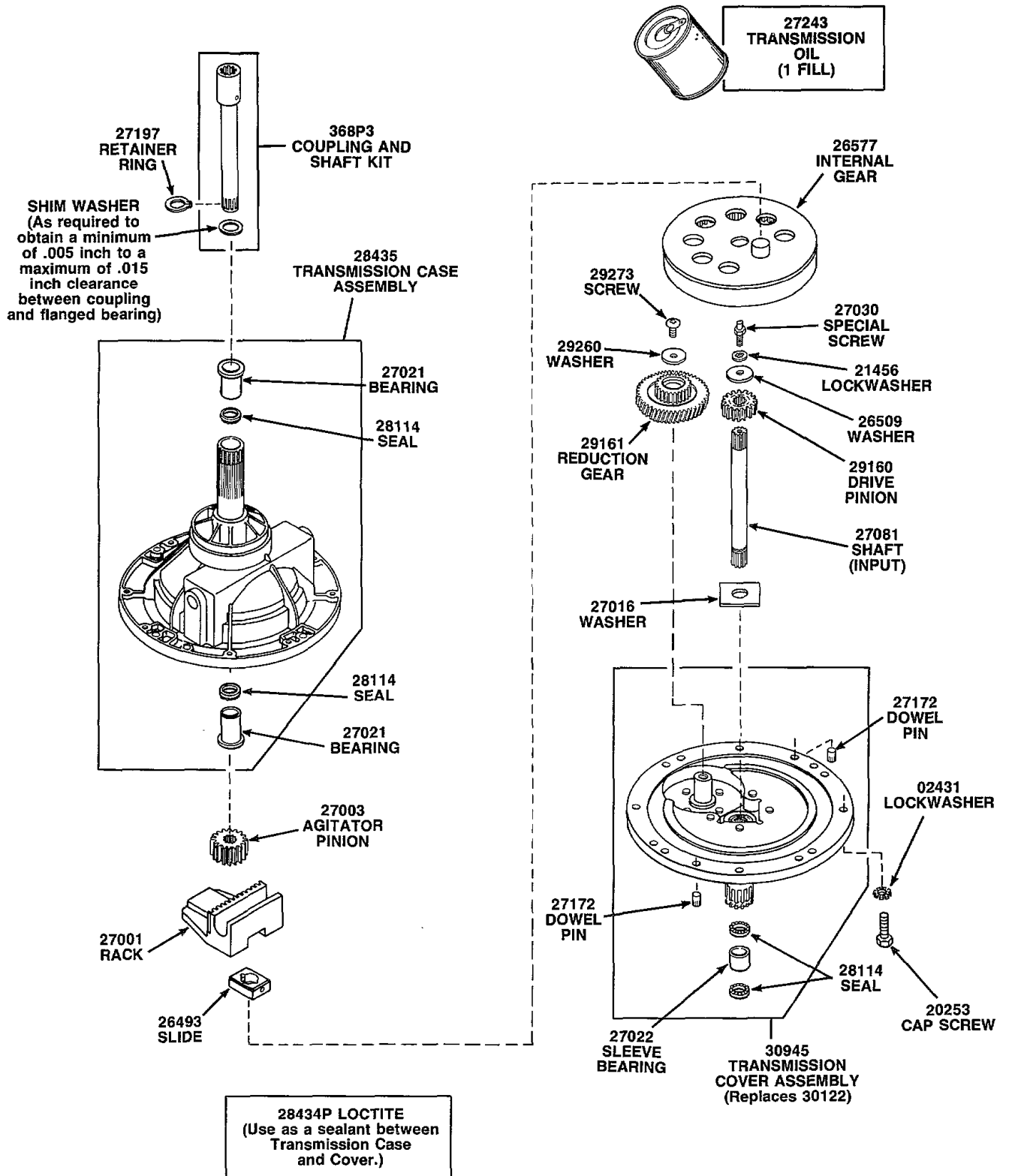

COMPONENTS FOR 30123 and 30946 TRANSMISSION ASSEMBLIES
(Starting Serial No. 1M295984)
(Long Post Models)

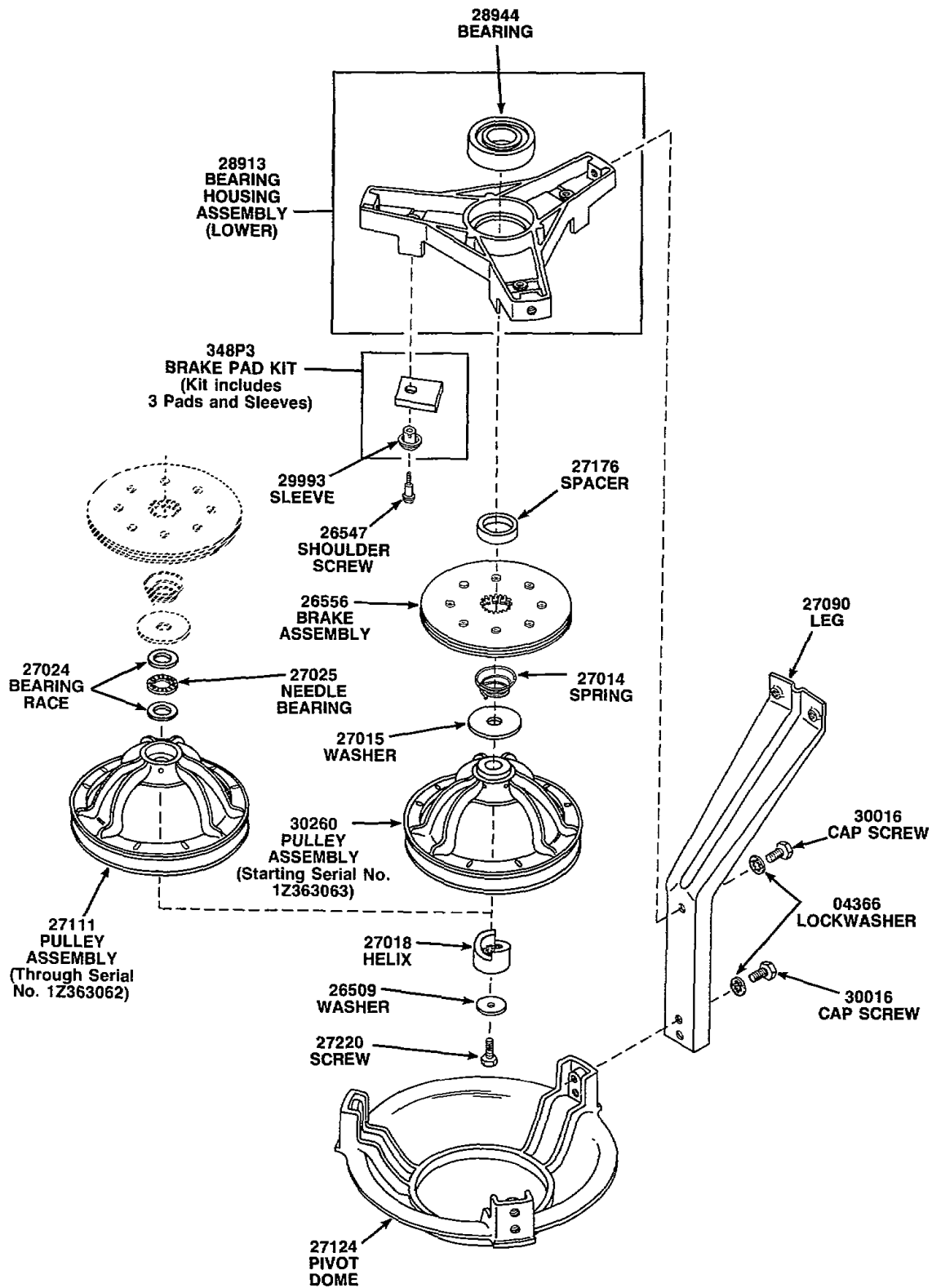

BEARING HOUSING, BRAKE, PULLEY AND PIVOT DOME

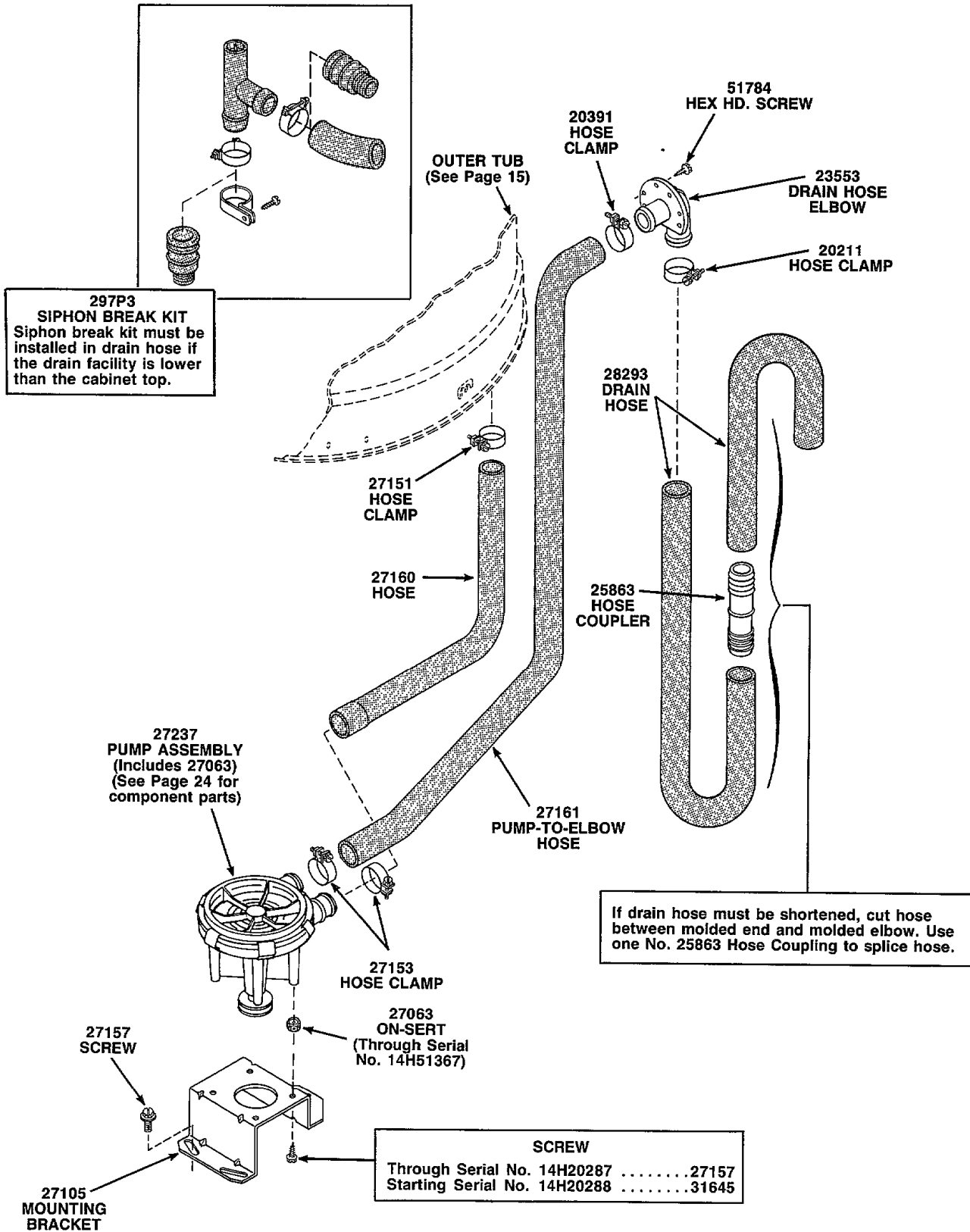

PUMP ASSEMBLY, BRACKET, HOSES AND SIPHON BREAK KIT

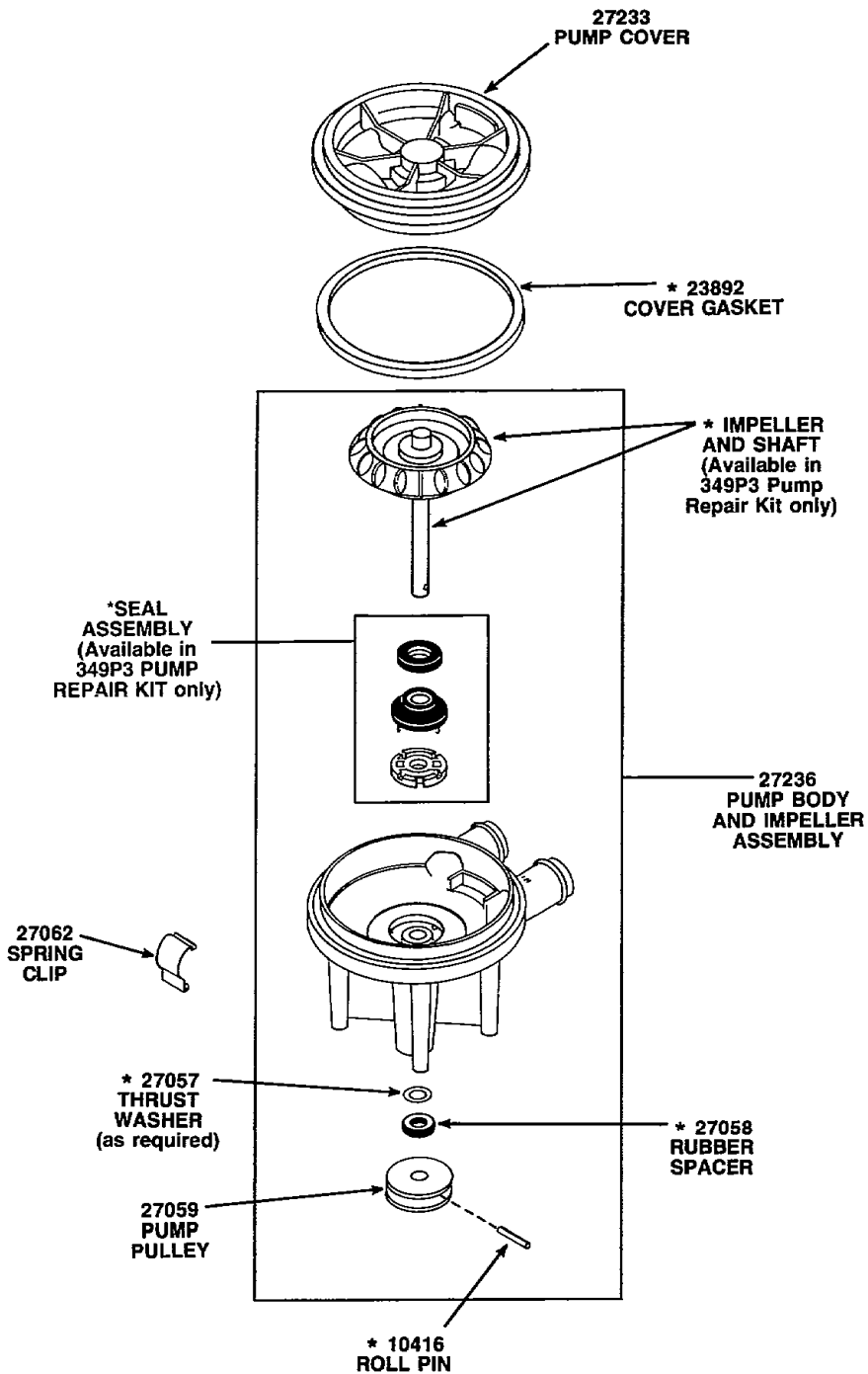

* 349P3 PUMP REPAIR KIT
(Includes all parts marked
with an asterisk.)

PUMP ASSEMBLY

*Add Suffix Letter To Part Number To Designate Color.
H Harvest Gold **L** Almond
W New White (Starting Serial No. 14G35561)
S Old White (Through Serial No. 14G35560)

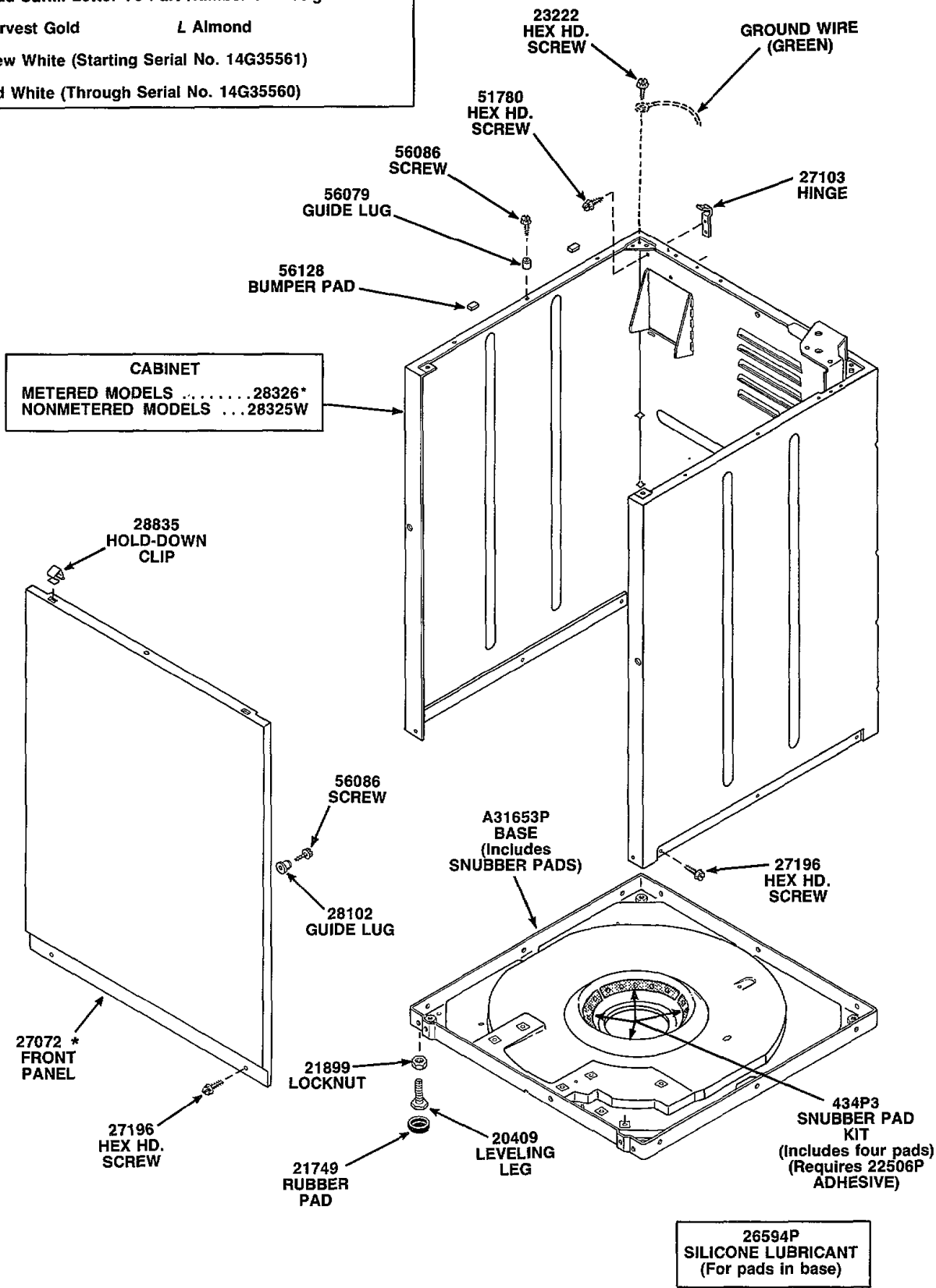

FRONT PANEL, CABINET AND BASE

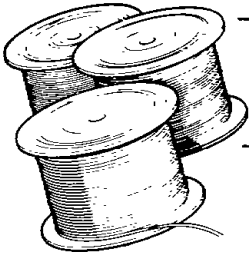

20680 18 GAUGE WIRE PER FOOT (SPECIFY COLOR)

ORDER BY THE FOOT. ALWAYS SPECIFY COLOR CODE REQUIRED. SEE WIRING DIAGRAM FOR CORRECT COLOR CODE.

INDIVIDUAL WIRES NOT SERVICED SEPARATELY. ORDER COMPLETE HARNESS OR ORDER WIRE BY THE FOOT AND NECESSARY CONNECTORS AND TERMINALS AS REQUIRED. IT IS RECOMMENDED THAT WHENEVER APPLYING TERMINALS TO WIRES THAT THE TERMINAL BE SOLDERED TO THE WIRE.

MODEL NUMBERS	BASE HARNESS	TIMER HARNESS	HOOD HARNESS	LID SWITCH HARNESS	MOTOR WIRE HARNESS
WA4710 and WA4711	28146	28217	29662	27873	28132
WA4950, WA4951 WA4960 and WA4961	28146	29279	29280	29283	28132
WA4720 and WA4721	28143	28216	29663	27873	28131
WA4970, WA4971, WA4980 and WA4981	28143	29281	29282	28131	

24176 MOLEX TERMINAL (Used for one or two wire application)

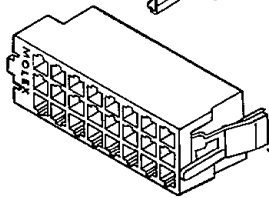

24175 MOLEX HOUSING

00183 AMP TERMINAL (TWO WIRE)

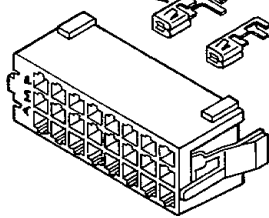

28856 AMP HOUSING

00180 AMP TERMINAL (ONE WIRE)

03673 NUT

03815 LOCKWASHER

00116 TERMINAL (MALE)

20267 ROUND HD. SCREW

22660 POWER CORD AND PLUG

TERMINAL BLOCK
26301 - 1 CIRCUIT
26708 - 6 CIRCUIT
26163 - 9 CIRCUIT

TERMINAL BLOCK
26302 - 1 CIRCUIT
23041 - 6 CIRCUIT
23033 - 9 CIRCUIT

00117 TERMINAL (FEMALE)

55881 WIRE TIE

51291 WIRE CLIP

00119 SPADE TERMINAL (LARGE SPADE)

00120 RIGHT ANGLE FLAG TERMINAL

29673 DOUBLE CONNECTOR

21091 CONNECTOR

00126 EYELET TERMINAL (1/4" RING)

00112 SPADE TERMINAL (SMALL SPADE)

00110 EYELET TERMINAL (SMALL SHANK)

70210 PLASTIC INSULATOR

00161 GROUND CLIP

POWER CORD, WIRE AND TERMINALS

Special Tools

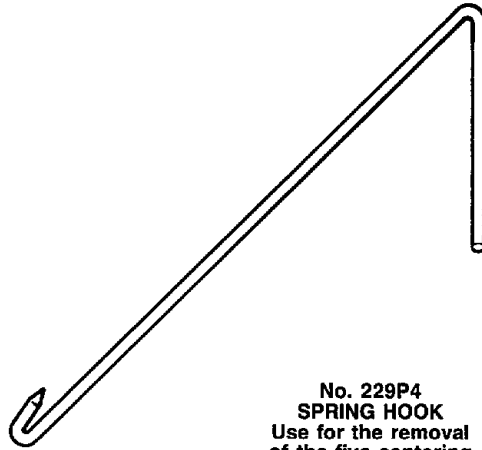

**No. 229P4
SPRING HOOK**
Use for the removal
of the five centering
springs from the outer tub.

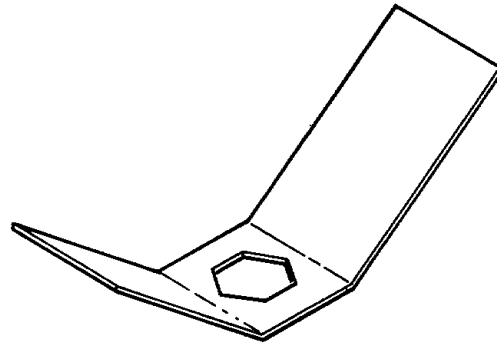

**No. 237P4
HEX WRENCH**
Use to remove hex
locknut from washtub hub.



**No. 242P4
BRAKE SPRING
INSTALLER**
Use to install
brake spring.

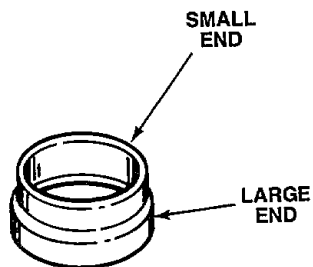

**No. 241P4
SEAL INSTALLER**
Use to install
No. 356P3
Washer Seal Kit
(Long Post Models Only)

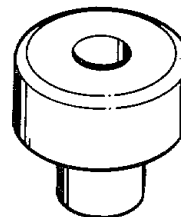

**No. 230P4
GUIDE SPINDLE**
Use for the removal of the
hub from the transmission.
(Long Post Models Only)

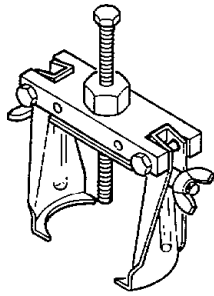

**No. 253P4
BELL TOOL**
Use for the removal and
installation of drive bell
to transmission shaft.
(Short Post Models Only)

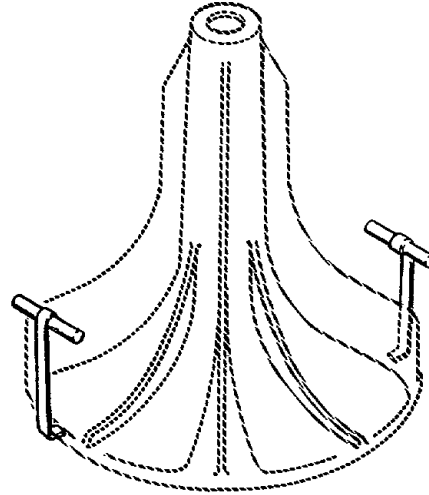

**No. 254P4
AGITATOR HOOKS**
(Set of two)
Use to remove agitator
from drive bell by hand.
(Short Post Models Only)

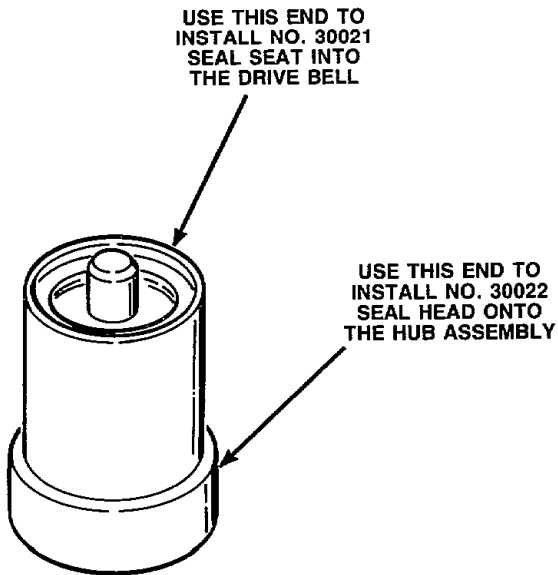

**No. 255P4
SEAL TOOL**
Use to install the seal seat
and the seal head.
(Short Post Models Only)

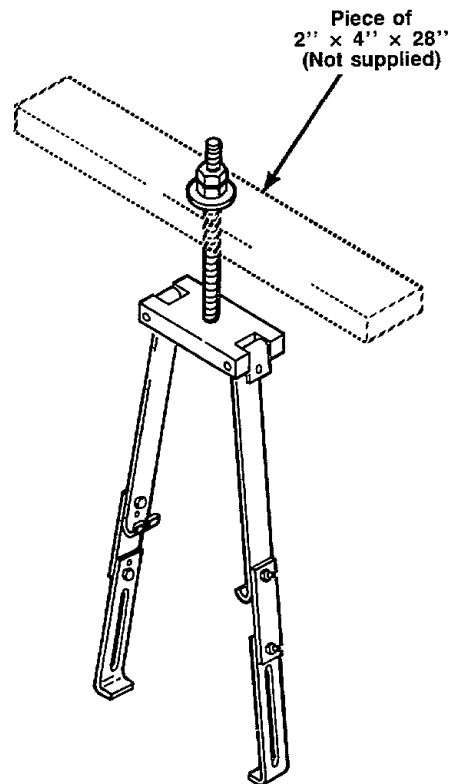

**No. 256P4
AGITATOR PULLER**
Use to remove agitator
from drive bell.
(Short Post Models Only)

SECTION II

Service Procedures

⚠ WARNING

Disconnect power cord and close water supply valves before servicing washer.

IMPORTANT: When reference is made to directions (right or left) in this manual, it is from the operator's position facing the front of the washer.

1. CONTROL PANEL (Refer to Figure 1)

- a. Remove two control panel attaching screws and lift assembly off panel support.

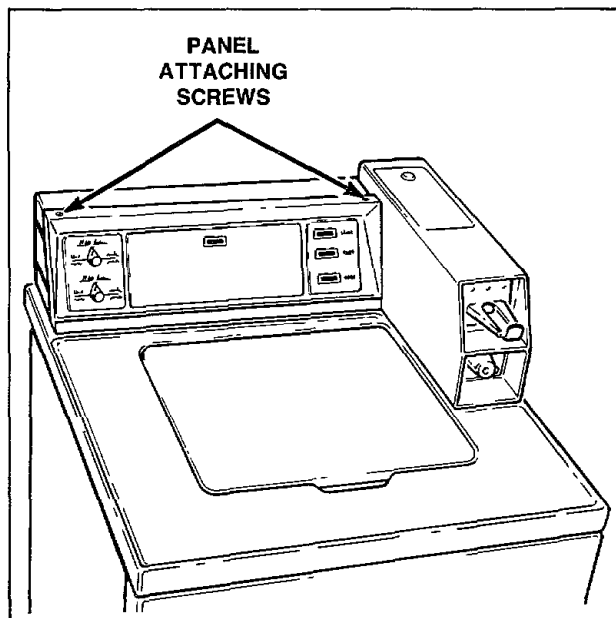

Figure 1

2. SPEED OR WASH TEMPERATURE SWITCH (Refer to Figure 2)

- a. Remove two control panel attaching screws and lift assembly off panel support.
- b. Loosen setscrew holding switch knob to switch shaft.
- c. Remove knurled nut holding switch to control panel.

NOTE: Lockwasher must be between switch and control panel when installing switch.

- d. Disconnect wires from switch.

NOTE: Refer to appropriate wiring diagram when rewiring switch.

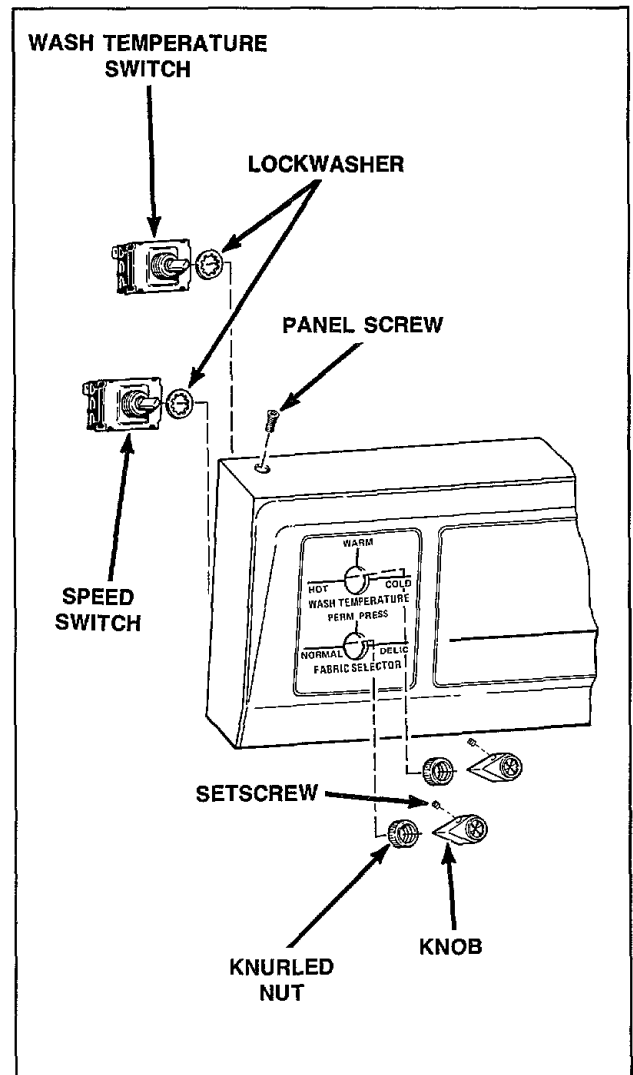

Figure 2

3. INDICATOR LIGHTS - IN USE, RINSE, SPIN OR UNBALANCED LOAD

- a. Remove two control panel attaching screws and lift assembly off panel support.
- b. Disconnect wires from light.

NOTE: Refer to appropriate wiring diagram when rewiring light.

- c. Squeeze locking tabs together and push light out through front of panel.

IMPORTANT: Pressing on center of lens when installing INDICATOR LIGHT may break lens. Insert light into control panel by pressing firmly against trim.

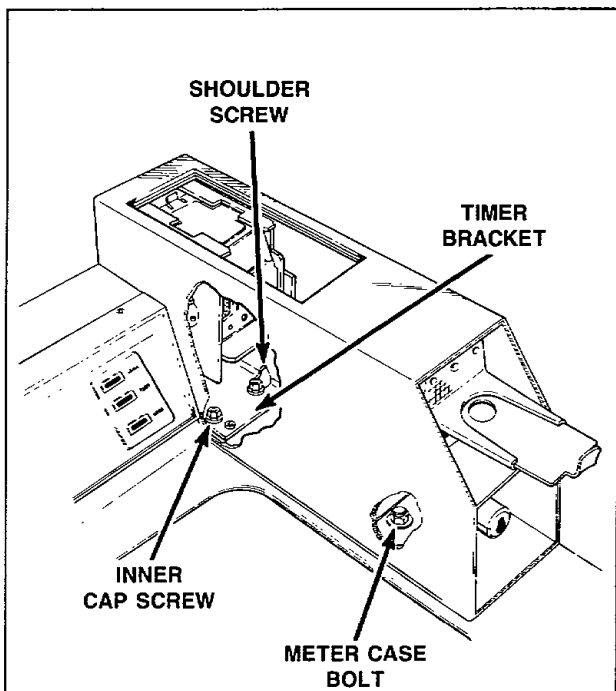

Figure 3

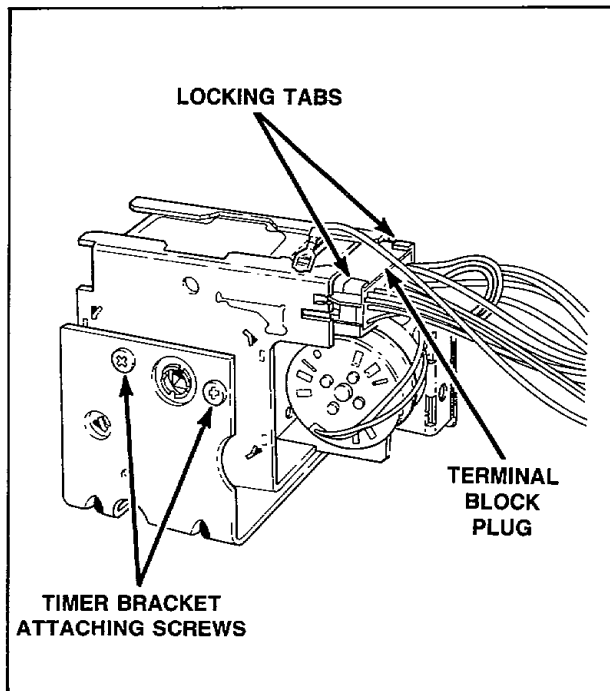

Figure 4

WARNING

Disconnect power cord and close water supply valves before servicing washer.

4. TIMER ASSEMBLY – Metered Models

- a. Unlock and remove service door.
- b. Remove the inner timer bracket cap screw, *Figure 3*.
- c. Slide timer and bracket to the left to disengage bracket from shoulder screw, then lift timer and bracket up and out of meter case through service door opening as far as wires will permit.
- d. Disengage wire harness terminal block plug from timer by pressing in on the movable locking tabs (located on each side of terminal block plug), *Figure 4*. Then pull the terminal block plug away from timer.

IMPORTANT: To avoid an open circuit, **DO NOT** pull on the terminal block wires when removing block from timer as this could damage the wires or terminal crimpings.

NOTE: To avoid timer damage, do not allow timer to be struck on the corners, edges of frame or on the timer shaft.

- e. Remove two screws holding timer to bracket, *Figure 4*.
- f. Loosen setscrew holding clutch to timer shaft. *Figure 5*.

NOTE: When installing clutch, be sure clutch moves freely after setscrews are tightened.

IMPORTANT: Be careful not to dislodge or damage the two timer motor lead wires while handling timer.

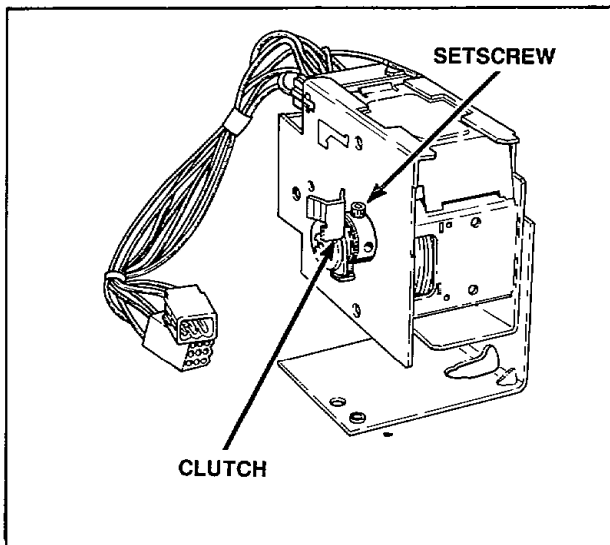

Figure 5

5. TIMER ASSEMBLY – Nonmetered Models (Refer to Figure 6)

- a. Loosen two setscrews holding timer knob to timer shaft.
- b. Remove four screws and lockwashers holding timer and plate to timer case.

NOTE: When reinstalling timer and plate, lockwashers must be between heads of screws and timer plate.

- c. Pull timer and plate out as far as wires will permit.

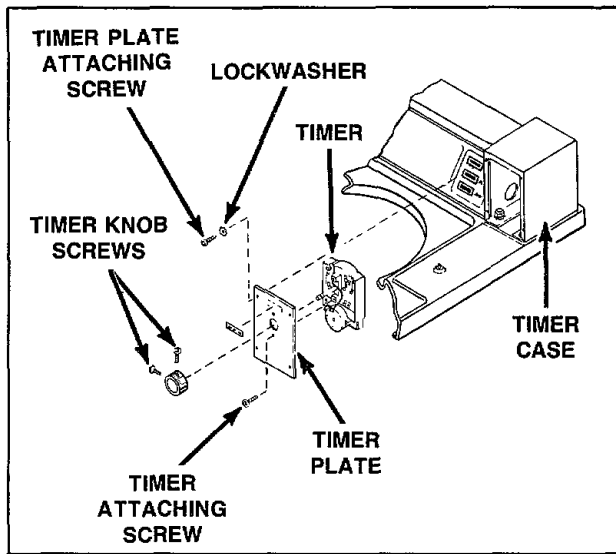

Figure 6

NOTE: Disconnect ground wire from rear of timer.

- d. Pull wire harness and blocks through into timer housing, then disconnect timer harness from control hood harness at quick disconnect block.
- e. Remove two screws holding timer to timer plate.
- f. Disconnect wires from timer.

NOTE: Refer to appropriate wiring diagram when rewiring timer.

⚠ WARNING

Disconnect power cord and close water supply valves before servicing washer.

6. METER CASE

- a. Unlock and remove service door.
- b. Remove the inner timer bracket cap screw, *Figure 3*.
- c. Slide timer and bracket to the left to disengage bracket from shoulder screw.
- d. Remove two control panel attaching screws, *Figure 1*, and lift assembly off panel support.
- e. Disconnect timer harness from control hood harness at disconnect blocks, *Figure 7*.
- f. Remove timer, bracket and harness out through service door opening.
- g. Remove cap screw, lockwashers and nut holding meter case to end of control hood, *Figure 7*.
- h. Remove coin drawer, *Figure 7*.
- i. Open loading door, hold hand under front meter case bolt, *Figure 3*. Remove nut and lockwasher.
- j. Remove the shoulder screw from inside meter case.

NOTE: When installing meter case, shoulder screw must be installed in the outer hole, *Figure 3*, to enable the timer bracket to slide under the screw head.

- k. Carefully remove meter case from cabinet top.

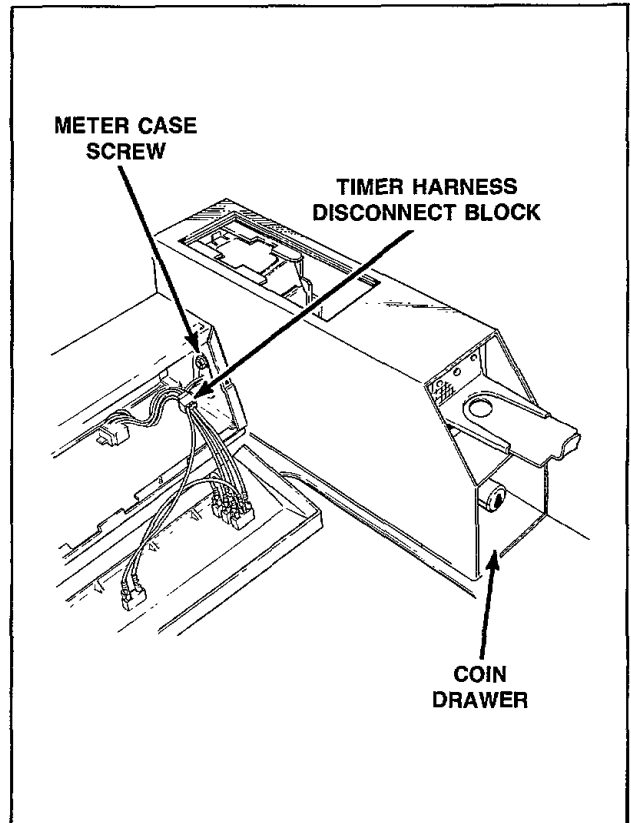

Figure 7

7. TIMER CASE

- a. Remove timer assembly, *paragraph 5*.
- b. Remove two control panel attaching screws and lift assembly off panel support, *Figure 1*.
- c. Remove cap screw, lockwashers and nut holding timer case to control hood, *Figure 8*.
- d. Remove two screws from bottom edge of front panel.

(continued)

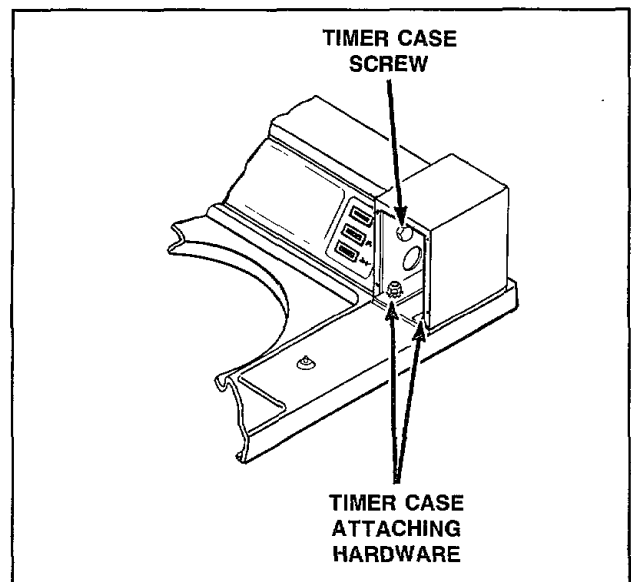

Figure 8

- e. Pull bottom of panel away from washer until hold-down clips (located on top flange of panel) disengage from slots in cabinet top, *Figure 9*.
- f. Remove two cabinet top hold-down screws, *Figure 9*.
- g. Tape loading door closed and lift cabinet top to a vertical position.
- h. Remove carriage bolts, washer, lockwashers, and nuts holding timer case to cabinet top.
- i. Support timer case and remove screw and fiber washer holding rear of case to cabinet top.

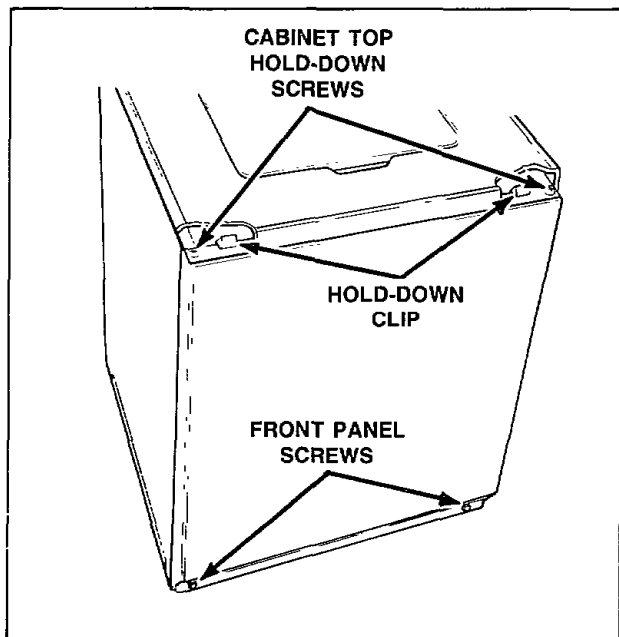

Figure 9

8. PRESSURE SWITCH

- a. Remove control panel assembly screws and lift off panel support.
- b. Remove two screws holding switch to mounting bracket.
- c. Pull switch out of control hood far enough to disconnect pressure hose and wires from switch.

NOTE: Refer to appropriate wiring diagram when rewiring switch.

IMPORTANT: When installing pressure switch, blow air into hose before connecting hose to switch to remove any moisture that may have accumulated in the hose.

9. DRAIN HOSE ELBOW (Refer to *Figure 10*)

- a. Loosen hose clamp and remove drain hose from elbow.
- b. Remove screws holding elbow to rear of washer cabinet.

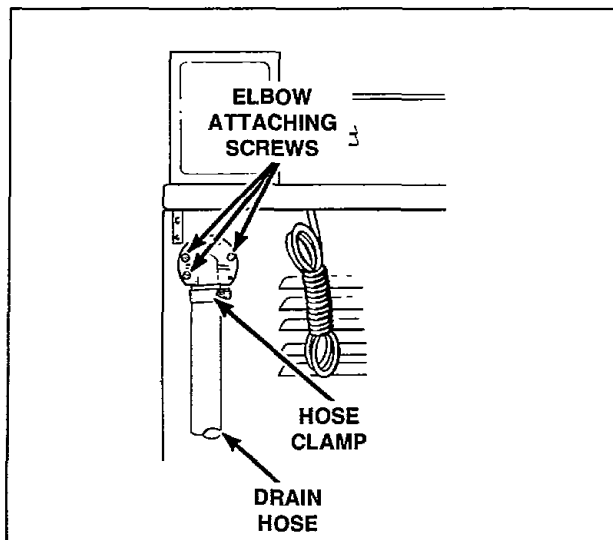

Figure 10

- c. Pull elbow out through opening in cabinet far enough to permit loosening inner clamp, then remove elbow from inner hose.

NOTE: When installing elbow on inner hose, **DO NOT** allow hose inside of washer to twist! Direct elbow toward drain receptacle and secure elbow to washer cabinet.

10. LOADING DOOR (Refer to *Figure 11*)

- a. Depress tab on either hinge, then slide hinge out of loading door and bushing in cabinet top.
- b. Tilt loading door slightly and slide door and hinge out of opposite bushing.

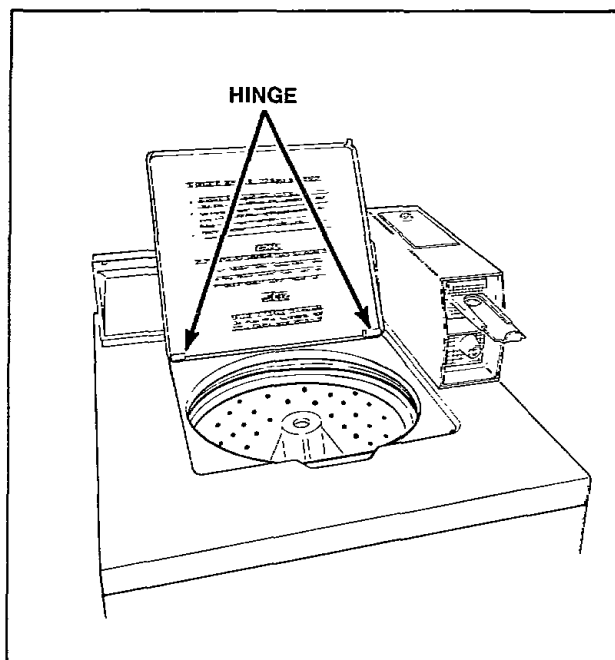

Figure 11

11. AGITATOR (Short Post Models)

- a. Open loading door.
- b. To remove the agitator by hand, place two agitator hooks, No. 254P4, under the bottom edge of the agitator, *Figure 12*.

IMPORTANT: Hooks should be positioned 180° of each other, and must be placed under the agitator fin for greater stability. If hooks are placed between the fin area, damage to the agitator may occur.

- c. Using a rocking motion (back and forth) carefully lift the agitator off the drive bell.

NOTE: If the agitator cannot be removed using the agitator hooks, then the agitator will have to be removed using No. 256P4 Agitator Puller Tool, Page 28. This tool can be used by following the instructions supplied with the tool.

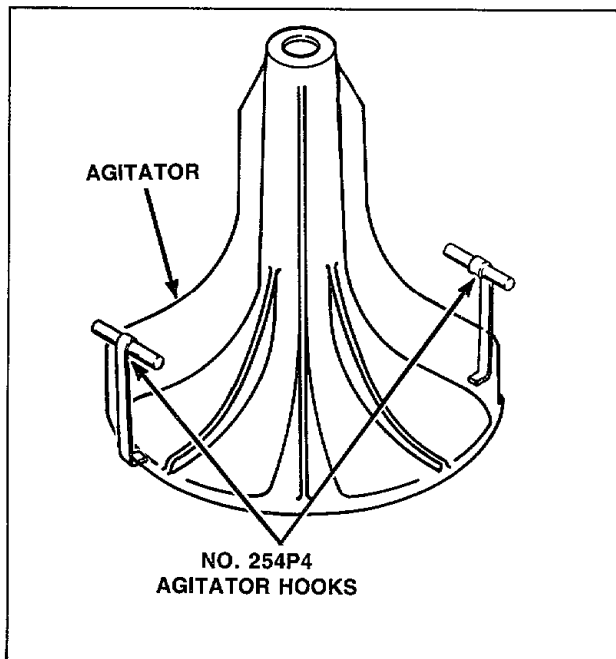

Figure 12

12. AGITATOR DRIVE BELL AND SEAL SEAT ASSEMBLY (Short Post Models)

⚠ WARNING

To reduce the risk of electric shock or injury to persons, disconnect washer power cord before servicing the washer. If water is present in the washtub, spin and pump out before attempting to remove the drive bell and seal seat assembly.

- a. Open loading door.
- b. To remove the agitator by hand, place two agitator hooks, No. 254P4, under the bottom edge of the agitator, *Figure 12*.

IMPORTANT: Hooks should be positioned 180° of each other, and must be placed under the agitator fin for greater stability. If hooks are placed between the fin area, damage to the agitator may occur.

- c. Using a rocking motion (back and forth) carefully lift the agitator off the drive bell.

NOTE: If the agitator cannot be removed using the agitator hooks, then the agitator will have to be removed using No. 256P4 Agitator Puller Tool. This tool can be used by following instructions supplied with the tool.

- d. Remove the screw and "O" ring washer from the top side of the drive bell.

NOTE: To remove the drive bell from the transmission shaft will require using the No. 253P4 Drive Bell Tool.

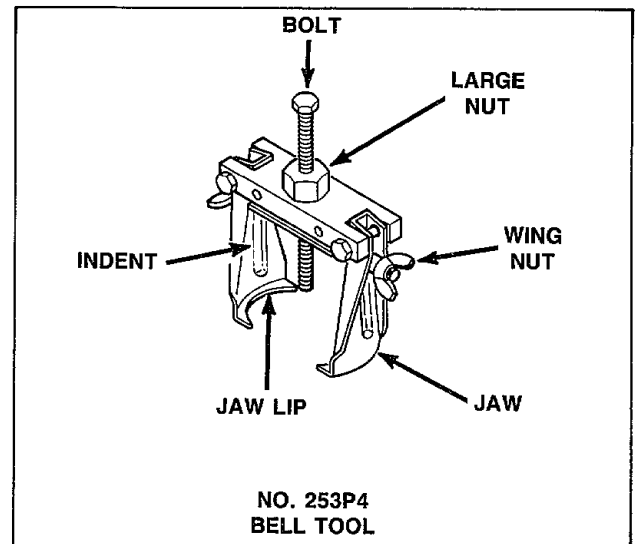

Figure 13

- e. Back the bolt out of tool approximately three quarters of the way.
- f. Place the tool over the bell making sure the indent on the jaw lines up with the wide slots on the bell, *Figure 14*.
- g. Screw the bolt down through the hole in top of bell until bolt bottoms out in the hole in the shaft.
- h. Place the lip of each jaw under the bottom edge of the drive bell, making sure the indent on the jaw lines up with the wide slots on the bell. Then tighten the two wing nuts to hold the jaws firmly against the drive bell, *Figure 14*.

(continued)

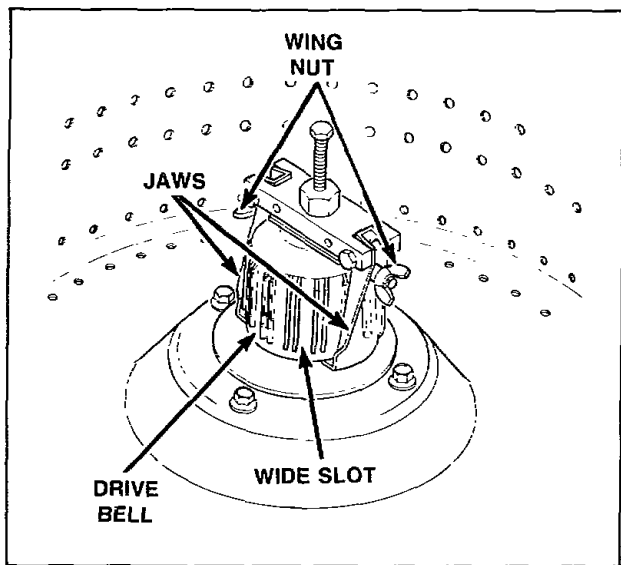

Figure 14

- i. Use an adjustable wrench and turn the large nut on the tool **COUNTERCLOCKWISE** to pull the drive bell from the transmission shaft, *Figure 15*.

IMPORTANT: If the large nut is turned clockwise when pulling the drive bell, you will twist off the 1/4 inch bolt.

- j. Turn the 1/4 inch Bolt, Part No. 32286, out of the transmission shaft and remove tool and drive bell from washer.
- k. Loosen the two wing nuts and remove the drive bell from the tool.
- l. Carefully pry the old seal out of the drive bell and clean any foreign materials from the bell.

IMPORTANT: Both the seal seat and the seal head must be replaced together in pairs. **DO NOT** replace only one of the two.

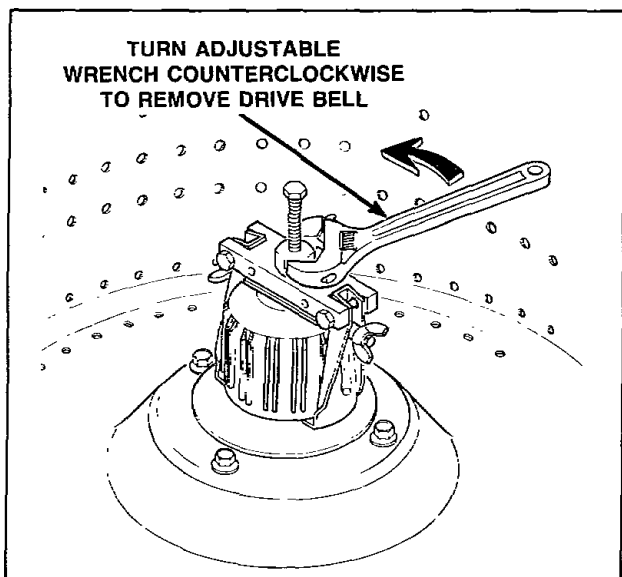

Figure 15

- m. Install the new seal into the drive bell using the small end of the No. 255P4 Seal Tool.
- n. Remove the seal head from the hub and clean any foreign material from the hub seal mounting area.
- o. Place the new seal head on hub and carefully push the seal head into position using the large end of No. 255P4 Seal Tool. Make sure the seal is pressed down against the shoulder on the hub.

NOTE: Soapy water will aid in the assembly of the seal onto the hub.

IMPORTANT: Make sure the seal is pressed down against the shoulder on the hub.

⚠ WARNING

DO NOT apply any type of lubricants to the sealing surfaces of either the seal seat or seal head as you will damage the seals.

TO REINSTALL DRIVE BELL

- a. Position drive bell over transmission shaft. Rotate drive bell until splines in drive bell line up with splines on transmission shaft.
- b. Place the No. 253P4 Bell Tool over top of bell. Screw bolt into transmission shaft until it bottoms out.

NOTE: It is not necessary to use the tool jaws on the drive bell during this operation.

- c. Use an adjustable wrench and turn the large nut on the tool **CLOCKWISE** to force the drive bell down onto transmission shaft until the bell bottoms out on the shaft.
- d. Turn the bolt out of the transmission shaft and remove the tool.
- e. Place the new No. 30853 "O" Ring Gasket onto the new No. 30852 Screw. Thread the new No. 30852 Screw down through the hole in the top of the drive bell and into the transmission shaft. **DO NOT** reuse the old screw and "O" ring gasket!

NOTE: Torque new No. 30852 Screw down between 45 to 55 inch pounds. Over torque will mushroom the plastic bell.

- f. Place agitator on top of drive bell. Slowly rotate the agitator until the fingers on the underside of agitator line up with the large slots on drive bell.
- g. A sharp blow on top of the agitator, with the palm of your hand, will force the agitator down onto the drive bell, allowing the fingers on the underside of the agitator to lock under the bottom edge of the drive bell.

NOTE: Do not push the agitator onto the drive bell any further than necessary.

13. AGITATOR POST ASSEMBLY (Long Post Models)

⚠ WARNING

If water is present in washtub, spin and pump out before removing agitator post assembly.

- a. Remove agitator hold-down cap and lift agitator out of washtub, *Figure 16*.
- b. Remove four cap screws holding agitator post assembly to washtub hub, *Figure 17*, then lift assembly out of washtub.

NOTE: Models equipped with gasket – Use a new gasket when installing agitator post. (Be sure all traces of old gasket are removed from the hub and agitator post.) Apply a small bead of sealant, No. 27615, to each of the sealing surfaces where the agitator post gasket will contact the hub. Carefully place new gasket, No. 27020, on hub. Be sure holes in gasket are aligned with bolt holes in hub.

Models equipped with Loctite – Be sure all traces of old loctite are removed from the hub and agitator post. Apply approximately a 1/16 inch diameter continuous bead of No. 28434P Loctite to the embossed surfaces of the agitator post, *Figure 18*.

- c. While tightening the four cap screws, tap lightly on the drive block to force splines on drive shaft into the coupling on the transmission assembly.

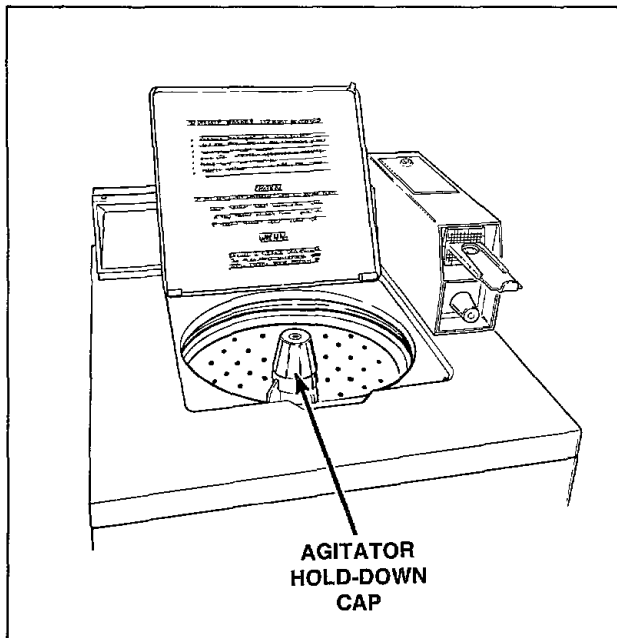

Figure 16

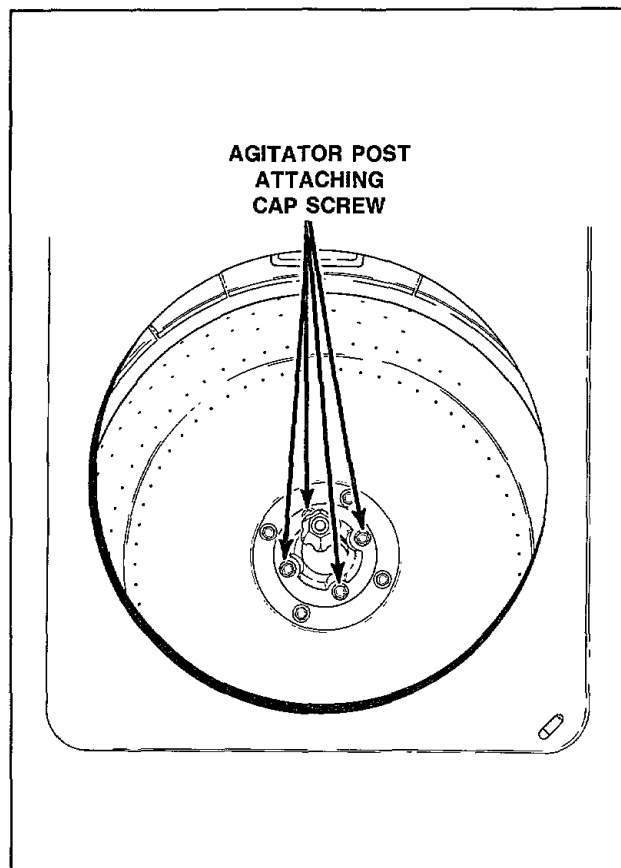

Figure 17

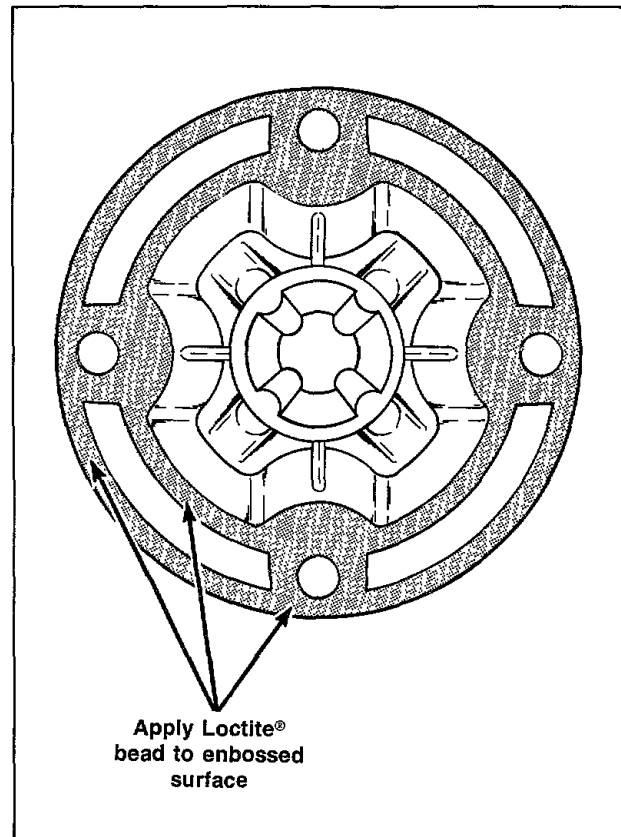

Figure 18

14. **AGITATOR DRIVE SHAFT** (Refer to Figure 19)
(Long Post Models)

- a. Remove agitator post assembly, *paragraph 13*.
- b. Remove retainer ring from bottom end of drive shaft, grasp agitator drive block and pull shaft out of agitator post.

IMPORTANT: Stainless steel washer must be between thrust bearing and fiber washer on agitator drive block when installing drive shaft.

CAUTION

Use caution when installing drive shaft in agitator post to prevent cutting seal lips with the splines on lower end of drive shaft.

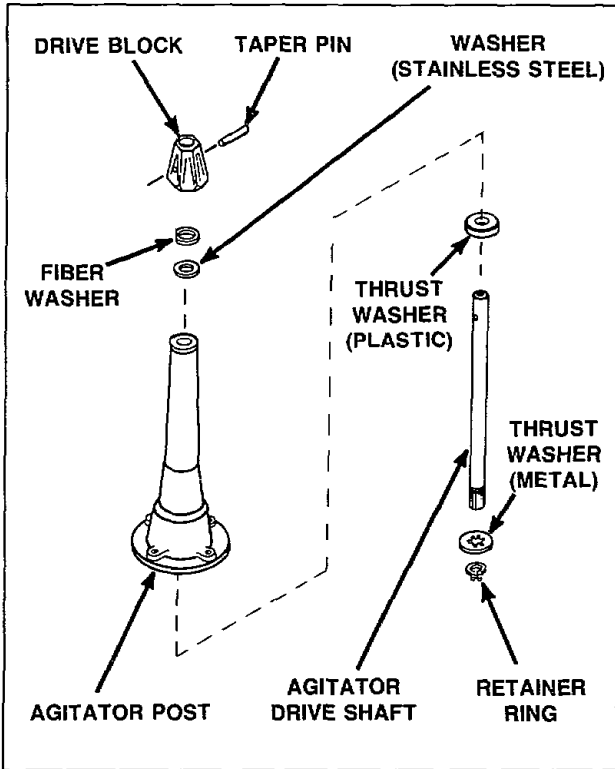

Figure 19

15. **FRONT PANEL** (Refer to Figure 20)

- a. Remove two screws from bottom edge of panel.
- b. Pull bottom of panel away from washer until hold-down clips (located on top flange of panel) disengage from slots in cabinet top.

Hold-Down Clips

Compress hold-down clips enough to remove from slots in top flange of panel.

Guide Lugs

Remove screws holding guide lugs to side flanges of front panel.

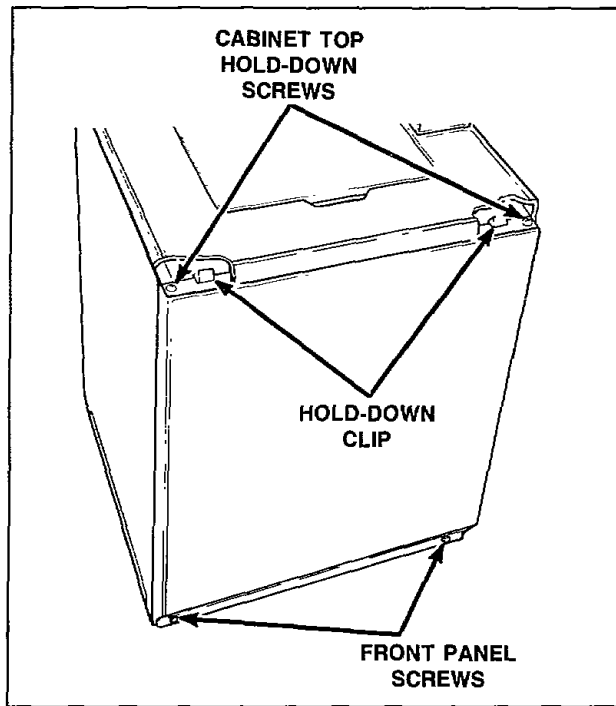

Figure 20

16. **PUMP BELT**

- a. Remove front panel, *paragraph 15*.
- b. Remove two front mounting screws and loosen the mounting screw holding pump and bracket to washer base, *Figure 21*, pivot entire assembly toward motor to loosen belt tension.
- c. Run belt off motor pulley, then remove belt from pump pulley.

NOTE: After installing pump belt, adjust belt, *paragraph 40*.

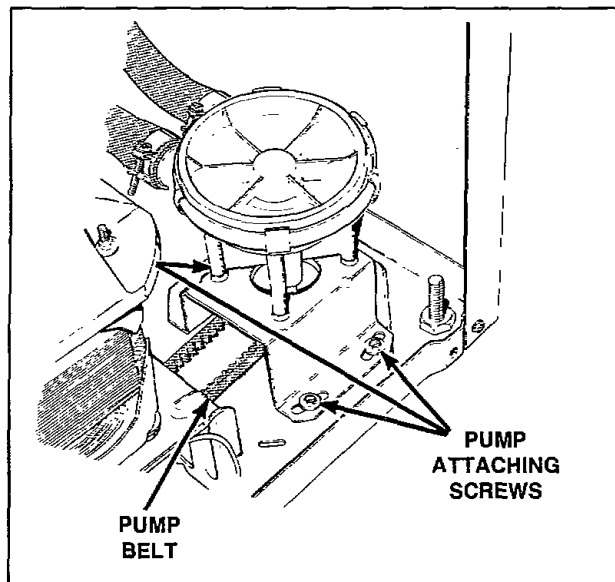

Figure 21

17. DRIVE BELT

- a. Remove front panel, *paragraph 15*.
- b. Remove two front mounting screws and loosen the rear mounting screw holding pump and bracket to washer base, *Figure 21*, pivot entire assembly toward motor to loosen belt tension.
- c. Reach in through front of motor mount and move idler lever to the left to release tension on belt.

IMPORTANT: Use caution when releasing the idler lever tension. If the idler spring is overstretched, it will affect the washer operation.

- d. While holding idler lever, reach in and around right side of motor and run belt off right side of large drive pulley, *Figure 22*.
- e. Remove belt from motor pulley and pull belt out through front of motor mount.

IMPORTANT: Drive belt **MUST** be replaced with belt No. 28808 (special clutch type belt) for proper washer operation.

TO INSTALL DRIVE BELT

NOTE: If the new belt is replacing a burned belt, the motor pulley "V" groove must be polished with a fine (320 grit) emery cloth to remove rubber residue. The residue will affect the washer spin operation.

- a. Push belt in through front of motor mount and place belt on motor pulley.
- b. Reach in and around right side of motor, starting with belt on right side of large drive pulley, run belt onto pulley.
- c. Reach in through front of motor mount and move idler lever to the left.

IMPORTANT: Do not overstretch idler spring as it will affect the washer operation.

- d. While holding idler lever, reach in and around right side of motor and place on idler pulley. **IDLER PULLEY MUST RIDE ON OUTSIDE OF BELT.**

NOTE: There is no belt adjustment after installing drive belt.

- e. Install pump belt, adjust belt per *paragraph 36*.

18. MOTOR AND MOUNTING BRACKET

- a. Remove front panel, *paragraph 15*.
- b. Disconnect motor wire harness plug from base wire harness receptacle.
- c. Remove pump belt, *paragraph 16*, then remove drive belt, *paragraph 17*.

NOTE: When installing belts, adjust pump belt, *paragraph 40*. There is no drive belt adjustment.

(continued)

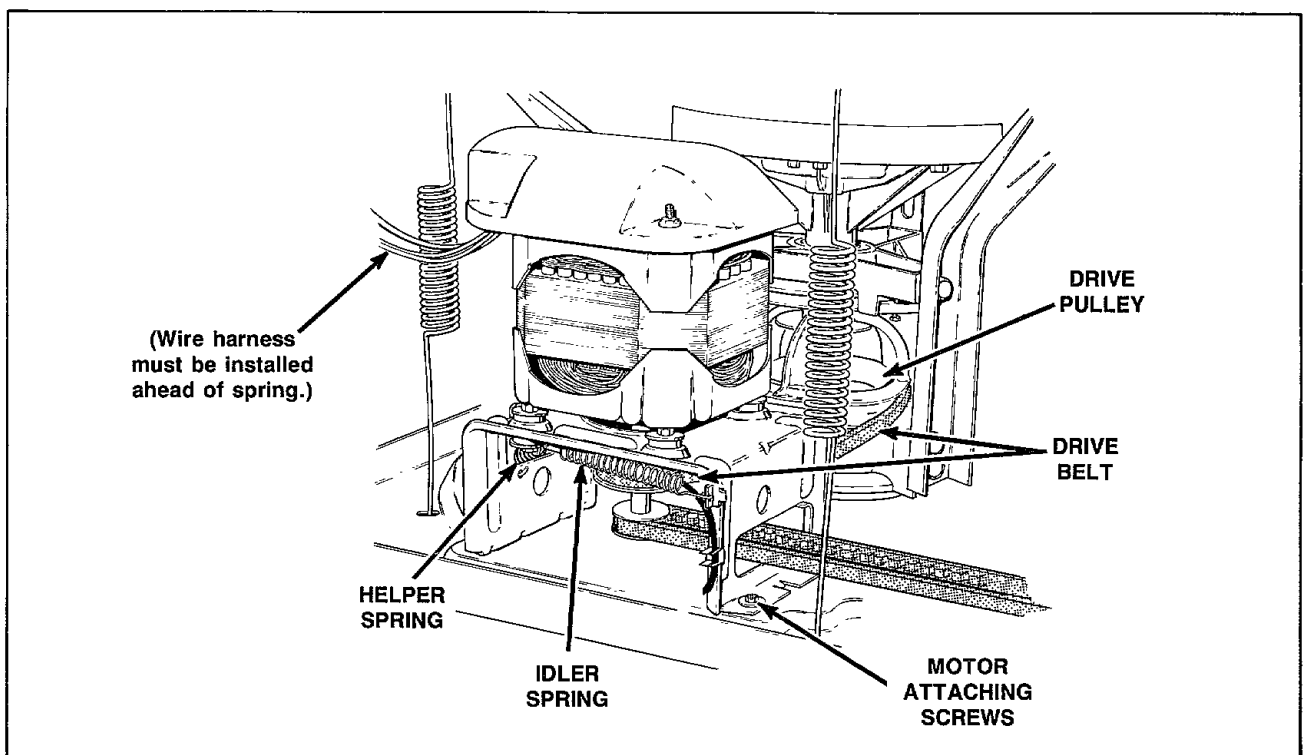

Figure 22

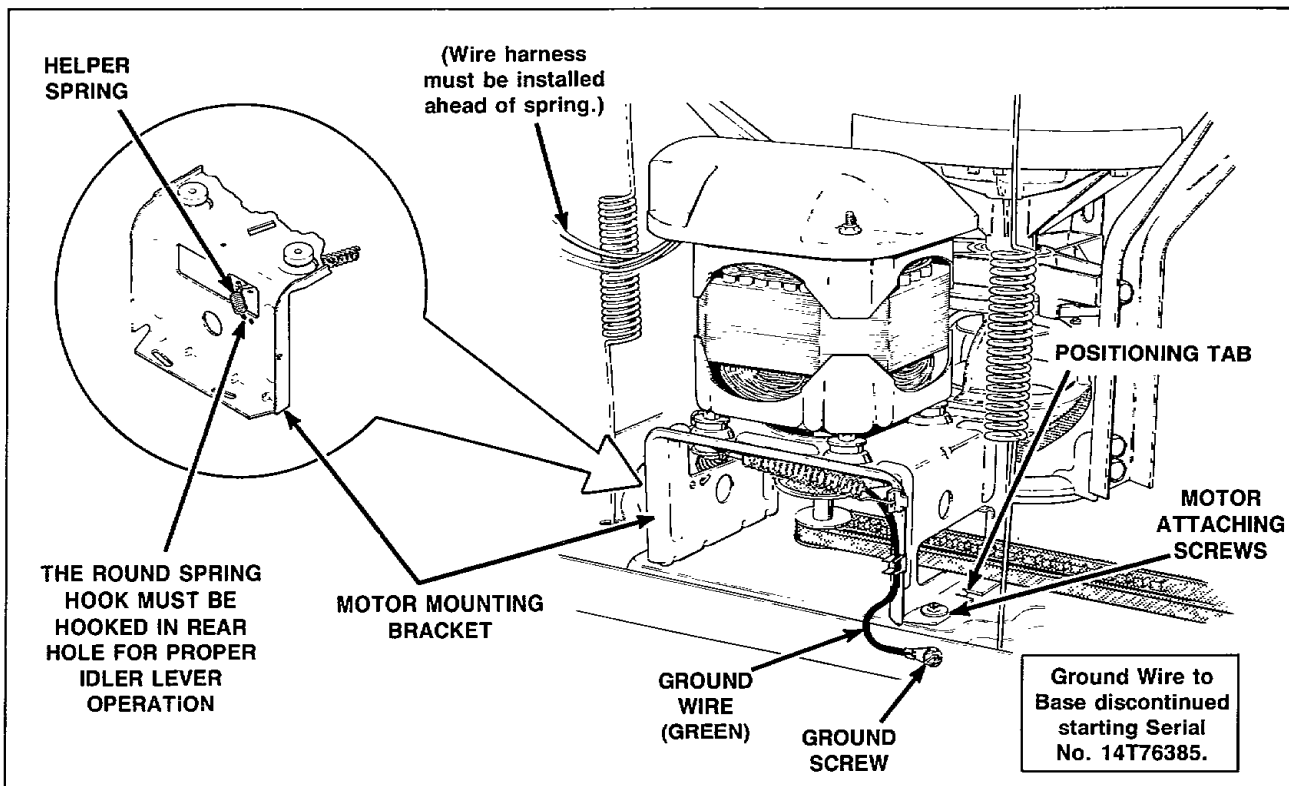

Figure 23

- d. Through Serial No. 14T76385: Remove screw holding ground wire to washer base, *Figure 23*.
- e. Remove four screws holding motor and mounting bracket to washer base, *Figure 23*, then lift complete assembly out of washer.

NOTE: When installing motor and mounting bracket, tab on right bottom flange of mounting bracket must be placed in positioning hole in base. Mounting bracket must be shifted toward rear of washer to its limit of travel within the mounting bracket attaching screws.

- f. Remove nuts, steel washers, spacers and rubber mounts holding motor to mounting bracket, *Figure 24*. Lift motor off mounting bracket and remove balance of rubber mounts and steel washers from motor mounting studs.

IMPORTANT: When installing motor on mounting bracket, position motor with switch facing toward left side of mounting bracket.

NOTE: Refer to *Figure 24* for motor and mounting bracket assembly sequence.

19. IDLER LEVER AND PULLEY

- a. Remove motor and mounting bracket, *paragraph 16*, steps "a" through "e".
- b. Remove nut, washer and bolt holding idler lever and pulley to motor mounting bracket.

NOTE: Refer to *Figure 24* for idler lever and pulley assembly sequence.

- c. Apply No. 21814 Lubricant to the area of the idler lever making contact with the motor mounting bracket.

20. MOTOR DRIVE PULLEY OR PUMP PULLEY

- a. Remove motor and mounting bracket, *paragraph 18*, steps "a" through "e".
- b. Lay motor and mounting bracket on its side.

NOTE: To remove pulleys, support motor shaft (to prevent bending shaft) and drive out pulley roll pins.

21. MOTOR SWITCH

- a. Remove front panel, *paragraph 15*.
- b. Remove nut holding motor shield to motor.
- c. Disconnect external wires from motor switch terminals.

NOTE: Refer to appropriate wiring diagram when rewiring switch.

- d. Remove two screws holding switch to motor.
- e. Disconnect internal motor leads from switch terminals.

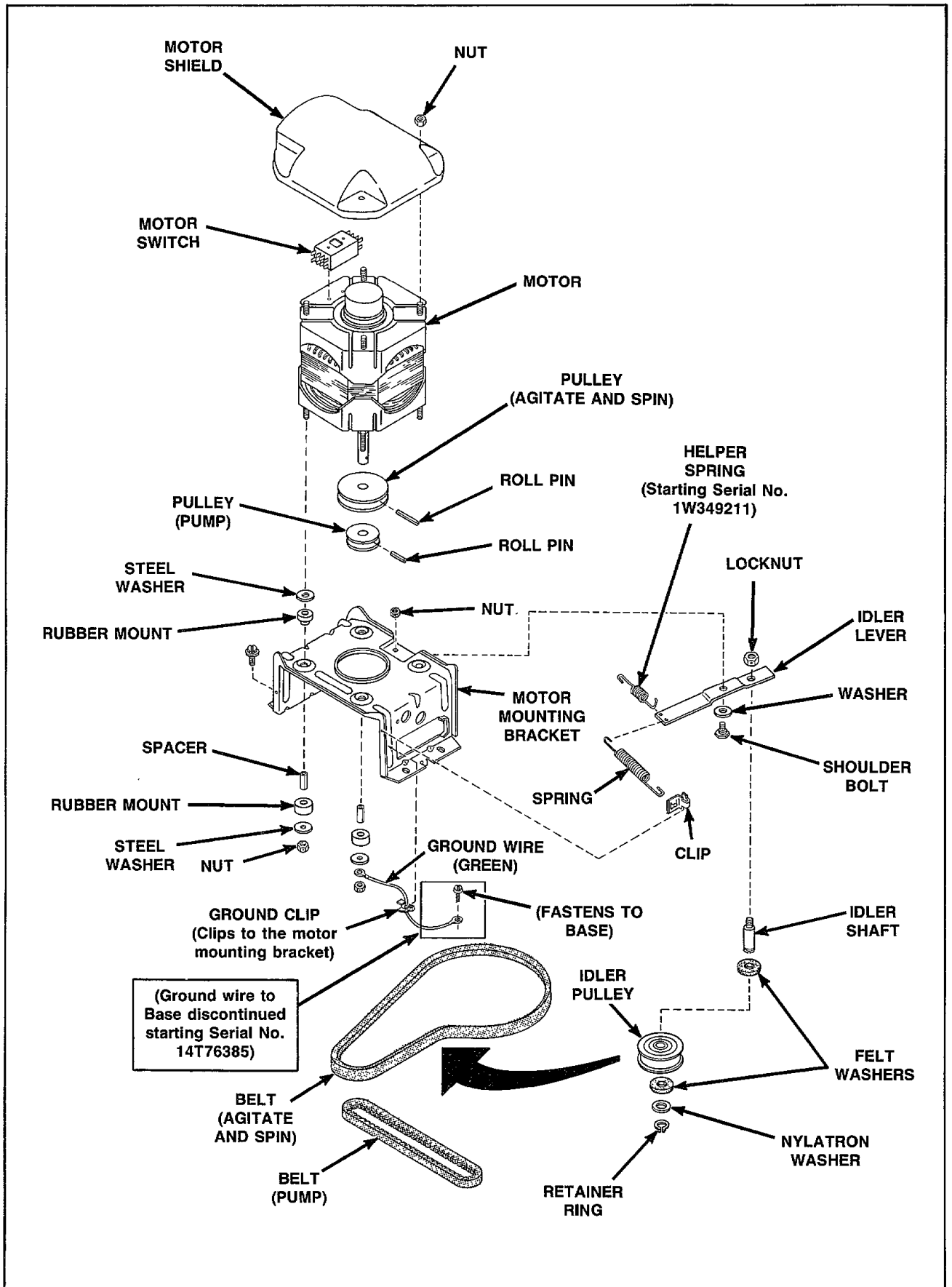

Figure 24

22. PUMP ASSEMBLY

- a. Remove front panel, *paragraph 15*.
- b. Remove pump belt, *paragraph 16*.

CAUTION

There will always be some water that will remain in the outer tub, therefore before removing hoses from the pump, the hoses will have to be pinched off or drained to prevent water spillage on the floor.

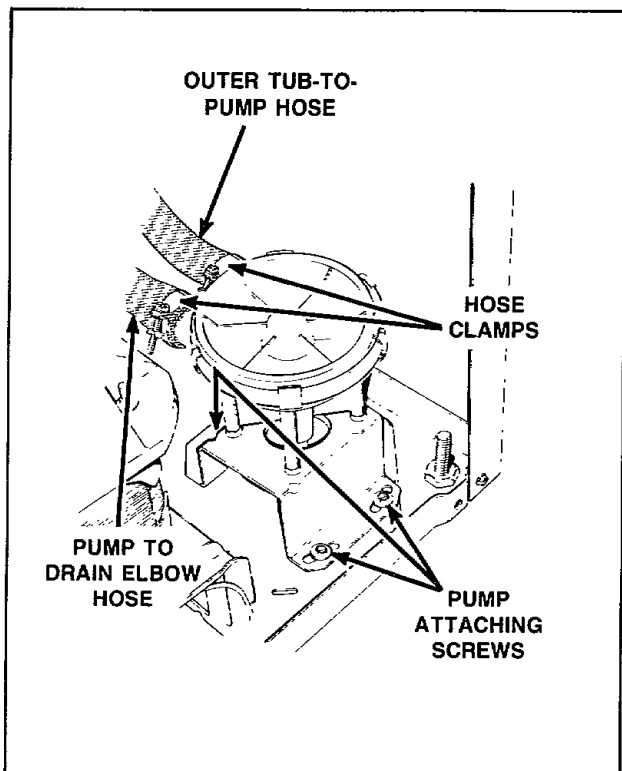

Figure 25

- c. Remove the two front mounting screws, *Figure 25*, and loosen the rear screw.

NOTE: Rear screw hole in pump mounting bracket is slotted, therefore, it is not necessary to remove the rear screw.

- d. Slide pump and mounting bracket toward rear of washer and lift assembly out of washer.
- e. Loosen hose clamps and remove all hoses from pump assembly, *Figure 25*.

Pump Mounting Bracket

Remove four hex head screws holding pump to mounting bracket.

NOTE: Refer to *Figure 26* for pump and mounting bracket assembly sequence.

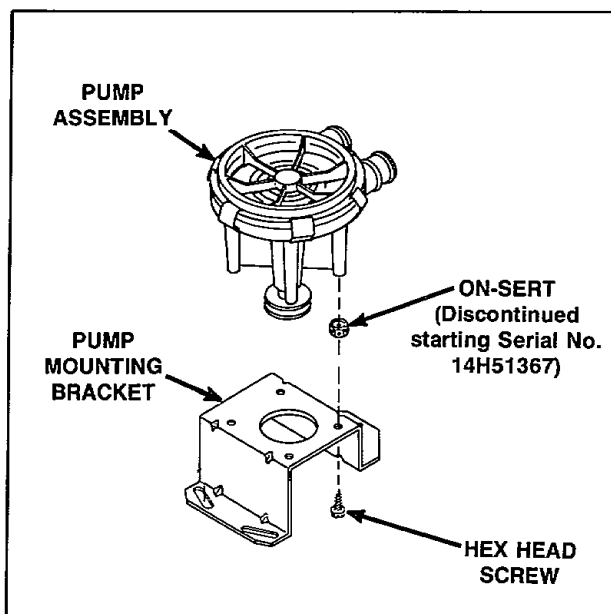

Figure 26

23. CABINET TOP ASSEMBLY

- a. Remove front panel, *paragraph 15*.
- b. Remove two cabinet top hold-down screws, *Figure 27*.
- c. Metered Models – Unlock and open meter case service door. Remove the inner cap screw holding timer and bracket to cabinet bracket.
- d. Slide timer and bracket to the left to disengage bracket from shoulder screw. Lift timer and bracket out of meter case through service door opening as far as wires will permit.
- e. Remove shoulder screw from inside of meter case.

NOTE: When installing shoulder screw, it must be installed in the outer hole, *Figure 3*, to enable the timer bracket to slide under the screw head.

- f. If the area or space permits, tape loading door closed and lift cabinet top to a vertical position by hinging it on the rear hold-down bracket.

NOTE: Cabinet top is self supporting, or use a small chain to support the cabinet top, *Figure 28*.

TO REMOVE CABINET TOP FROM WASHER

- a. Metered Models – Unlock and remove service door. Remove the inner cap screw holding timer and bracket to cabinet bracket.
- b. Slide timer and bracket to the left to disengage bracket from shoulder screw. Lift timer and bracket out of meter case through service door opening as far as wires will permit.

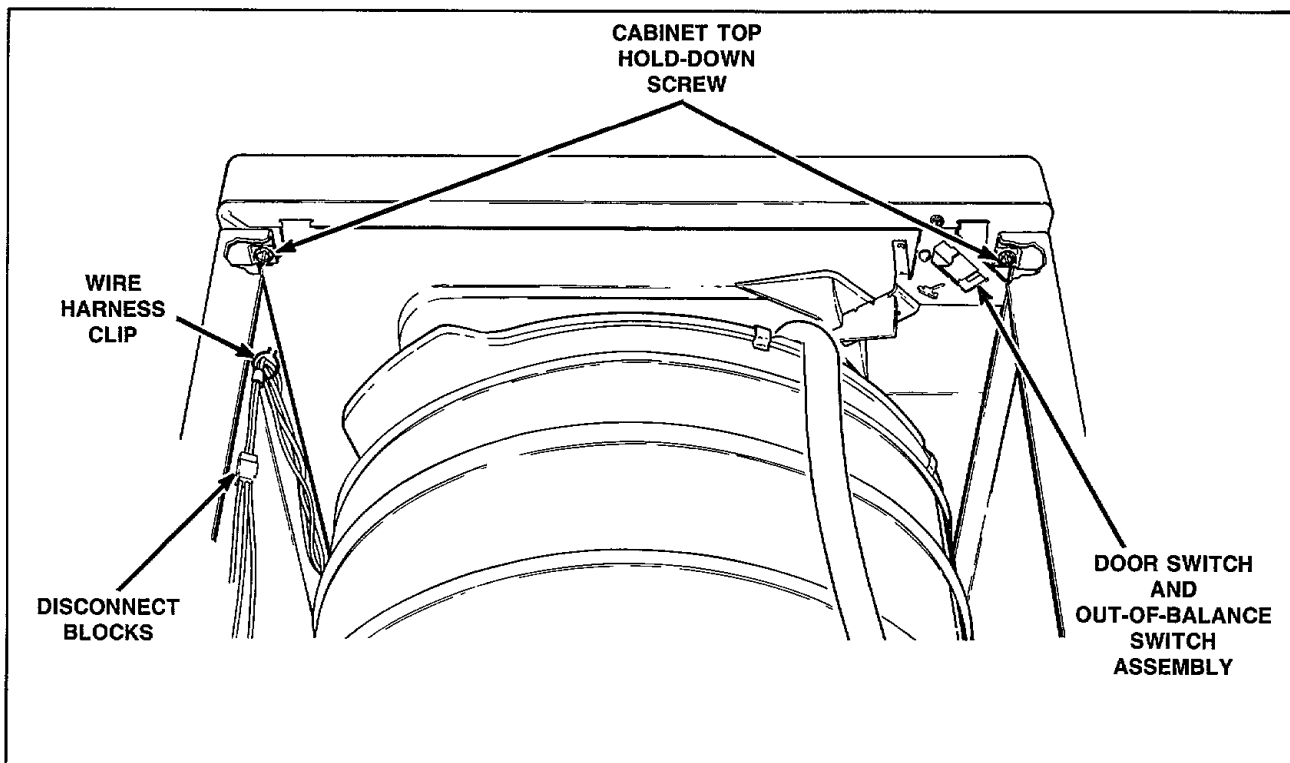

Figure 27

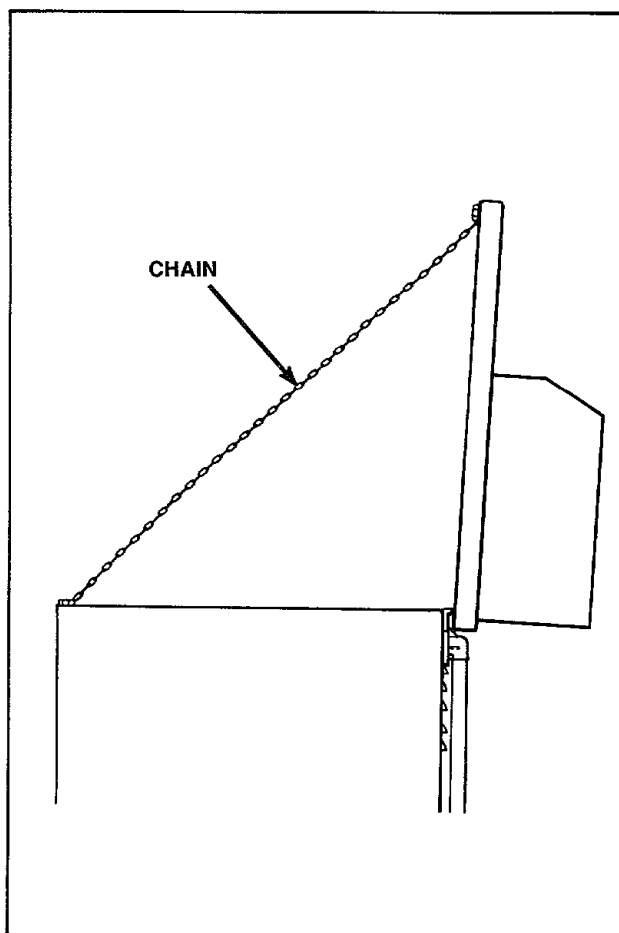

Figure 28

- c. Remove shoulder screw from inside of meter case.

NOTE: When reinstalling shoulder screw, it must be installed in the outer hole, *Figure 3*, to enable the timer bracket to slide under the screw head.

- d. Remove front panel, *paragraph 13*.
- e. Remove two cabinet top hold-down screws, *Figure 27*.
- f. Remove control panel, *paragraph 1*.
- g. Disconnect control hood harness from base wire harness at quick disconnect block.
- h. Disconnect pressure hose from pressure switch.

IMPORTANT: When installing pressure hose, blow air into hose before connecting hose to switch to remove any moisture that may have accumulated in the hose.

- i. Push base harness block and pressure hose down through hole in cabinet top.
- j. Tape loading door closed.
- k. Lift front of cabinet top slightly and pull forward to disengage from rear hold-down brackets and permit disconnecting green ground wire from rear top flange of washer cabinet.
- l. Carefully lift cabinet top off washer and set on protective padding.

NOTE: Do not damage door switch and out-of-balance switch assembly when removing cabinet top.

24. DOOR AND OUT-OF-BALANCE SWITCH AND BRACKET ASSEMBLY (Refer to Figure 29)

- a. Remove front panel, *paragraph 13*.
- b. Hinge cabinet top or remove, *paragraph 23*.
- c. Remove two screws holding switch and bracket assembly to underside of front flange of cabinet top.
- d. Disconnect wires from switch.

NOTE: Refer to wiring diagram when rewiring switch.

- e. Remove two screws holding switch to bracket.

NOTE: After installing switch and bracket assembly, adjust per *paragraph 41*.

25. MIXING VALVE ASSEMBLY

- a. Hinge cabinet top or remove, *paragraph 23*.
- b. Remove screw holding mixing valve to mounting bracket at rear of washer cabinet, *Figure 30*.

NOTE: When installing mixing valve, tab on bottom flange must be placed in positioning hole in mounting bracket.

- c. Pull mixing valve out toward front of washer far enough to permit disconnecting water inlet and fill hoses from mixing valve, *Figure 30*.
- d. Disconnect wires from mixing valve solenoid.

NOTE: Refer to appropriate wiring diagram when rewiring solenoids.

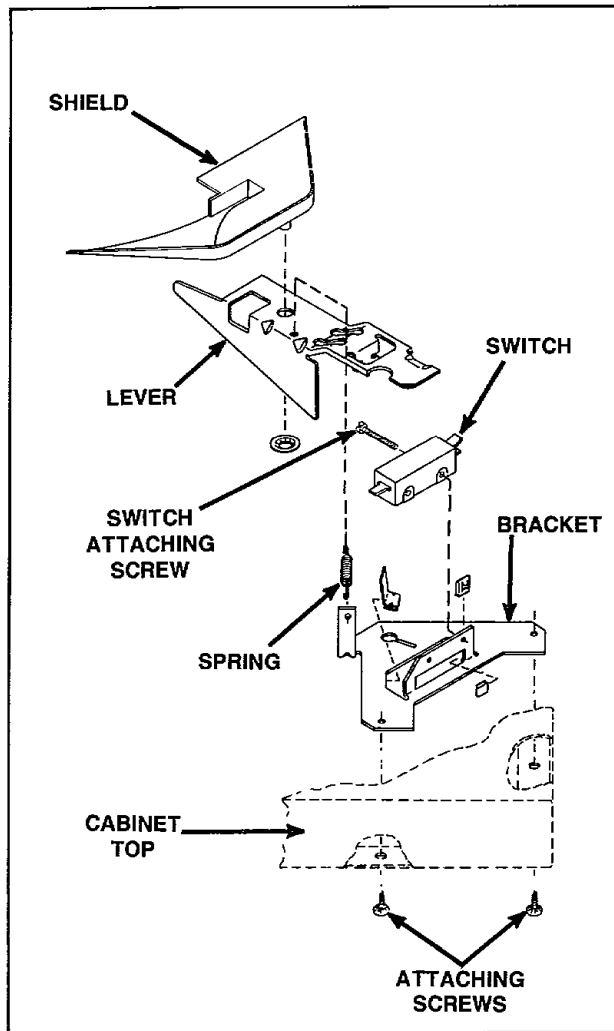

Figure 29

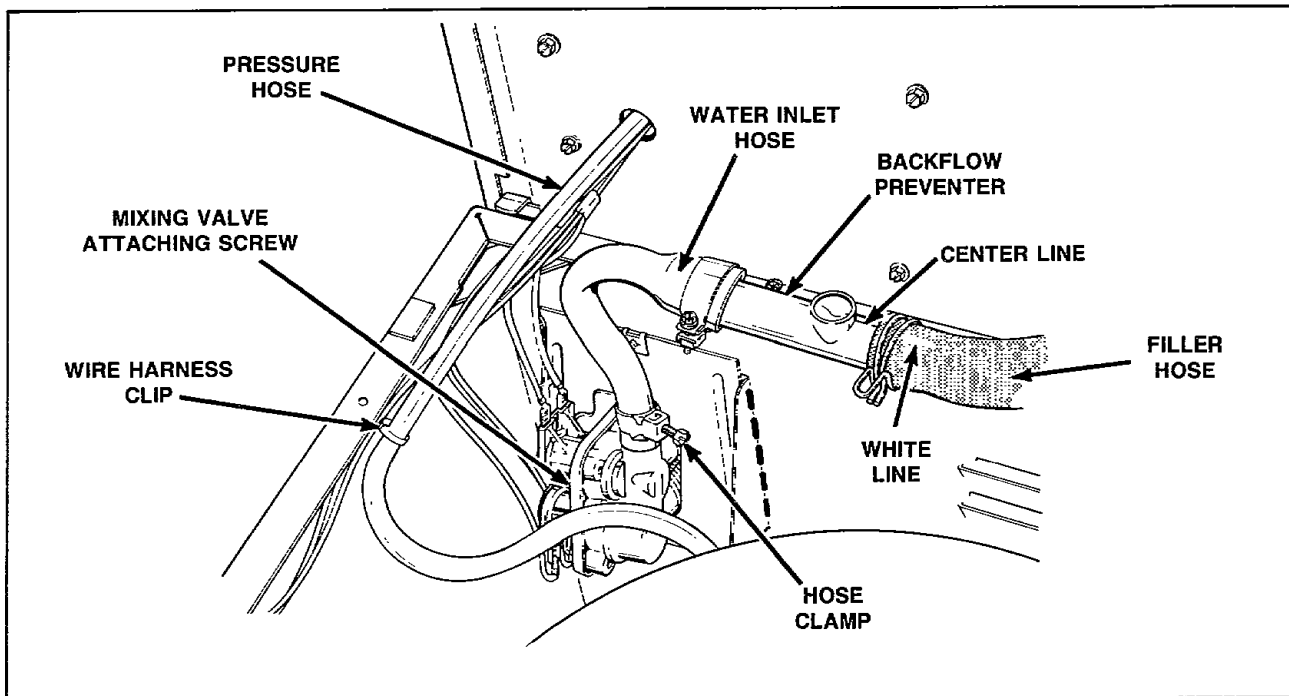

Figure 30

**26. WASHTUB AND LINT FILTER
SHORT POST MODELS**

- a. Remove agitator, *paragraph 11.*
- b. Hinge cabinet top or remove, *paragraph 23.*

Through Serial No. 14F02861

1. Disconnect water inlet hose from outer tub cover, *Figure 31.*

NOTE: When reinstalling filler hose, white line on hose must be aligned with center line of water inlet head, *Figure 31.*

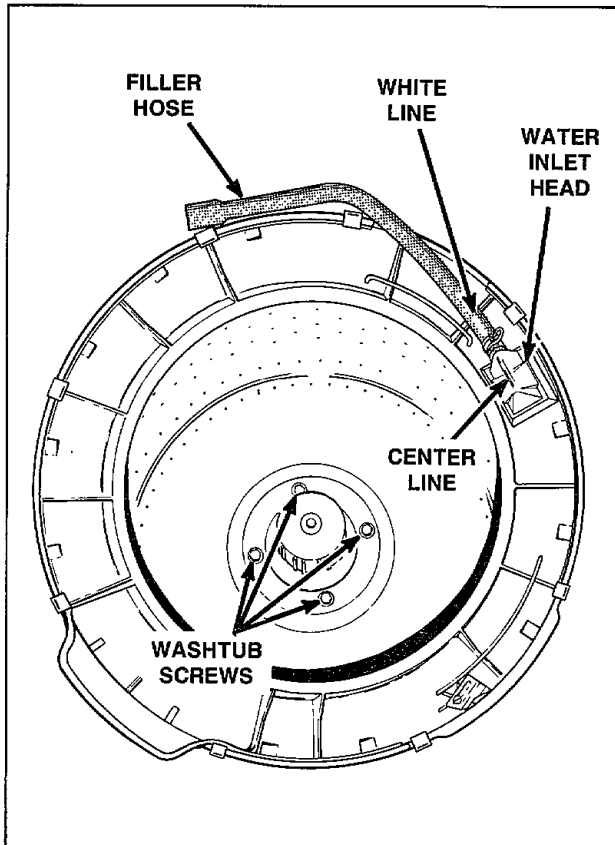

Figure 31

Starting Serial No. 14F02862

1. Disconnect filler hose from backflow preventer, *Figure 30.*

NOTE: When installing filler hose, white line on hose must be aligned with center line of backflow preventer, *Figure 30.* A 1/8 inch clearance is necessary to prevent the hose from rubbing on the flange of the tub cover, *Figure 32.* Loosen hose clamp and move hose to obtain the proper clearance.

2. Remove eight clips holding outer tub cover to tub, *Figure 32,* lift cover off tub and set beside washer cabinet.

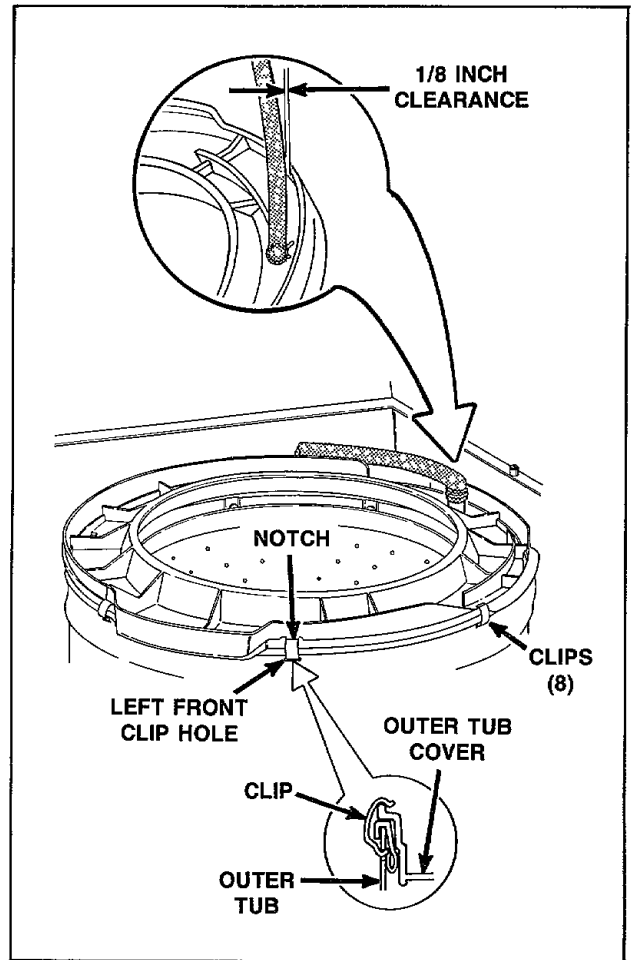

Figure 32

NOTE: When installing outer tub cover, always use a new cover gasket. Lubricate the gasket with liquid soap to aid in assembly. Cover must be placed on outer tub so notch on top edge of outer tub cover is directly over left front clip hole in tub, *Figure 32.* Starting with this hole, place each spring clip in its respective hole and snap in place. See *Figure 32* for proper clip installation.

3. Remove four screws and washers holding washtub to hub, *Figure 31.*

IMPORTANT: Porcelain Washtub Models – Use caution when tightening the screws to avoid chipping porcelain on the washtub.

4. Lift washtub and lint filter out of outer tub.

CAUTION

When removing the washtub and lint filter, DO NOT lift up on the lint filter as you could damage the filter. Grasp the top flange of the washtub and remove from outer tub.

NOTE: When installing washtub, always use a new gasket between the tub and hub.

TO REMOVE LINT FILTER FROM WASHTUB

- Place a small screwdriver in behind the slots provided in the lint filter, *Figure 33*.
- Carefully pry the pins of the lint filter out of the holes in the washtub, *Figure 33*.

NOTE: As you are prying out the pins, lift up on the filter.

- Pry the filter pins out of the washtub holes approximately half way around the tub before the filter can be removed.

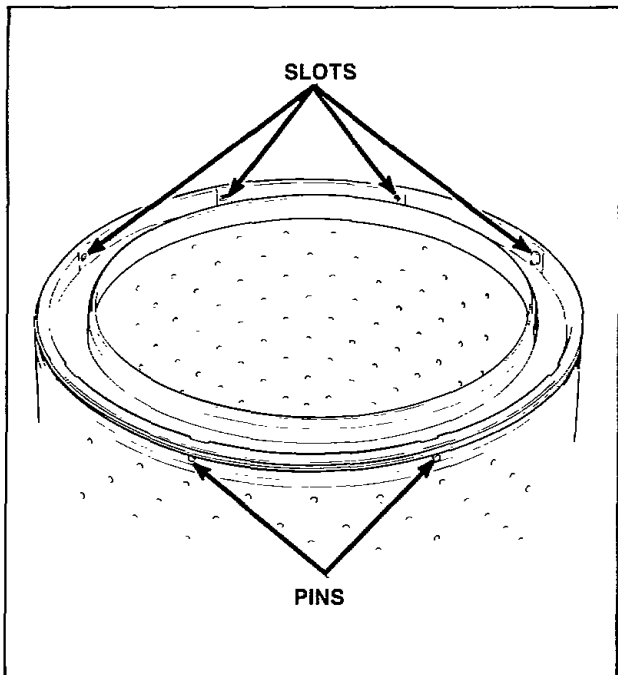

Figure 33

TO INSTALL LINT FILTER IN WASHTUB

Place the lint filter on top of washtub, making sure the filter pins line up with the holes in the washtub. Then carefully push the filter down into the washtub until all the pins snap into their respective holes.

LONG POST MODELS

- Remove agitator hold-down cap and lift agitator out of washtub, *Figure 18*.
- Hinge cabinet top or remove, *paragraph 23*.
- Disconnect water inlet hose from outer tub cover, *Figure 34*.

NOTE: When installing filler hose, white line on hose must be aligned with center line of water inlet head, *Figure 34*.

- Remove eight clips holding outer tub cover to tub, *Figure 35*.

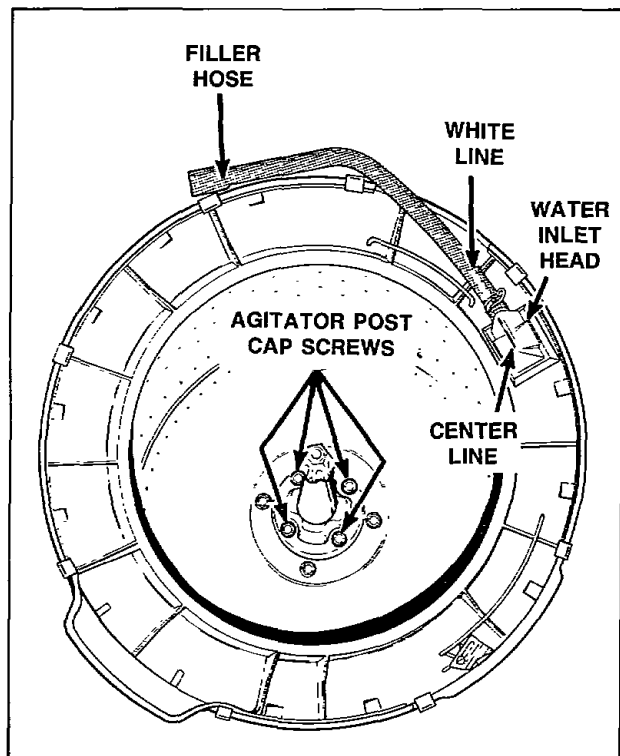

Figure 34

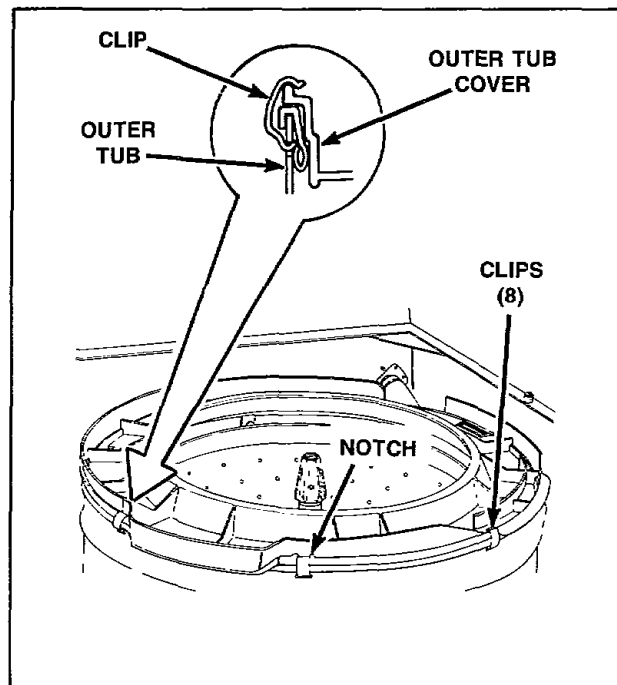

Figure 35

NOTE: When installing outer tub cover, always use a new cover gasket. Lubricate the gasket with a rubber lube or liquid soap to aid in assembly. Cover must be placed on outer tub so notch on top edge of outer tub cover is directly over left front clip hole in tub, *Figure 35*. Starting with this hole, place each spring clip in its respective hole and snap in place. See *Figure 35* for proper clip installation.

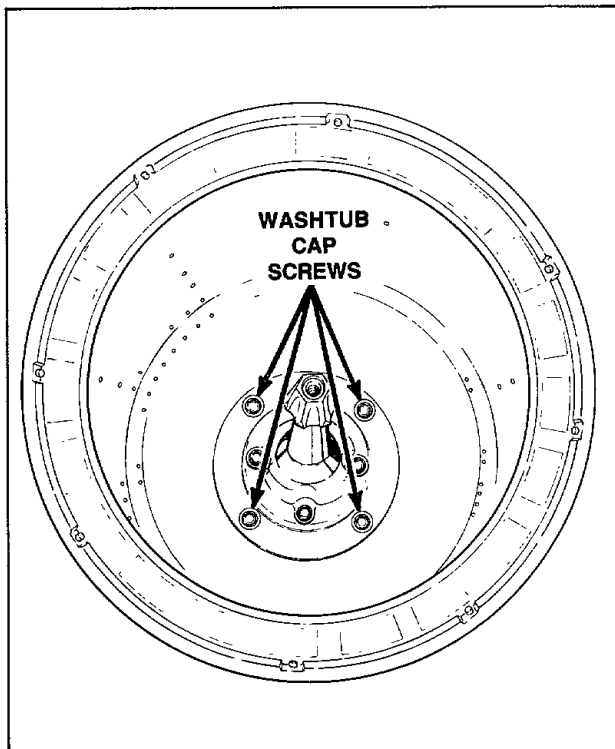

Figure 36

- e. Remove four cap screws and washers holding washtub to hub, *Figure 36*.

IMPORTANT: Use caution when installing cap screws to avoid chipping porcelain on the washtub.

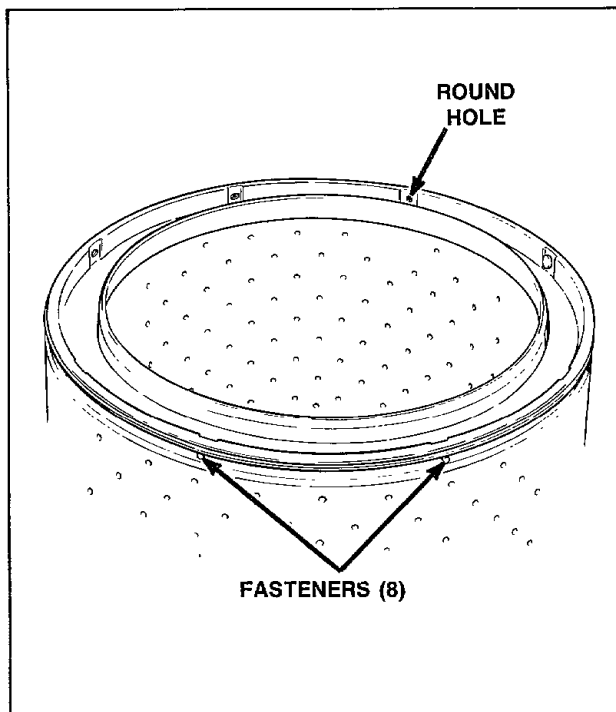

Figure 37

- f. Lift washtub and lint filter out of outer tub.

NOTE: When installing washtub, use a new gasket between tub and hub.

- g. Remove the eight fasteners holding lint filter to washtub, *Figure 37*.

27. WATER SEAL AND HUB ASSEMBLY (Short Post Models)

⚠ WARNING

If water is present in washtub, spin and pump out before removing the drive belt.

- Remove two screws from bottom edge of front panel, *Figure 20*.
- Pull bottom of panel away from washer until hold-down clips (located on top flange of panel) disengage from slots in cabinet top, *Figure 20*.
- Remove two cabinet top hold-down screws, *Figure 20*.
- Remove agitator, *paragraph 11*.
- Disconnect filler hose from backflow preventer, then remove the eight clips holding cover to outer tub, *Figure 35*.

NOTE: When reinstalling filler hose, white line on hose must be aligned with center line of backflow preventer, *Figure 30*.

- Lift cover off outer tub and set beside washer cabinet and remove old cover gasket.
- Remove the four screws holding washtub to hub, *Figure 31*, then lift washtub out of outer tub.

⚠ CAUTION

When removing the washtub, **DO NOT** lift up on the lint filter as you could damage the filter. Grasp the top flange of the washtub and remove from outer tub.

NOTE: Be sure all traces of old gasket are removed from bottom of washtub.

- Remove agitator drive bell, *paragraph 12*.
- Remove the seal head from the hub.

IMPORTANT: We recommend that both the seal seat and the seal head be replaced together in pairs. **DO NOT** replace only one of the two seals.

(continued)

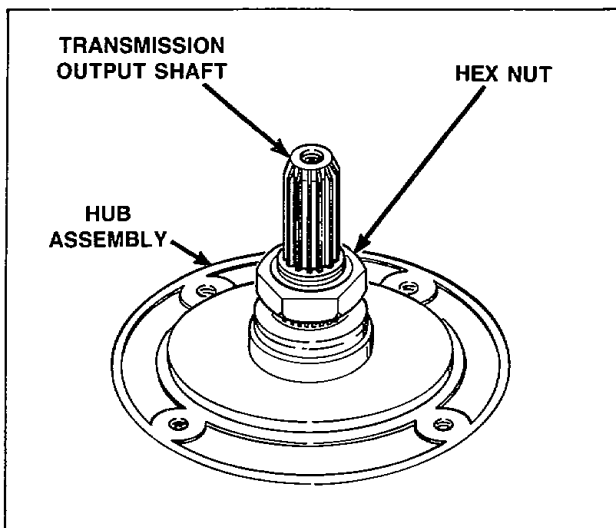

Figure 38

- j. Remove the large hex nut, *Figure 38*, using No. 237P4 Hex Wrench.
- k. Remove the spline insert from the transmission tube.

⚠ WARNING

Use a new spline insert each time the hex nut is removed. **DO NOT** reuse the old insert as the hex nut may loosen during operation.

- l. Remove hub from splines on transmission tube.

NOTE: It may be necessary to use a gear puller to remove the hub.

- m. Remove the old water seal from the outer tub.

IMPORTANT: Use caution when removing the old seal so as not to damage the tub flange or porcelain.

TO INSTALL NO. 441P3 HUB AND SEAL KIT

IMPORTANT: Be sure the inner surface of the tub flange is clean of all foreign material before installing the new seal.

- a. Apply a small amount of No. 27615P Sealant (supplied in kit) around the outer surface of the tub flange, *Figure 39*.

⚠ CAUTION

DO NOT allow sealant to get in contact with the flinger, *Figure 39*, as this could prevent the flinger from keeping moisture out of the upper bearing.

- b. Apply a light film of non-staining petroleum jelly (such as Vaseline®) to the bronze portion of water seal and to the outer surface of the stainless steel sleeve, *Figure 40*.

⚠ WARNING

Do not over lubricate!

- c. Insert the stainless steel sleeve into the water seal from the bottom side of the seal, *Figure 40*, until the sleeve is flush with the bronze portion of the seal.
- d. Leave the garter spring on the seal. Place the new seal over the outer tub flange (with seal lip on outside of tub flange). Then press the seal into the tub flange opening using moderate finger pressure.
- e. Carefully apply a small amount of No. 27615P Sealant (supplied with kit) around the outer edge of seal and tub. (The area located just below the garter spring, *Figure 40*.)

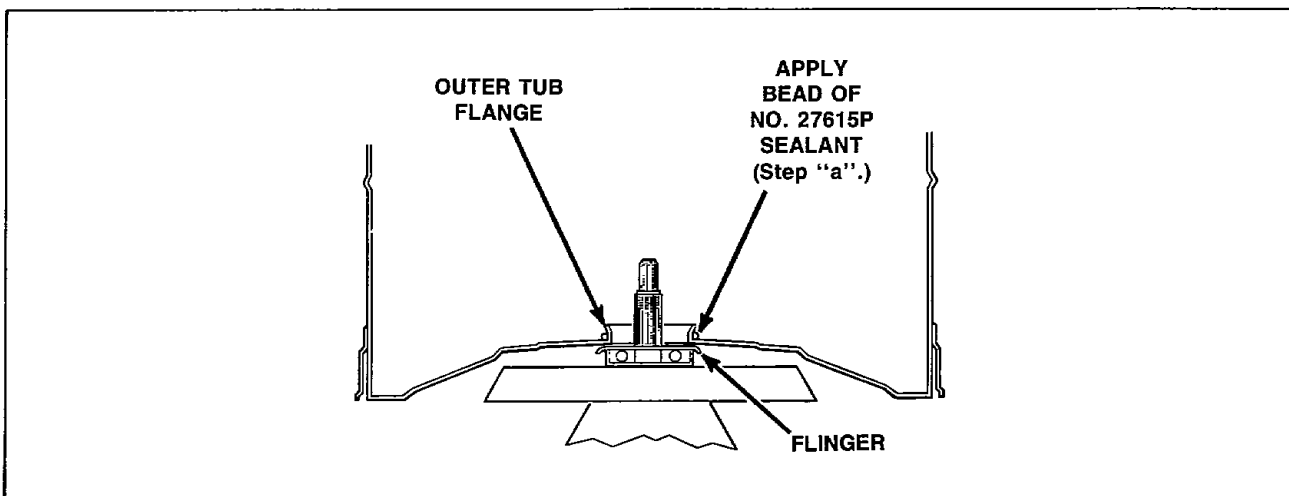

Figure 39

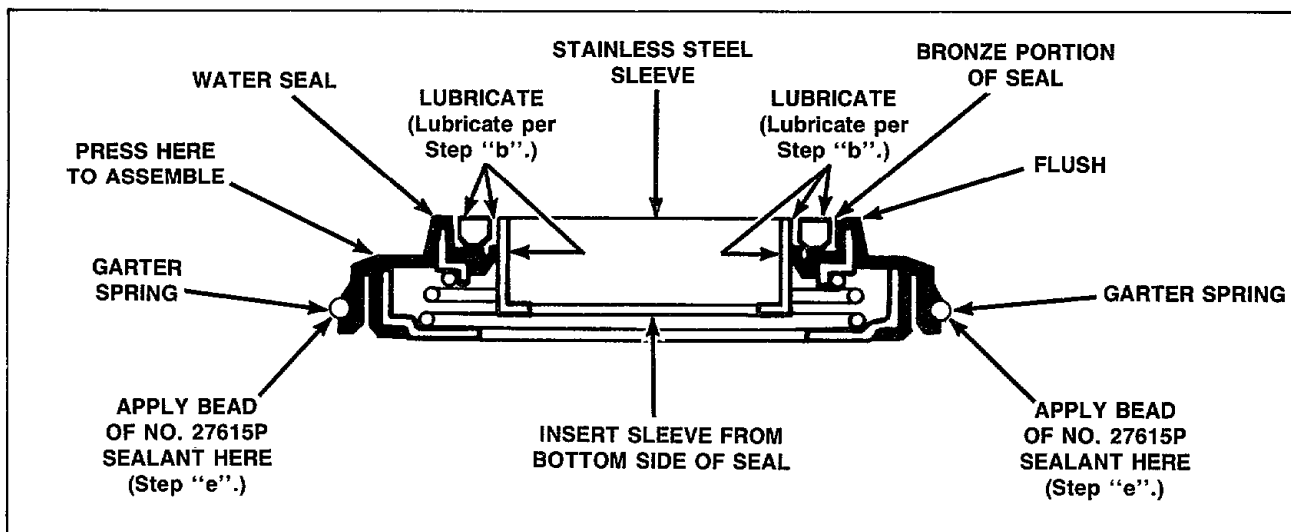

Figure 40

WARNING

Do not allow sealant to get in contact with the sealing surface of the water seal as it will cause a water leak.

- f. Lubricate the inner splines of the new hub assembly (supplied in kit) with No. 27604P Anti-Sieze Compound.
- g. Carefully place the new hub assembly on splined transmission tube.

IMPORTANT: Firmly push hub down against the outer tub seal and hold in this position.

- h. While holding the hub down, place the spline insert onto the transmission tube until it bottoms against the hub. Then place the hex nut on the transmission tube (with the larger inside bevel on the nut toward the spline insert), then tighten the nut.

IMPORTANT: Torque hex nut down between 40 to 70 foot pounds (54.23 to 94.91 N-m). If torque wrench is not available, tap hex wrench with a hammer until hub turns or until nut will no longer tighten.

- i. Apply a small amount of non-staining petroleum jelly (such as Vaseline®) to each of the sealing surfaces where washtub gasket will contact hub and the bottom of washtub.
- j. Carefully place the new washtub gasket (supplied in kit) on hub.

NOTE: Be sure holes in gasket are aligned with bolt holes in hub and that all traces of the old gasket are removed from the bottom of the washtub.

- k. Install washtub by grasping the top flange of the washtub and carefully lower washtub down onto the gasket and hub.

IMPORTANT: Before setting tub into place, be sure bolt holes in washtub line up with holes in gasket and hub.

- l. Secure washtub to hub using four screws previously removed.

IMPORTANT: Porcelain Washtub Models – Use caution when tightening cap screws to avoid chipping porcelain on the washtub.

- m. Carefully place the new outer tub cover gasket (supplied in kit) around top rim of outer tub.

NOTE: When installing outer tub cover, lubricate the cover gasket with liquid soap to aid assembly. Cover must be placed on outer tub so notch on top edge of outer tub cover is directly over left front clip hole in tub, Figure 32. Starting with this hole, place each spring clip in its respective hole and snap into place, refer to Figure 32 for proper clip installation.

- n. Reinstall filler hose on backflow preventer.

NOTE: When reinstalling the filler hose, white line on hose must be aligned with the center line of the backflow preventer, Figure 30.

TO INSTALL DRIVE BELL AND NO. 442P3 SEAL KIT

- a. Place the new seal head (supplied in kit) onto hub. Then carefully push seal head into position using the large end of No. 255P4 Seal Tool. Make sure the seal is pressed down against the shoulder on the hub.

NOTE: Soapy water will aid in the assembly of the seal onto the hub.

(continued)

- b. Install the new seal (supplied in kit) into the drive bell using the small end of the No. 255P4 Seal Tool.
- c. Position drive bell until splines in drive bell line up with splines on transmission shaft.
- d. Place the No. 253P4 Bell Tool over top of bell. Screw bolt into transmission shaft until it bottoms out.

NOTE: It is not necessary to clamp the tool jaws on the drive bell during this operation.

- e. Use an adjustable wrench and turn the large nut on the tool **CLOCKWISE** to force the drive bell down onto transmission shaft until the bell bottoms out on the shaft.
- f. Turn the bolt out of the transmission shaft and remove the tool.
- g. Install the new screw and "O" ring washer (supplied in kit) in top of drive bell.

NOTE: Torque the new screw down between 45 to 55 inch pounds. Over torque will mushroom the plastic bell.

- h. Place the agitator on top of the drive bell. Slowly rotate the agitator until the fingers on the underside of agitator line up with the large slots in drive bell.
- i. A sharp blow on top of the agitator, with the palm of your hand, will force the agitator down onto the drive bell, allowing the fingers on the underside of the agitator to lock under the bottom edge of the drive bell.

NOTE: Do not push the agitator onto the drive bell any further than necessary.

- j. Reinstall cabinet top and secure to washer cabinet using screws previously removed.
- k. Reinstall front panel.
- l. Place washer into the final spin, close loading door, start washer and let washtub spin for approximately 30 seconds to one minute.

IMPORTANT: Step "l" is necessary to allow the petroleum jelly, applied to the water seal, a chance to run in on the seal surfaces before water is added to the washer.

28. WATER SEAL ASSEMBLY (Long Post Models)

⚠ WARNING

If water is present in washtub, spin and pump out before removing agitator post.

NOTE: When installing lint filter, it is necessary to start the first fastener in the round hole, Figure 38. Place the remaining fasteners in their respective holes.

- a. Remove front panel, *paragraph 15.*
- b. Remove two cabinet top hold-down screws and hinge cabinet top or remove from washer, *paragraph 23.*
- c. Remove agitator hold-down cap and lift agitator out of washtub.
- d. Disconnect filler hose from backflow preventer, then remove the eight clips holding cover to outer tub, *Figure 35.*

NOTE: When reinstalling filler hose, white line on hose must be aligned with center line of backflow preventer, Figure 30.

- e. Lift cover off outer tub and set beside washer cabinet and remove old gasket.
- f. Remove the four cap screws holding washtub to hub, *Figure 36*, then lift washtub out of outer tub.

NOTE: Be sure all traces of old gasket are removed from bottom of washtub.

- g. Remove four cap screws holding agitator post assembly to hub, then lift assembly from hub.
- h. Straighten bent tab(s) on lockwasher, *Figure 41*, then remove hex nut using No. 237P4 Hex Wrench.
- i. Remove hub from splines on transmission tube.

NOTE: It may be necessary to use a gear puller with No. 230P4 Guide Tool to remove hub.

- j. Remove old seal from outer tub.

IMPORTANT: Use caution when removing old seal so as not to damage the tub flange or porcelain.

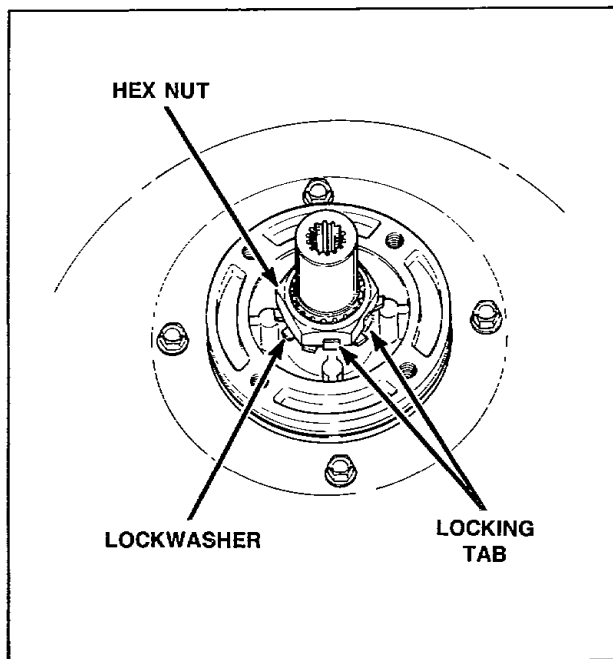

Figure 41

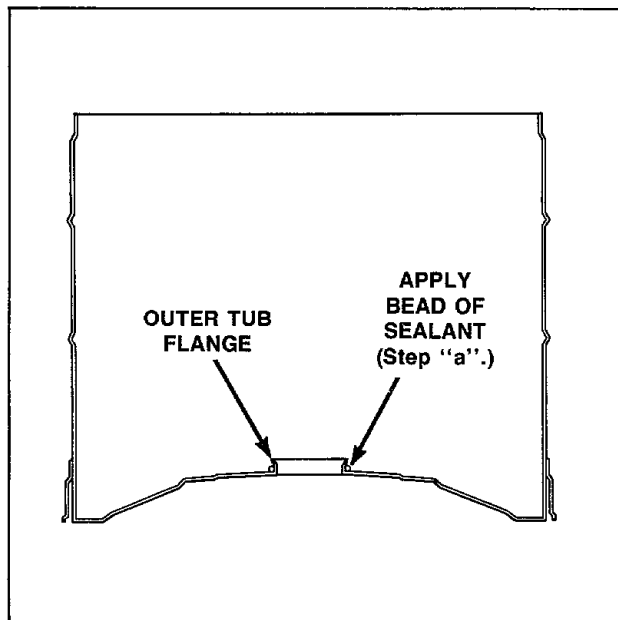

Figure 42

TO INSTALL NO. 356P3 WASHER SEAL KIT

IMPORTANT: Be sure the inner surface of the tub flange is clean of all foreign material before installing the new seal.

- a. Apply a small amount of No. 27615 Sealant (supplied in kit) around the outer surface of the tub flange, *Figure 42*.

⚠ CAUTION

DO NOT allow sealant to get in contact with the flinger located below the flanged area.

- b. Apply a small amount of non-staining petroleum jelly (such as Vaseline®) to the bronze portion of water seal and to the outer surface of the stainless steel sleeve.

⚠ WARNING

Do not over lubricate!

- c. Insert the stainless steel sleeve into the water seal from the bottom side of the seal, *Figure 43*, until the sleeve is flush with the bronze portion of the seal.
- d. Leave the garter spring on the seal. Place the new seal over the outer tub flange (with seal lip on outside of tub flange). Then press the seal into the tub flange opening using moderate finger pressure.
- e. Carefully apply a small amount of No. 27615 Sealant (supplied in kit) around the outer edge of seal and tub (the area located just below the garter spring, *Figure 43*).

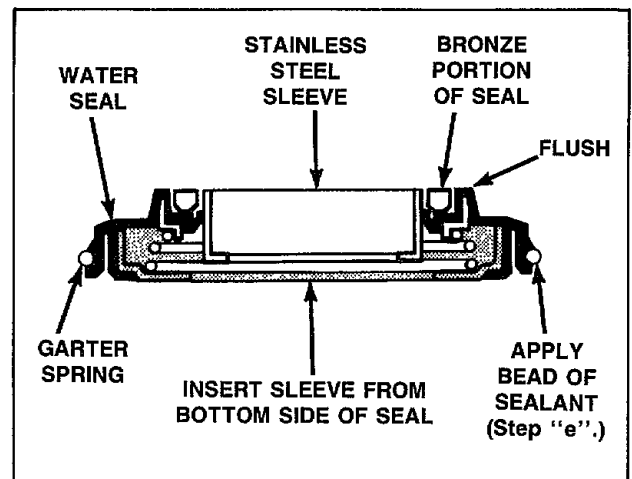

Figure 43

⚠ WARNING

Do not allow sealant to contact the sealing surfaces of the water seal!

- f. Lubricate the inner splines of the new hub assembly (supplied in kit) with No. 27604P Anti-Sieze Compound.
- g. Carefully place the new hub assembly on splined transmission tube and install lockwasher and hex nut, *Figure 41*.

NOTE: Locknut must be installed with beveled side down.

IMPORTANT: Torque hex nut down between 40 to 70 foot pounds (54.23 to 94.91 N-m). If torque wrench is not available, tap hex wrench with a hammer until hub turns or until nut will no longer tighten. After nut has been tightened, bend at least two locking tabs on lockwasher into place on hex nut, *Figure 41*.

- h. Apply a small amount of non-staining petroleum jelly (such as Vaseline®) to each of the sealing surfaces where washtub gasket will contact hub.
- i. Carefully place the new washtub gasket (supplied in kit) on hub.

NOTE: Be sure holes in gasket are aligned with bolt holes in hub.

- j. Apply a small amount of non-staining petroleum jelly (such as Vaseline®) to top surface of gasket where bottom of washtub will contact gasket.

NOTE: Be sure all traces of old gasket are removed from bottom of washtub.

- k. Install washtub by grasping underside of lint filter and carefully lower washtub down onto gasket and hub.

(continued)

IMPORTANT: Before setting tub into place, be sure bolt holes in washtub line up with holes in gasket and hub.

- i. Secure washtub to hub using four cap screws previously removed.

IMPORTANT: Use caution when tightening cap screws to avoid chipping porcelain on the washtub.

NOTE: If Loctite was originally used between the agitator post and hub, the Loctite must be used again when replacing the agitator post. Be sure all traces of the Loctite has been removed from the underside of the agitator post. Apply approximately a 1/16 inch diameter continuous bead of No. 28434P Loctite to the embossed surfaces of either the agitator post or hub. Then continue on with step "m".

If gasket was originally used between agitator post and hub, then use the new gasket (supplied in kit) and install gasket and agitator post as follows:

1. Apply a small bead of Sealant No. 27615 to each of the sealing surfaces where the agitator post gasket will contact the hub.
2. Carefully place the new agitator post gasket, No. 27020 (supplied in kit), on hub.

NOTE: Be sure holes in gasket are aligned with bolt holes in hub.

3. Apply two small beads of Sealant No. 27615 to the top surface of gasket where bottom of agitator post casting will contact gasket.

NOTE: Be sure all traces of the old gasket are removed from the bottom of agitator post.

- m. Carefully lower agitator post assembly down onto hub.

IMPORTANT: Before setting post in place, make sure splines on bottom end of agitator drive shaft line up with splines into coupling on transmission, and holes in agitator post line up with the bolt holes in hub.

NOTE: It may require tapping lightly on drive block to force splines on drive shaft into the coupling on transmission assembly.

- n. Secure agitator post to hub using cap screws previously removed.
- o. Carefully place new outer tub cover gasket (supplied in kit) around top rim of outer tub.

NOTE: When installing outer tub cover, lubricate the cover gasket with liquid soap to aid assembly. Cover must be placed on outer tub so notch on top edge of outer tub cover is directly over left front clip hole in tub, *Figure 35*. Starting with this hole, place each spring clip in its respective hole and snap into place, refer to *Figure 35* for proper clip installation.

- p. Reinstall filler hose on backflow preventer.

NOTE: When installing filler hose, white line on hose must be aligned with center line of backflow preventer, *Figure 30*.

- q. Reinstall cabinet top and secure to washer cabinet using screws previously removed.
- r. Reinstall front panel.
- s. Replace agitator and tighten agitator hold-down cap.
- t. Turn washer timer to the final spin, close loading door, start washer and let washtub spin for approximately 30 seconds to one minute.

IMPORTANT: Step "t" is necessary to allow the petroleum jelly, applied in step "b", a chance to run in on the seal surfaces before water is added to the washer.

29. OUTER TUB (Short Post Models)

WARNING

If water is present in washtub, spin and pump out before removing drive bell.

- a. Remove agitator, *paragraph 11*.
- b. Remove front panel, *paragraph 15*.
- c. Remove two cabinet top hold-down screws and hinge cabinet top or remove, *paragraph 23*.
- d. Loosen hose clamp and disconnect filler hose from backflow preventer, then remove the eight clips holding cover to the outer tub, *Figure 32*.

NOTE: When reinstalling filler hose, white line on hose must be aligned with center line of backflow preventer, *Figure 30*.

- e. Remove cover from outer tub and set off to the side to avoid damage, then remove old gasket.

NOTE: When installing outer tub cover, always use a new cover gasket. Lubricate the gasket with liquid soap to aid in assembly. Cover must be placed on outer tub so notch on top edge of outer tub cover is directly over left front clip hole in tub, *Figure 32*. Starting with this hole, place each spring clip in its respective hole and snap in place. See *Figure 32* for proper clip installation.

- f. Remove four screws and washers holding washtub to hub, *Figure 31*.

IMPORTANT: Porcelain Washtub Models – Use caution when tightening cap screws to avoid chipping porcelain on the washtub.

- g. Lift washtub (with lint filter attached) out of outer tub.

▲ CAUTION

When removing the washtub and lint filter, **DO NOT** lift up on the lint filter as you could damage the filter, Grasp the top flange of the washtub and remove from outer tub.

- h. Remove agitator drive bell, *paragraph 12*.
- i. Remove the large hex nut using No. 237P4 Hex Wrench. Then remove the spline insert from transmission tube.

▲ WARNING

Use a new spline insert each time the hex nut is removed, **DO NOT** reuse the old insert as the hex nut may loosen during operation.

- j. Remove hub from splines on transmission tube.

NOTE: It may be necessary to use a gear puller to remove the hub.

- k. Remove the old water seal from the outer tub.

IMPORTANT: Use caution when removing the old seal so as not to damage the tub flange or porcelain.

NOTE: When reinstalling or replacing outer tub, always install a new No. 441P3 Water Seal and Hub Kit, *paragraph 27*.

- l. Reach in through front of motor mounting bracket and move idler lever to the left to release tension on belt.

IMPORTANT: Use caution when releasing the idler lever tension. If the idler lever spring, or helper spring, are overstretched, it will affect the washer operation.

- m. While holding idler lever, reach in and around right side of motor and run belt off right side of pulley.

IMPORTANT: When removing or reinstalling the complete outer tub into the washer (with transmission, balance ring and pivot dome attached), damage could occur to the idler lever if the idler spring and helper spring are left hooked to the motor mounting bracket.

With the idler spring and helper spring hooked to the motor mounting bracket, the idler lever extends out through the rear of the bracket. When removing or reinstalling the complete tub assembly, the idler lever is in the way and can be damaged (bent), or the idler pulley could be chipped. A bent idler lever will cause misalignment of the idler pulley with the drive belt, and a chipped idler pulley will damage the belt.

We recommend that before removing or reinstalling the complete assembly, you unhook the idler spring and helper spring and move the idler lever out of the way. This will prevent the possibility of idler lever or pulley damage.

- n. Using the No. 229P4 Spring Hook Tool, unhook the five centering springs from lower edge of outer tub, *Figure 44*.

(continued)

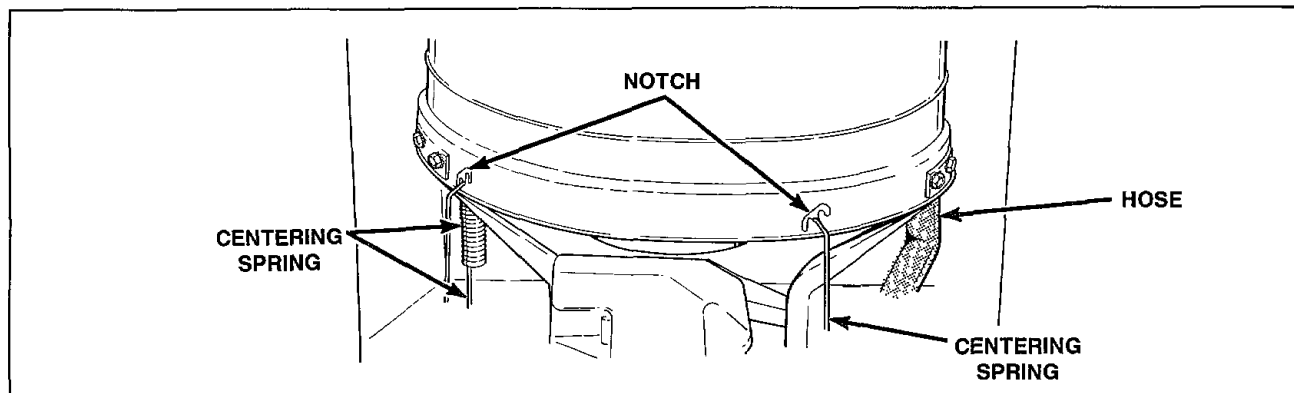

Figure 44

IMPORTANT: When removing centering springs, mark on side of outer tub what notch the spring was hooked into. Springs must be placed in the same notch when reinstalling. Do not overstretch springs.

- o. Disconnect hoses between outer tub and pump assembly.
- p. Remove hose clamp holding pressure hose to pressure accumulator. Then remove tape holding pressure hose to outer tub.
- q. Grasp outer tub and lift complete tub assembly (with transmission, balance ring and pivot dome attached) straight up and out of washer cabinet.
- r. Turn the outer tub upside-down and set on protective padding.
- s. Remove screws and lockwashers holding each support leg to outer tub, *Figure 45*. Then lift transmission, balance ring and pivot dome off tub.

NOTE: To prevent porcelain damage, leg plates must be installed on both sides of the outer tub flange when reinstalling support legs. (The thinner plate must be installed between leg and tub flange and the thicker plate must be installed on the outside of tub flange.) Do not overtighten the screws as this could cause stripping or porcelain damage.

- t. Turn outer tub upright and remove the pressure accumulator and grommet.

NOTE: When installing the grommet into the outer tub, the thicker lip of the grommet must be installed to the outside of the tub. Lubricate the outer surface of the large opening of the accumulator with liquid soap to aid when assembling the accumulator into the grommet.

LONG POST MODELS

- a. Remove front panel, *paragraph 15*.
- b. Remove two cabinet top hold-down screws and hinge cabinet top or remove, *paragraph 23*.
- c. Remove agitator hold-down cap and lift agitator out of washtub.
- d. Loosen hose clamp and disconnect filler hose from backflow preventer, then remove the eight clips holding cover to the outer tub, *Figure 35*.

NOTE: When reinstalling filler hose, white line on hose must be aligned with center line of backflow preventer, *Figure 32*.

- e. Remove cover from outer tub and set off to the side to avoid damage, then remove old gasket.

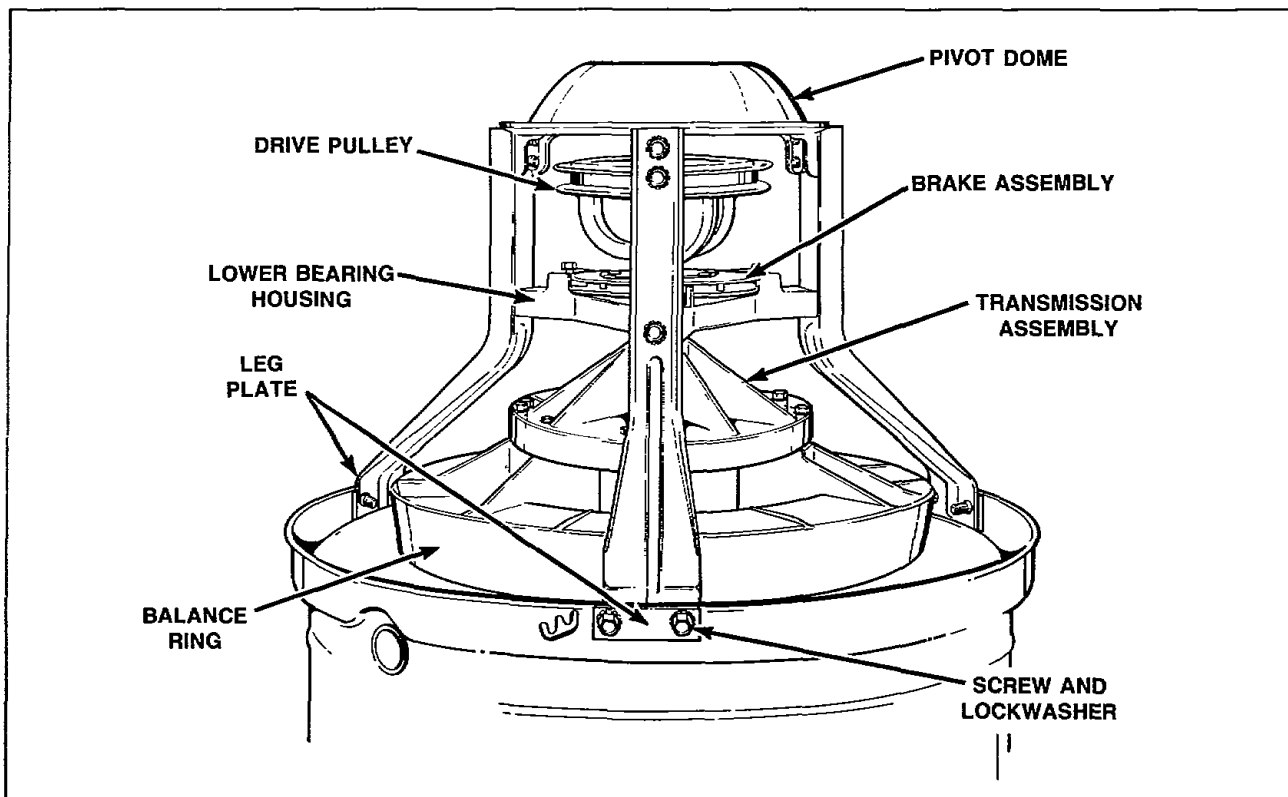

Figure 45

NOTE: When installing outer tub cover, always use a new cover gasket. Lubricate the gasket with liquid soap to aid in assembly. Cover must be placed on outer tub so notch on top edge of outer tub cover is directly over left front clip hole in tub, *Figure 35*. Starting with this hole, place each spring clip in its respective hole and snap in place. See *Figure 35* for proper clip installation.

- f. Remove four cap screws and washers holding washtub to hub, *Figure 36*.

IMPORTANT: Use caution when installing cap screws to avoid chipping porcelain on the washtub.

- g. Lift washtub (with lint filter attached) out of outer tub.

NOTE: Be sure all traces of old gasket are removed from bottom of washtub.

- h. Remove four cap screws holding agitator post to hub, *Figure 34*. Then remove assembly from hub.
- i. Straighten bent tab(s) on lockwasher, *Figure 41*, then remove hex nut using No. 237P4 Hex Wrench.
- j. Remove hub from splines on transmission tube.

NOTE: It may be necessary to use a gear puller with No. 230P4 Guide Tool, Page 27, to remove hub.

- k. Remove old seal from outer tub.

IMPORTANT: Use caution when removing old seal so as not to damage the tub flange or porcelain.

NOTE: When reinstalling or replacing outer tub, always install a new No. 365P3 Washer Seal Kit, *paragraph 28*.

- l. Reach in through front of motor mounting bracket and move idler lever to the left to release tension on belt.

IMPORTANT: Use caution when releasing the idler lever tension (and helper spring if present). If the springs are overstretched, it will affect the washer operation.

- m. While holding idler lever, reach in and around right side of motor and run belt off right side of pulley.

IMPORTANT: When removing or reinstalling the complete outer tub in to the washer (with transmission, balance ring and pivot dome attached), damage could occur to the idler lever if the idler spring is left hooked to the motor mounting bracket.

We recommend that before removing or reinstalling the complete assembly, you unhook the idler spring (and helper spring if present) and move the idler lever out of the way. This will prevent the possibility of idler lever or pulley damage.

With the idler spring hooked to the motor mounting bracket, the idler lever extends out through the rear of the bracket. When removing or reinstalling the complete tub assembly, the idler lever is in the way and can be damaged (bent), or the idler pulley could be chipped. A bent idler lever will cause misalignment of the idler pulley with the drive belt, and a chipped idler pulley will damage the belt.

- n. Using the No. 229P4 Spring Hook Tool, unhook the five centering springs from lower edge of outer tub, *Figure 46*.

IMPORTANT: When removing centering springs, mark on side of outer tub what notch the spring was hooked into. Springs must be placed in the same notch when reinstalling. Do not overstretch springs.

- o. Disconnect hoses between outer tub and pump assembly.

(continued)

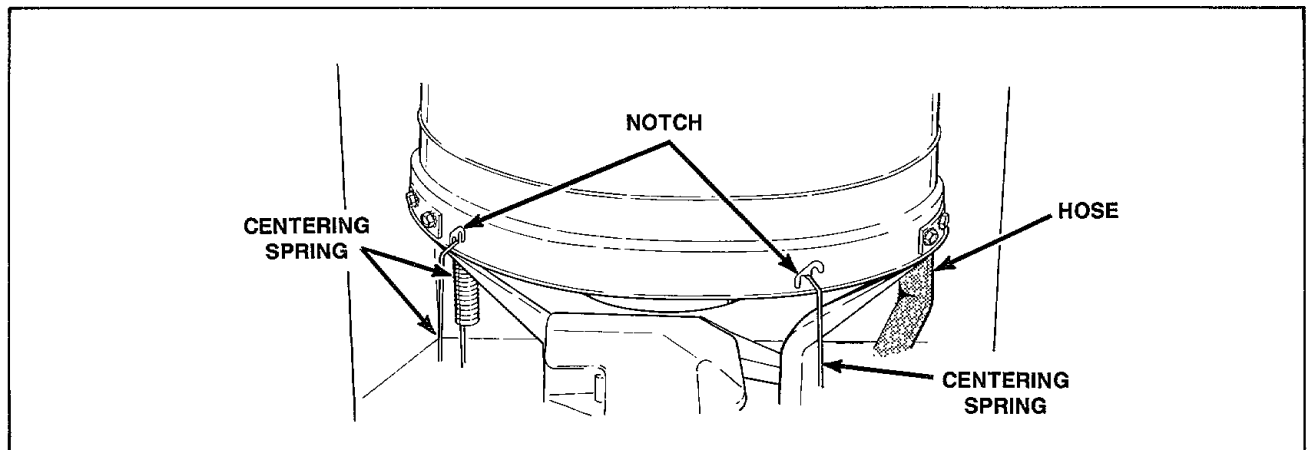

Figure 46

- p. Remove hose clamp holding pressure hose to pressure accumulator. Then remove tape holding pressure hose to outer tub.
- q. Grasp outer tub and lift complete tub assembly (with transmission, balance ring and pivot dome) straight up and out of washer cabinet.
- r. Turn the outer tub upside-down and set on protective padding.
- s. Remove screws and lockwashers holding each support leg to outer tub, *Figure 45*. Then lift transmission, balance ring and pivot dome off tub.

NOTE: To prevent porcelain damage, leg plates must be installed on both sides of the outer tub flange when reinstalling support legs. (The thinner plate must be installed between leg and tub flange and the thicker plate must be installed on the outside of tub flange.) Do not overtighten the screws as this could cause stripping or porcelain damage.

- t. Turn outer tub upright and remove the pressure accumulator and grommet.

NOTE: When installing the grommet into the outer tub, the thicker lip of the grommet must be installed to the outside of the tub. Lubricate the outer surface of the large opening of the accumulator with liquid soap to aid in assembling accumulator into the grommet.

30. DRIVE PULLEY AND HELIX

- a. Remove two screws from bottom edge of front panel, *Figure 20*.
- b. Pull bottom of panel away from washer until hold-down clips (located on top flange of panel) disengage from slots in cabinet top, *Figure 20*.
- c. Remove two front mounting screws and loosen the rear mounting screw holding pump and bracket to washer base, *Figure 21*. Pivot entire pump assembly toward motor to loosen belt tension.
- d. Run belt off motor pulley, then remove belt from pump assembly.

NOTE: After installing belt, adjust belt, paragraph 40.

- e. Reach in through front of motor mounting bracket and move idler lever to the left to release tension on belt.

IMPORTANT: Use caution when releasing the idler lever tension. If the idler spring, or helper spring, are overstretched, it will affect the washer operation.

- f. While holding idler lever, reach in and around right side of motor and run belt off right side of large drive pulley, *Figure 22*.
- g. Remove belt from motor pulley and pull belt out through front of motor mounting bracket.

IMPORTANT: When reinstalling belt, there is no drive belt adjustment.

- h. Disconnect motor wire harness from base wire harness at disconnect blocks, *Figure 27*.

Through Serial No. 14T76385

- 1. Remove screw holding ground wire to washer base, *Figure 23*.

⚠ CAUTION

Whenever ground wires are removed during servicing, those ground wires must be reconnected to insure that the washer is properly grounded.

- 2. Remove four screws holding motor and mounting bracket to washer base, *Figure 23*, then lift complete assembly out of washer.

NOTE: When reinstalling motor and mounting bracket, positioning tab on right side of mounting bracket must be placed in positioning hole in base. Mounting bracket must be shifted toward rear of washer to its limit of travel within the mounting bracket attaching screws.

- 3. Remove screw, washer and helix holding drive pulley to the input shaft of the transmission assembly, *Figure 47*.
- 4. Remove drive pulley by tilting right side up and slide pulley out between right front and rear tub support legs.

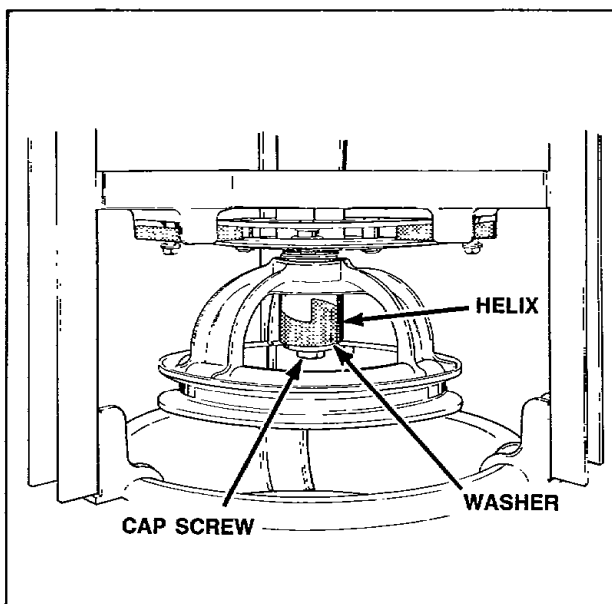

Figure 47

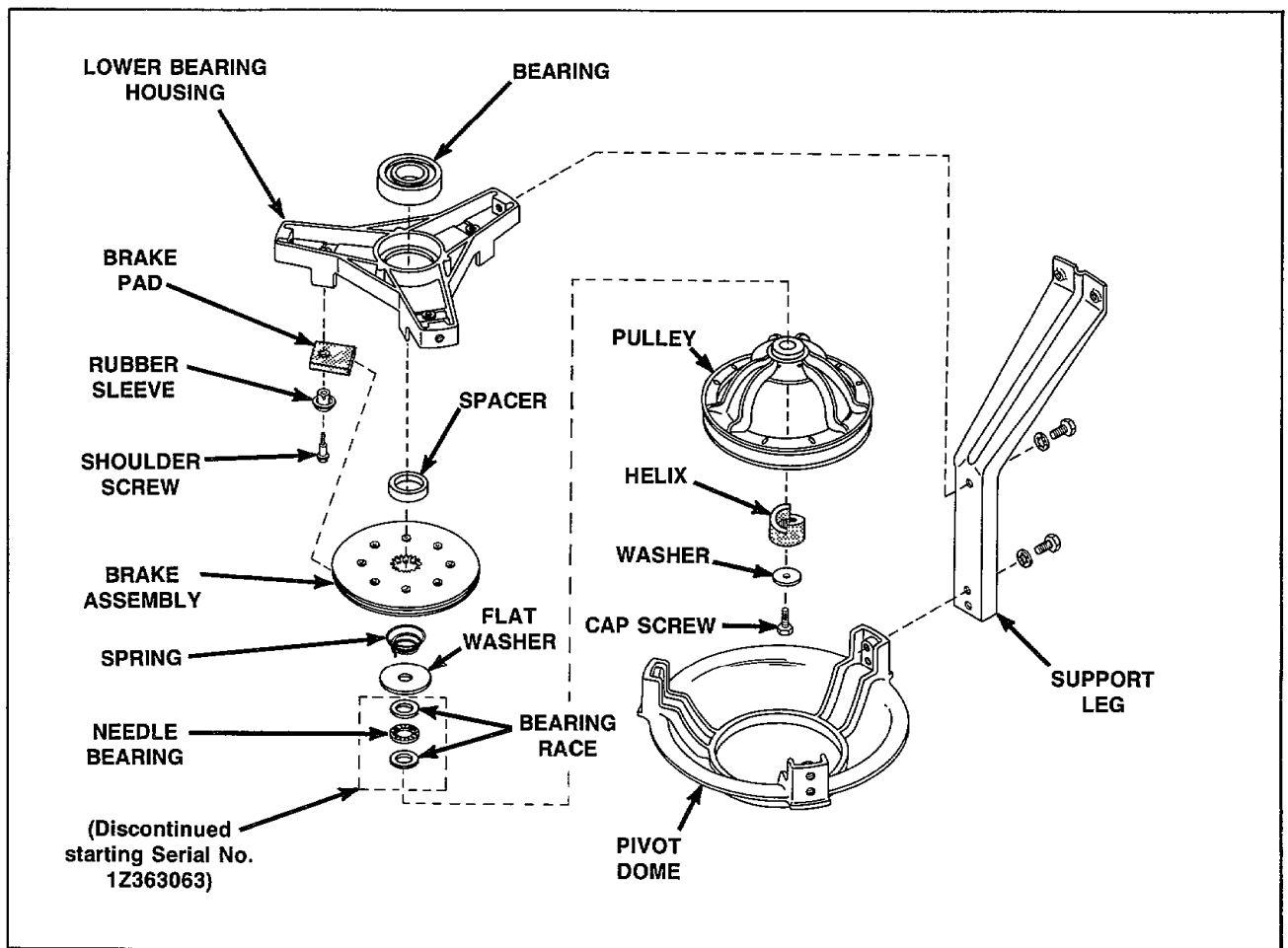

Figure 48

Through Serial No. 1Z363062

IMPORTANT: When reassembling, large flat washer, bearing race, needle bearing and bearing race must be in place, see *Figure 48* for assembly sequence.

Starting Serial No. 1Z363063

IMPORTANT: Large flat washer must be in place between the spring and drive pulley when reassembling, see *Figure 48* for assembly sequence.

NOTE: When reassembling, place a small amount of No. 21814 Lubricant to the top side of the drive pulley that will be contacting the large flat washer. Lubricate the helix ramps with No. 03200 Lubricant. See *Figure 48*.

31. BRAKE ASSEMBLY

- Remove drive pulley and helix, *paragraph 30*.
- Using a right angle needle nose pliers, remove spring from around lower transmission tube (located inside brake assembly), *Figure 48*.

NOTE: Remove spring by turning in a counter-clockwise direction (looking from lower end of input shaft of transmission assembly).

- Remove three screws holding brake pads, rubber sleeves and brake assembly to lower bearing housing, *Figure 48*, then remove brake assembly, pads and spacer off bottom of transmission assembly.

IMPORTANT: When reinstalling brake assembly, we recommend replacing the three brake pads. DO NOT replace only the worn pads. Apply a small amount of No. 26594P Silicone Lubricant to both sides of each brake pad where it will contact the brake assembly.

NOTE: Refer to *Figure 48* for assembly sequence.

IMPORTANT: When installing spring, be sure it is inserted into groove in large splines of lower transmission tube. Use tool, No. 242P4, for installing spring.

32. LOWER BEARING HOUSING

- a. Remove two screws from bottom edge of front panel, *Figure 20*.
- b. Pull bottom of panel away from washer until hold-down clips (located on top flange of panel) disengage from slots in cabinet top, *Figure 20*.
- c. Remove two cabinet top hold-down screws, and hinge cabinet top or remove, *paragraph 23*.
- d. Remove agitator hold-down cap (Long Post Models only) and remove agitator, *paragraph 11 or 13*.
- e. Disconnect filler hose from backflow preventer, *Figure 32*.

NOTE: When reinstalling filler hose, white line on hose must be aligned with center line of backflow preventer, *Figure 32*.

- f. Reach in through front of motor mounting bracket and move idler lever to the left to release tension on belt.

IMPORTANT: Use caution when releasing the idler lever tension. If the idler spring (and helper spring if present) are overstretched, it will affect the washer operation.

- g. While holding idler lever, reach in and around right side of motor and run belt off right side of large pulley, *Figure 24*.
- h. Pull belt out toward front of washer.

IMPORTANT: When removing or reinstalling the complete outer tub into washer (with washtub transmission, balance ring and pivot dome attached), damage could occur to the idler lever if the idler spring and helper spring are left hooked to the motor mounting bracket.

With the idler spring (and helper spring if present) hooked to the motor mounting bracket, the idler lever extends out through the rear of the bracket. When removing or reinstalling the complete tub assembly, the idler lever is in the way and can be damaged (bent), or the idler pulley could be chipped. A bent idler lever will cause misalignment of the idler pulley with the drive belt, and a chipped idler pulley will damage the belt.

We recommend before removing or reinstalling the complete tub assembly, unhook the idler spring and helper spring, and move the idler lever out of the way. This will prevent the possibility of idler lever or pulley damage.

- i. Using the No. 229P4 Spring Hook Tool, unhook the five centering springs from the lower edge of outer tub, *Figure 46*.

IMPORTANT: When removing the centering springs, mark on side of outer tub what notch the spring was hooked into. Springs must be placed in the same notch when reinstalling. Do not over stretch springs.

- j. Disconnect hoses between outer tub and pump assembly.

⚠ CAUTION

There will always be some water that will remain in the outer tub, therefore, before removing the hoses from the pump, the hoses will have to be drained to prevent spillage.

- k. Remove hose clamp holding pressure hose to pressure accumulator and remove hose. Then remove tape holding pressure hose to outer tub.
- l. Grasp outer tub and lift tub (with washtub transmission, balance ring and pivot dome attached) straight up and out of washer cabinet.
- m. Turn complete tub assembly upside-down on protective padding.

⚠ CAUTION

When turning the complete tub assembly upside-down, be careful not to damage the out-of-balance switch trigger (located on outer tub cover).

- n. Remove screw, washer and helix holding drive pulley to transmission shaft, *Figure 47*.
- o. Remove drive pulley from transmission shaft, *Figure 47*.
- p. Remove needle bearing (if present), bearing races (if present) and large flat washer from transmission shaft, *Figure 48*.
- q. Use a right angle needle nose pliers and remove spring from around lower transmission tube (located inside brake assembly).

NOTE: Remove spring by turning in a counter-clockwise direction (looking at bottom end of shaft).

IMPORTANT: When installing spring, be sure it is inserted into groove in large splines of lower transmission tube. Use Spring Tool, No. 242P4, for installing spring.

- r. Remove three screws and rubber sleeves holding brake pads to lower bearing housing, *Figure 48*.
- s. Lift brake assembly, pads and spacer off transmission tube.
- t. Remove three screws holding lower bearing housing to tub support legs, *Figure 48*.

- u. Rotate bearing housing past legs, then carefully lift bearing housing off transmission tube.

NOTE: It may be necessary to loosen one leg from pivot dome to rotate housing. It may require tapping lightly on housing to loosen it from the transmission tube.

IMPORTANT: When installing the lower bearing housing, apply No. 27604P Anti-Sieze Compound to the area of the transmission tube that will be contacting the bearing, *Figure 49*.

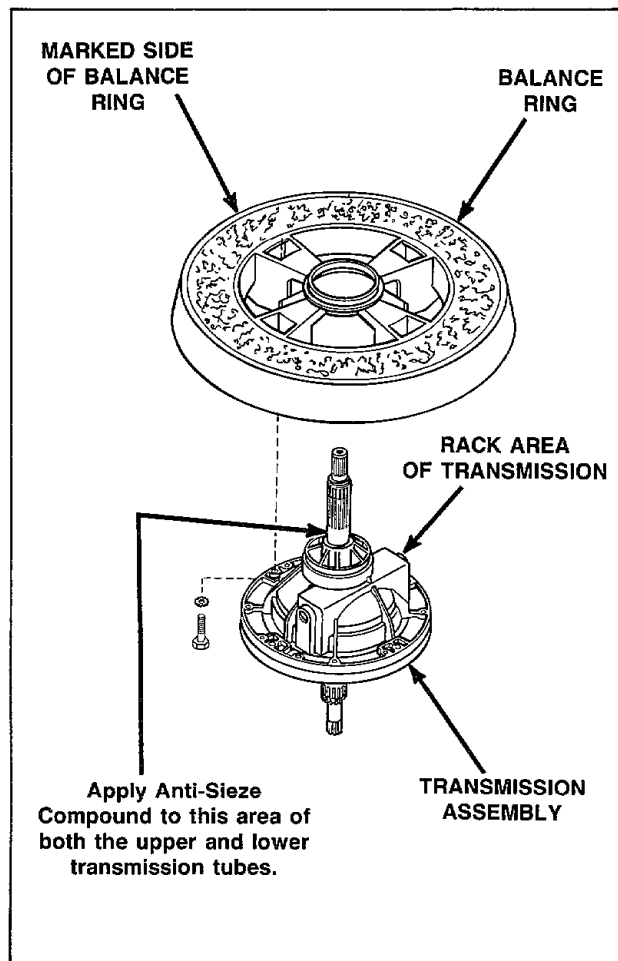

Figure 49

TO REMOVE BEARING

- a. Support the bearing housing around the outside diameter of the bearing opening and carefully press the bearing out of the housing.
- b. Clean all foreign material from inside diameter of the bearing opening.
- c. Clean any foreign material from the outside diameter of the new bearing.
- d. Apply a retaining compound (such as Loctite) to the outside diameter of the new bearing and carefully press new bearing into housing (with sealed side facing up).

IMPORTANT: Press new bearing into housing by pressing on the outer race of the bearing only, and press until bearing bottoms out in housing.

33. TRANSMISSION ASSEMBLY

- a. Remove two screws from bottom edge of front panel, *Figure 20*.
- b. Pull bottom of panel away from washer until hold-down clips (located on top flange of panel) disengage from slots in cabinet top, *Figure 20*.
- c. Remove two cabinet top hold-down screws, *Figure 29*, and hinge cabinet top or remove, *paragraph 23*.
- d. Depending on your model, follow the proper procedure for Short Post or Long Post:

Short Post Models

1. Remove agitator, *paragraph 11*.
2. Loosen hose clamp and disconnect filler hose from backflow preventer, *Figure 30*. Then remove the eight clips holding cover to outer tub, *Figure 32*.

NOTE: When reinstalling filler hose, white line on hose must be aligned with center line of backflow preventer, *Figure 30*.

3. Remove cover from outer tub and set off to the side to avoid damage, then remove old cover gasket.

NOTE: When reinstalling outer tub cover, always use a new cover gasket. Lubricate the gasket with liquid soap to aid in assembly. Cover must be placed on outer tub so notch on top edge of outer tub cover is directly over the left front clip hole in tub, *Figure 32*. Starting with this hole, place each spring clip in its respective hole and snap into place. See *Figure 32* for proper clip installation.

4. Remove four screws and washers holding washtub to hub, *Figure 31*.

IMPORTANT: Porcelain Washtub Models – Use caution when tightening screws to avoid chipping porcelain on the washtub.

5. Lift washtub and lint filter out of outer tub.

CAUTION

When removing the washtub and lint filter, **DO NOT** lift up on the lint filter as you could damage the filter. Grasp the top flange of the washtub and remove from outer tub.

(continued)

6. Remove drive bell, *paragraph 12*, steps "a" through "k".
7. Remove hex nut using No. 237P4 Hex Wrench.

NOTE: It may be necessary to use a gear puller to remove hub.

8. Continue with step "e".

Long Post Models

1. Remove agitator, *paragraph 11*.
2. Loosen hose clamp and disconnect filler hose from backflow preventer, *Figure 30*. Then remove the eight clips holding cover to outer tub, *Figure 35*.

NOTE: When reinstalling filler hose, white line on hose must be aligned with center line on backflow preventer, *Figure 30*.

3. Remove cover from outer tub and set off to the side to avoid damage, then remove old cover gasket.

NOTE: When reinstalling outer tub cover, always use a new cover gasket. Lubricate the gasket with liquid soap to aid in assembly. Cover must be placed on outer tub so notch on top edge of outer tub cover is directly over the left front clip hole in tub, *Figure 35*. Starting with this hole, place each spring clip in its respective hole and snap into place. See *Figure 35* for proper clip installation.

4. Remove four screws and washers holding washtub to hub, *Figure 36*.

IMPORTANT: Porcelain Washtub Models – Use caution when tightening screws to avoid chipping porcelain on the washtub.

5. Lift washtub and lint filter out of outer tub.

▲ CAUTION

When removing the washtub and lint filter, **DO NOT** lift up on the lint filter as you could damage the filter. Grasp the top flange of the washtub and remove from outer tub.

6. Remove four cap screws holding agitator post to hub, *Figure 17*, and remove assembly from hub.
7. Straighten bent tab(s) on lockwasher, *Figure 41*, then remove hex nut using No. 237P4 Hex Wrench.
8. Remove hub from splines on transmission tube.

NOTE: It may be necessary to use a gear puller to remove hub.

9. Continue with step "e".

- e. Remove the old water seal from the outer tub.

IMPORTANT: Use caution when removing the old water seal so as not to damage the tub flange or porcelain.

NOTE: When reinstalling or replacing the outer tub, we recommend installing a new No. 441P3 Water Seal Kit, *paragraph 27*.

- f. Reach in through front of motor mounting bracket and move idler lever to the left to release tension on belt.

IMPORTANT: Use caution when releasing the idler lever tension. If the idler spring and helper spring are overstretched, it will affect the washer operation.

- g. While holding idler lever, reach in and around right side of motor and run belt off right side of large drive pulley.

IMPORTANT: When removing or reinstalling the complete outer tub into the washer (with transmission, balance ring and pivot dome attached), damage could occur to the idler lever if the idler spring (and helper spring if present) are left hooked to the motor mounting bracket.

With the idler spring (and helper spring if present) hooked to the motor mounting bracket, the idler lever extends out through the rear of the bracket. When removing or reinstalling the complete tub assembly, the idler lever is in the way and can be damaged (bent), or the idler pulley could be chipped. A bent idler lever will cause misalignment of the idler pulley with the drive belt, and a chipped pulley will damage the belt.

We recommend before removing or reinstalling the complete assembly, unhook the idler spring and helper spring and move the idler lever out of the way. This will prevent the possibility of idler lever or pulley damage.

- h. Using the No. 229P4 Spring Hook Tool, unhook the five centering springs from lower edge of outer tub, *Figure 44*.

IMPORTANT: When removing the centering springs, mark on side of outer tub what notch the spring was hooked into. Springs must be placed in same notch when reinstalling. Do not overstretch springs. Mark the word "FRONT" on the front side of the outer tub so the complete tub module can be reinstalled in the same position.

- i. Disconnect hoses between outer tub and pump assembly.

- q. Lift transmission assembly straight up and out of balance ring and upper bearing.

▲ CAUTION

There will always be some water that will remain in the outer tub, therefore, before removing hoses from the pump, the hoses will have to be drained to prevent water spillage on the floor.

- j. Loosen hose clamp holding pressure hose to pressure accumulator and remove hose. Then remove tape holding pressure hose to outer tub.
- k. Grasp outer tub and lift complete tub assembly (with transmission, balance ring and pivot dome attached) straight up and out of washer cabinet.
- l. Turn the outer tub upside-down and set on protective padding.
- m. Remove screw, washer and helix holding drive pulley to transmission shaft. Then remove drive pulley, needle bearing, bearing races (if present) and large flat washer from transmission.
- n. Using a right angle needle nose pliers, remove spring from around lower transmission tube (located inside brake assembly).

NOTE: Remove spring by turning in a counter-clockwise direction (looking at bottom end of shaft).

IMPORTANT: When reinstalling spring, be sure it is inserted into groove in large spline of transmission tube. Use Spring Tool, No. 242P4, when installing spring.

- o. Remove screws and lockwashers holding each support leg to outer tub, *Figure 45*, then lift pivot dome, brake assembly and lower bearing housing off transmission tube.

NOTE: It may be necessary to tap lightly on bearing housing to loosen it from the transmission tube.

IMPORTANT: When installing the lower bearing housing pivot dome and brake assembly, apply No. 27604P Anti-Sieze Compound to the area of the transmission tube that will be contacting the bearing, *Figure 49*.

To prevent porcelain damage, leg plates must be installed on both sides of outer tub flange when reinstalling support legs. (The thinner plate must be installed between leg and tub flange and the thicker plate must be installed on the outside of tub flange.) Do not overtighten the screws as this could cause stripping or porcelain damage.

- p. Remove four screws and lockwashers holding transmission assembly to balance ring.

IMPORTANT: When replacing or reinstalling the transmission assembly, it is important that No. 27604P Anti-Sieze Compound be applied to the area of the transmission tubes where they will be contacting the upper and lower bearings, *Figure 50*.

When reinstalling the transmission assembly, note there is a mark located on the outer edge of the balance ring. This mark indicates the heavy side of ring. This heavy side must be installed opposite the rack of the transmission assembly, *Figure 49*. Carefully lower transmission through balance ring and upper bearing. **DO NOT DROP OR LOWER TRANSMISSION ASSEMBLY INTO POSITION TOO HARD** as this can cause the bearing to move within the bearing housing which will cause vibration, noise, wear or no spin.

TO DISASSEMBLE TRANSMISSION ASSEMBLY (Depending on your model, refer to *Figure 50, 51, or 52* for assembly sequence)

- a. Place the transmission in a vice with the input shaft end up. Clamp only the case, not the shaft.

NOTE: Supporting the transmission in this manner will allow the oil to collect in the transmission case.

- b. Before disassembling the transmission halves, mark the outer edge of the transmission case and cover so the two can be reassembled in the same position.
- c. Place the transmission in the vice so three of the eight screws holding the transmission case and cover together are in the 12, 4 and 7 o'clock positions.
- d. Loosen the three screws, mentioned in step "c", approximately two turns. **DO NOT** remove these three screws at this time. Remove the remaining five screws and lockwashers completely.
- e. Remove the transmission assembly from the vice.
- f. While holding the transmission by the cover end, gently tap each of the three remaining screws until the two halves separate. Place assembly back into vice (cover end up) and remove the three screws and lockwashers.
- g. Remove the reduction gear from the transmission cover.

NOTE: Remove the screw and washer holding the reduction gear to the transmission cover.

(continued on Page 63)

SHORT POST MODELS

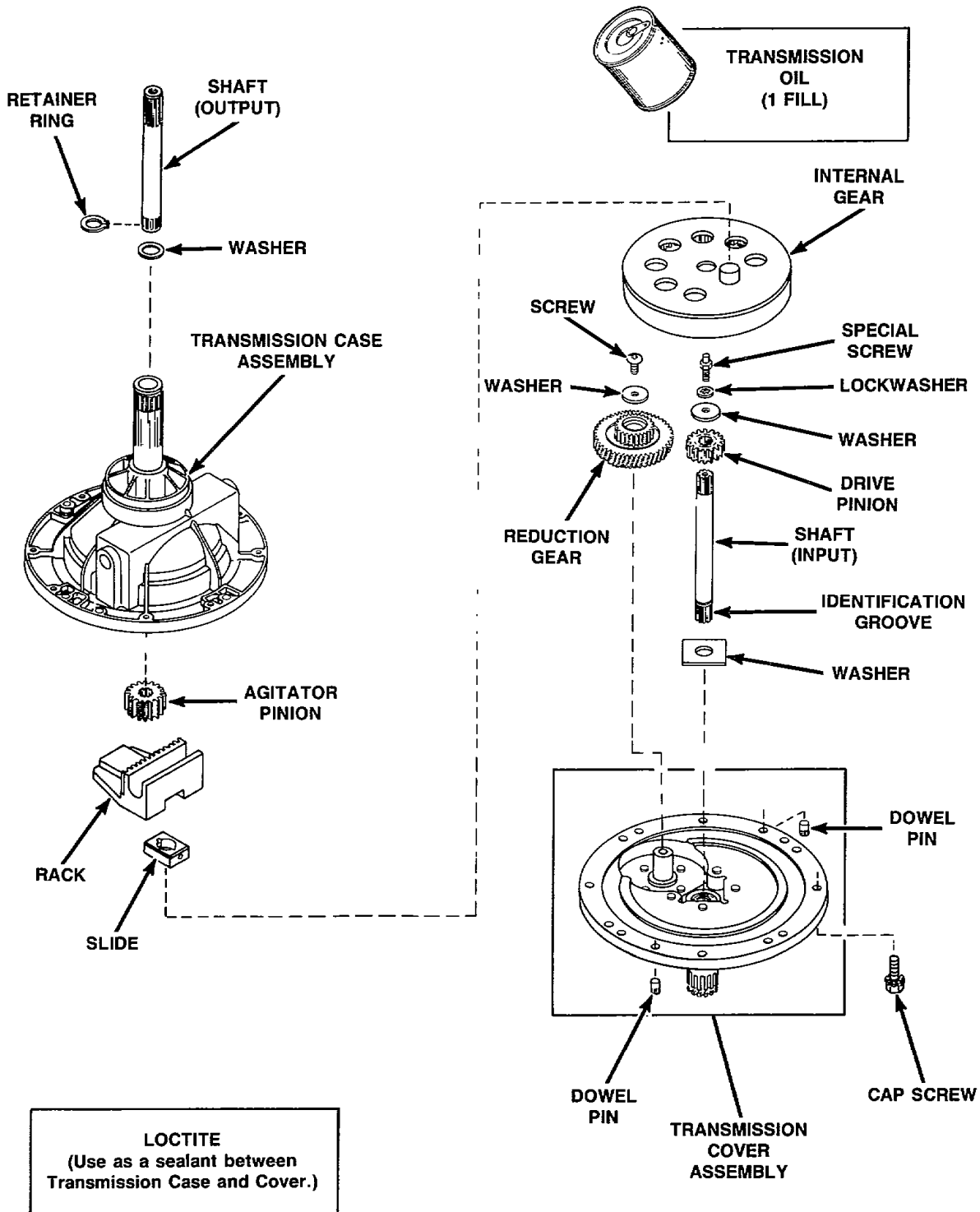

Figure 50

**LONG POST MODELS
(Through Serial No. 1M295983)**

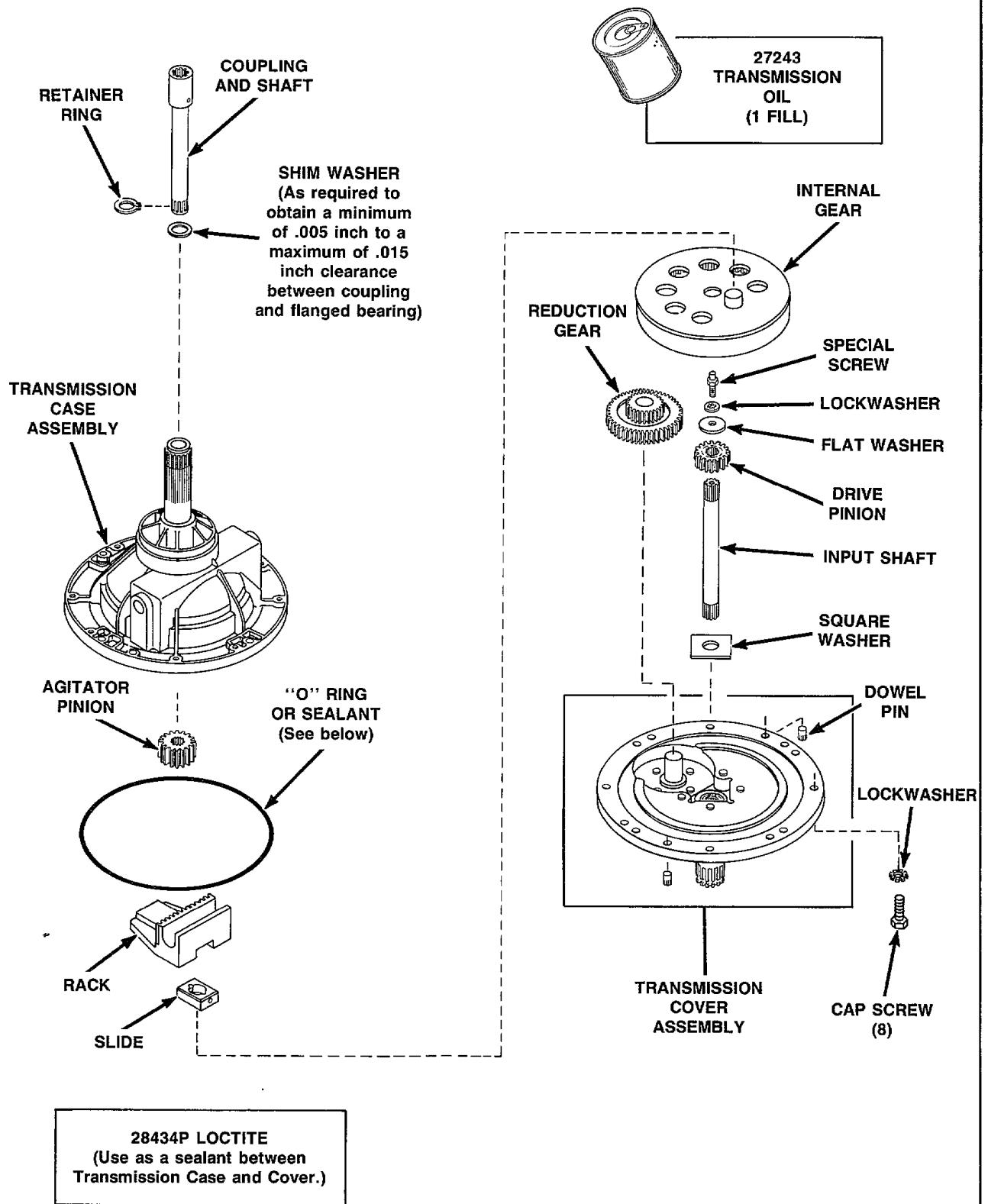

Figure 51

LONG POST MODELS
 (Starting Serial No. 1M295984)

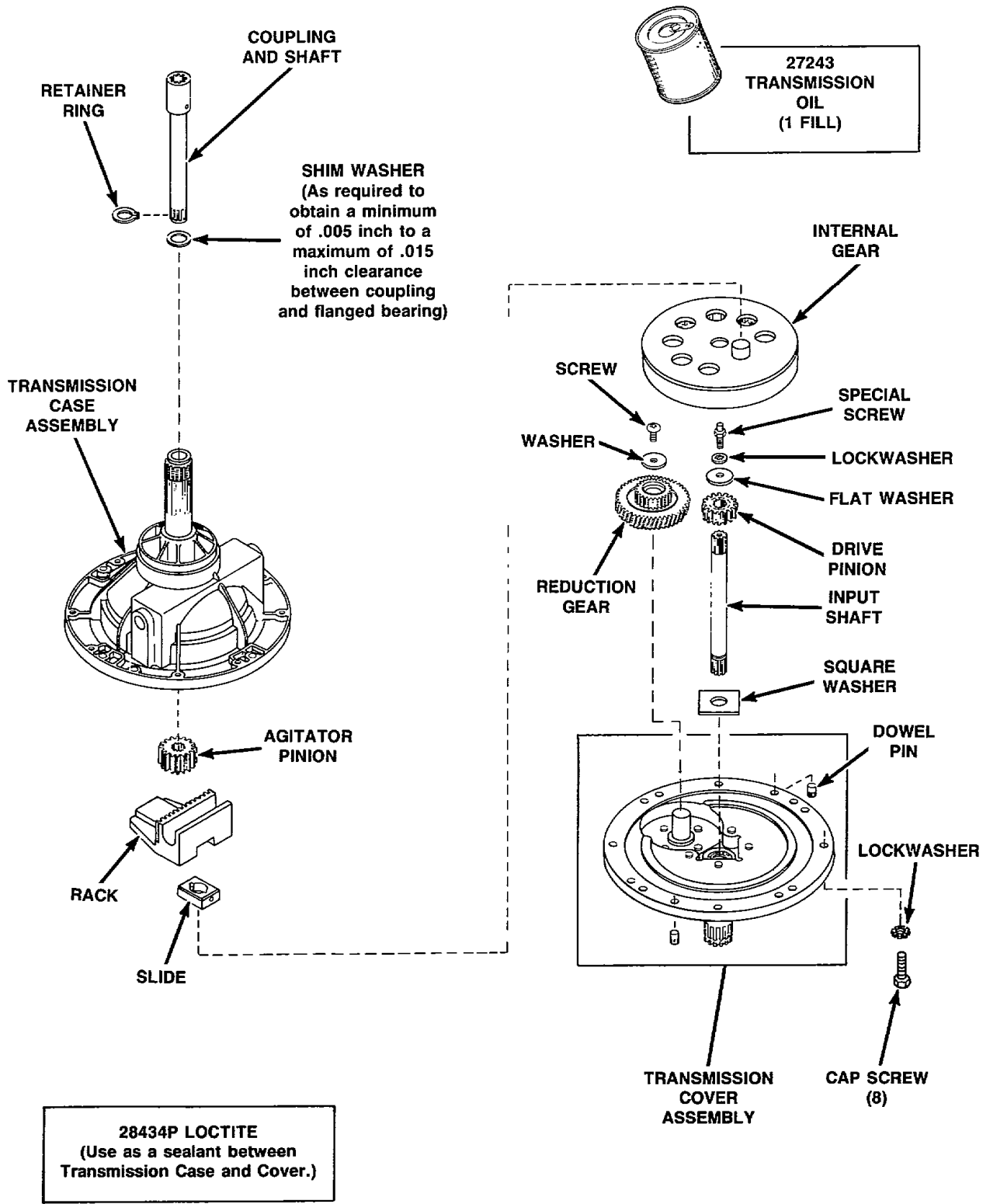

Figure 52

- h. Remove the special screw, lockwasher and flat washer holding the drive pinion to the input shaft.

NOTE: To prevent the input shaft from turning during the removal of the special screw, place a helix onto the shaft and hold the helix with a locking pliers.

- i. Remove the drive pinion from the input shaft using a hammer and punch to drive the shaft out of the pinion.
- j. Remove the input shaft and square washer from the transmission cover.

IMPORTANT: Carefully examine the area inside the cover tube (seals, bearing, roller clutch, etc.). If oil is present between the seals and bearing, or the roller clutch is bad, it will require replacing the complete transmission cover assembly. The individual components are not available separately.

- k. Remove the internal gear, slide and rack from the transmission case.
- l. Remove the transmission case from the vice and drain the oil.
- m. Remove the retainer ring from the output shaft.
- n. Using a hammer and punch, carefully drive the shaft out of the agitator pinion.
- o. Carefully remove output shaft and washers from the transmission case.

IMPORTANT: Carefully examine the area inside the transmission case tube (seals, bearings, etc.). If oil is present between the seals and bearings, it will require replacing the complete transmission case. The seals and bearings are not available separately.

TO REASSEMBLE TRANSMISSION ASSEMBLY

IMPORTANT: Wash all the individual components in a cleaning solution (mineral spirits). Wipe the inside of the transmission case and cover with a clean cloth, dampened with cleaning solution, to remove any impurities. DO NOT allow the cleaning solution to come in contact with the bearings and seals in the transmission case and/or cover.

Short Post Models

Place washer over shaft and carefully insert output shaft into the transmission case.

Long Post Models

Carefully insert output shaft and coupling into the transmission case.

NOTE: If a new shaft and coupling are installed, then you will have to use shim washers as required to obtain a minimum clearance of .005 inch (.015 inch maximum) between the flanged bearing and coupling on output shaft. Shaft must be free to rotate.

- a. Place agitator pinion on splines of output shaft and press onto shaft.
- b. Install retainer ring on output shaft.
- c. Place the transmission case into a vice. Clamp only the case, not the shaft.
- d. Place the rack inside the transmission case with the rack resting on the bar in the case. Agitator pinion must engage the rack.

NOTE: Put a light film of transmission oil on the bar where the rack will slide back and forth.

- e. Position the slide in the slot on the rack.

NOTE: Put a light film of transmission oil in the slot on the rack, also, transmission oil should be put in the track of the transmission case where the internal gear will ride.

- f. Place the internal gear into the transmission case. Make sure the guide pin on the internal gear fits in the hole on the side.

IMPORTANT: Never install a used internal gear in a new transmission case. If transmission case and the internal gear are to be reused, be sure they are used as the original set.

- g. Refill transmission case with new No. 27243 Transmission Oil (one fill).
- h. To prevent seal damage, insert the input shaft into the cover starting at the outer end of the cover tube.

IMPORTANT: Short Post Models – End of shaft with identification groove, Figure 50, must be facing outward. This is the end that will mate with the helix.

- i. Place the square washer over shaft and into position in the cover.
- j. Install the drive pinion, flat washer, lockwasher and special screw onto the input shaft.

NOTE: Use thread locking compound on the threads of the special screw to prevent screw from loosening.

IMPORTANT: Be sure the mating surfaces of the transmission cover and case are free of oil or any other foreign material.

- k. Place the reduction gear on the stub shaft of the cover and install screw and washer.

(continued)

NOTE: Use thread locking compound on the threads of the special screw to prevent screw from loosening.

- i. Apply a bead of sealant, No. 28434P Loctite, on the mating surface of the transmission case.

IMPORTANT: The bead of sealant should be no more than 1/16 inch in diameter. **DO NOT** allow any of the sealant to get in contact with the edges of the internal gear (sealer may damage moving parts).

- m. Carefully place the transmission cover over top of the transmission case. Make sure the holes in the cover line up with the holes in the case, and the marked edges of the two halves are aligned.
- n. Carefully lower the cover onto the case.
- o. Secure the two transmission halves together using the eight screws removed during disassembly. Tighten the eight screws evenly.
- p. Remove the complete transmission assembly from the vice.
- q. Apply Anti-Sieze Compound, No. 27604P, to the smooth area of both transmission tubes that will be contacting the upper and lower bearings.

34. BALANCE RING

- a. Remove transmission assembly, *paragraph 33*, steps "a" through "q".
- b. Lift balance ring off outer tub.

IMPORTANT: When reinstalling the balance ring, note there is a mark located on the outer edge of the balance ring. This mark indicates the heavy side of ring. This heavy side must be installed opposite the rack of the transmission assembly, *Figure 49*.

35. UPPER BEARING ASSEMBLY

- a. Remove transmission assembly, *paragraph 33*, steps "a" through "q".
- b. Remove screws and lockwashers holding each support leg to outer tub, *Figure 45*. Lift complete pivot dome (with drive pulley, brake assembly, lower bearing housing, transmission assembly and balance ring attached) off outer tub.

IMPORTANT: To prevent porcelain damage, leg plates must be installed on both sides of outer tub flange when reinstalling support legs. (The thinner plate must be installed between leg and tub flange and the thicker plate must be installed on the outside of tub flange.) Do not overtighten screws as this could cause stripping or porcelain damage.

- c. Remove three screws holding upper bearing and housing to bottom of outer tub, *Figure 53*.

NOTE: Replace bearing and housing as an assembly, and be sure flinger is properly positioned between the outer tub and bearing assembly, *Figure 53*.

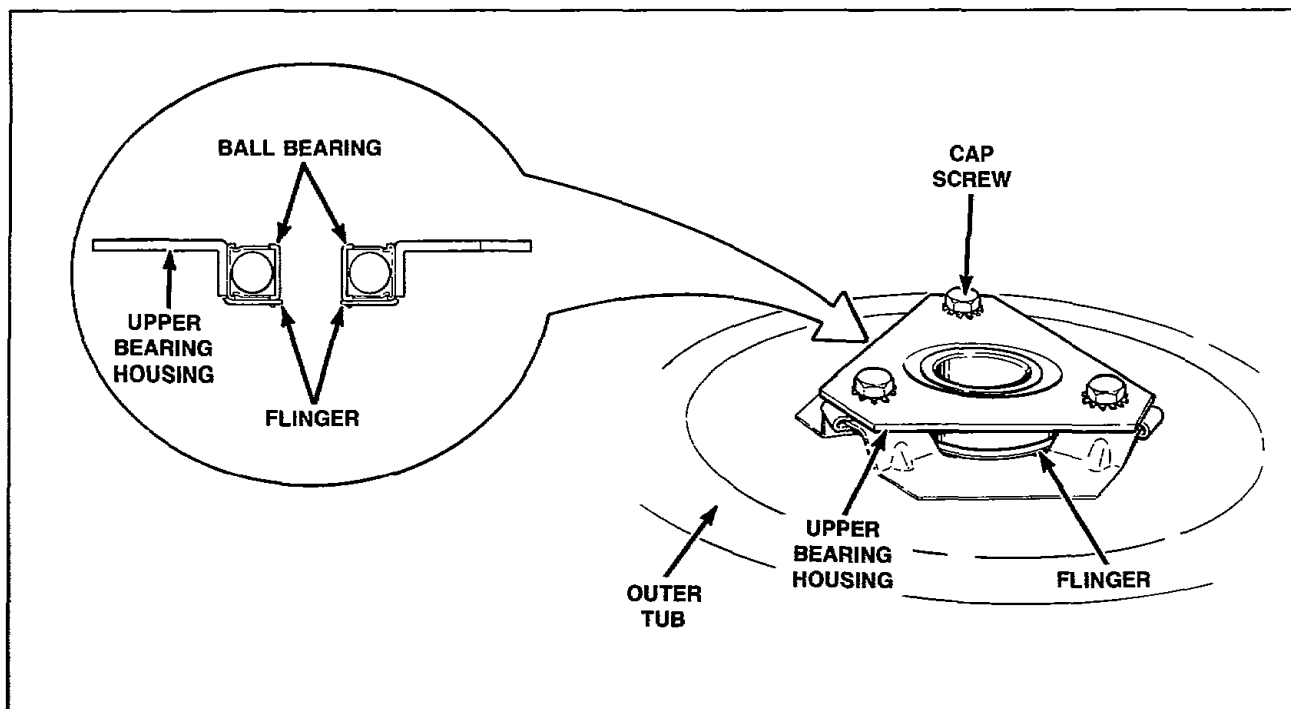

Figure 53

36. SNUBBER PADS

- Remove transmission assembly, *paragraph 33*, steps "a" through "k".
- Scrape the old snubber pads from the washer base.
- Thoroughly clean the area of the base where the new snubber pads will be installed.

NOTE: Use a cleaning agent, such as lacquer thinner, for removing grease, old adhesive, or any foreign materials from the base.

TO INSTALL NO. 434P3 SNUBBER PAD KIT

- Brush approximately 3/4 inch wide strip of No. 22506P Adhesive to the dome area of the base where the new pads will be applied.

⚠ WARNING

Do not allow any of the adhesive to get on the surface of the new pads that will be contacting the pivot dome of the tub module.

- Carefully align and apply the new snubber pads (with fluffed side up) to the base dome so they are equally spaced, *Figure 54*.

IMPORTANT: The top edge of the snubber pads should be 1-7/16 inches from the lower part of the dome with a distance of 1/16 inch between the pads, *Figure 54*.

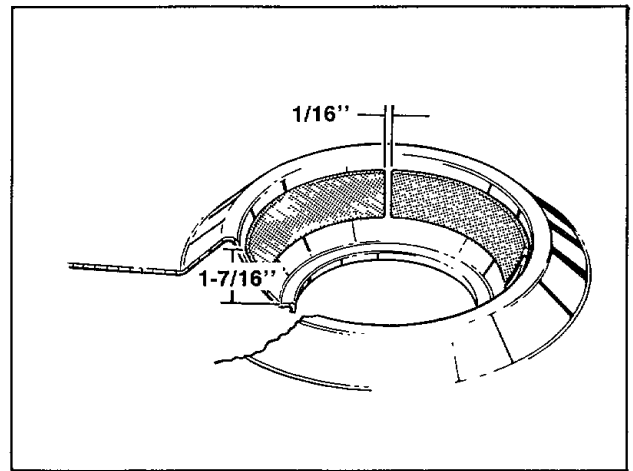

Figure 54

⚠ WARNING

Before proceeding, allow the pads to adhere to the base for approximately 30 minutes.

- Apply a liberal amount of No. 26594P Silicone Lubricant to the surface of the new pads that will contact the pivot dome.
- Carefully place the tub module back into washer making sure the pivot dome is positioned properly in dome recess of the washer base, *Figure 55*.

NOTE: Be sure the word "FRONT" (on outer tub) is facing toward front of washer.

(continued)

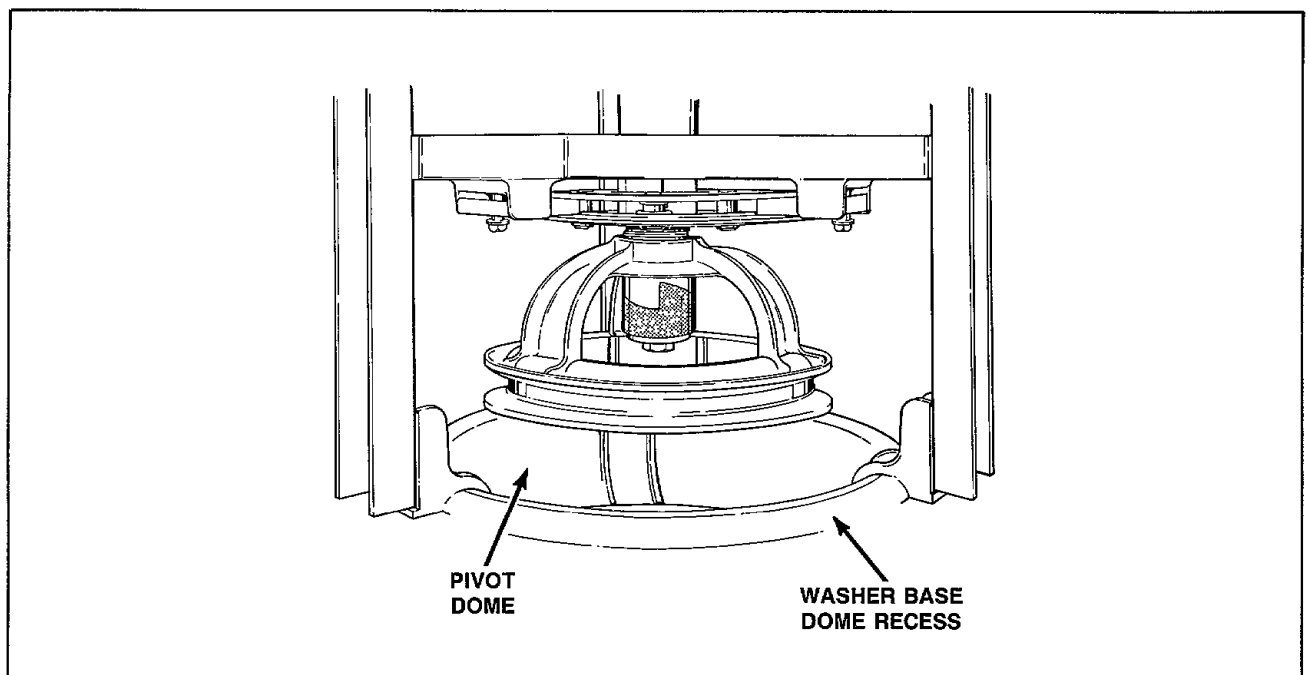

Figure 55

- e. Use the No. 229P4 Spring Hook Tool and hook the five centering springs into the lower edge of the outer tub, starting with the rear springs.

NOTE: Springs must be hooked into the center of the three notches, Figure 56.

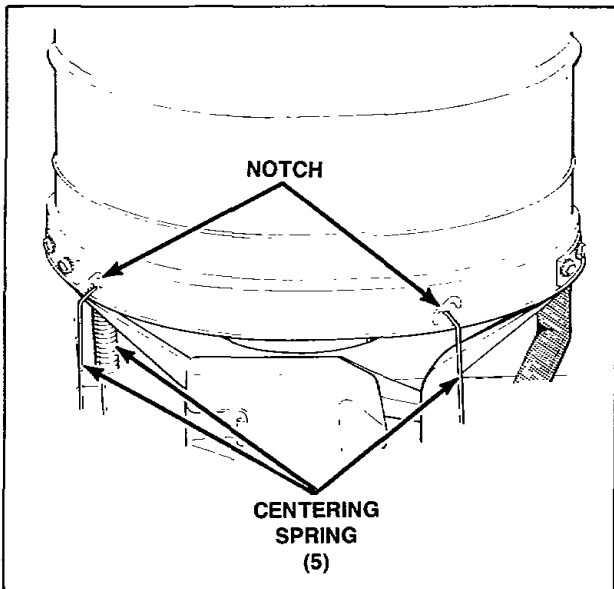

Figure 56

- f. Connect the hose from the outer tub to the pump and tighten hose clamp.
- g. Reconnect idler spring to clip on motor mounting bracket, and helper spring into the back hole in the mounting bracket, Figure 57.
- h. Place drive belt on motor pulley, reach around right side of motor, starting with belt on right side of large pulley, run belt onto large pulley.
- i. Route the pressure hose through the wire harness clips, Figure 30. Then route pressure hose back up through hole in cabinet top.
- j. Reconnect the filler hose to the backflow preventer, Figure 30.

NOTE: When installing filler hose, white line on hose must be aligned with center line of backflow preventer, Figure 30. Hose clamp must be positioned as shown in Figure 30 so it will not interfere with the cabinet top.

- k. Reinstall cabinet top.
- l. Remove control hood, reconnect pressure hose to pressure switch. Then reinstall control hood.
- m. Reinstall washer front panel.
- n. Reconnect washer power cord and open water supply valves.

NOTE: The washer must be run through a complete cycle to make sure it is operating properly.

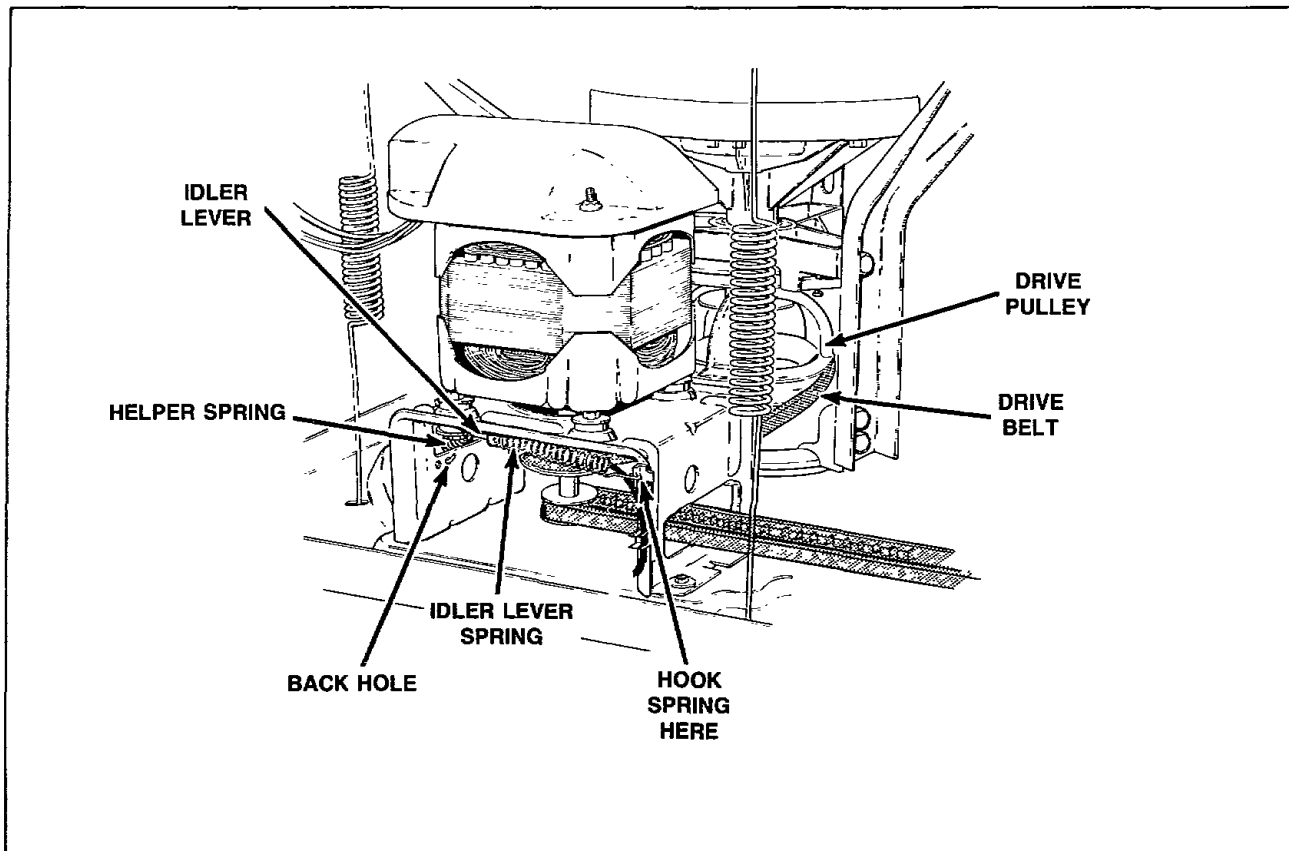

Figure 57

SECTION III

Adjustments

37. LEVELING LEGS (Refer to Figure 58)

- Loosen locknuts and thread leveling legs into washer base as far as possible.
- Turn appropriate leveling leg(s) out of base only until washer is level. Keep washer as close to floor as possible.
- Install rubber pads over leveling legs.

IMPORTANT: All four legs must rest firmly on floor so weight of washer is evenly distributed. Washer must not rock.

- Tighten locknuts securely against bottom of washer base after washer has been leveled.

NOTE: Washer should be installed on a reasonably firm floor. The flexing of a weak floor may cause excessive vibration. Vibration can also be caused if the washer is installed on carpeting or a vinyl floor.

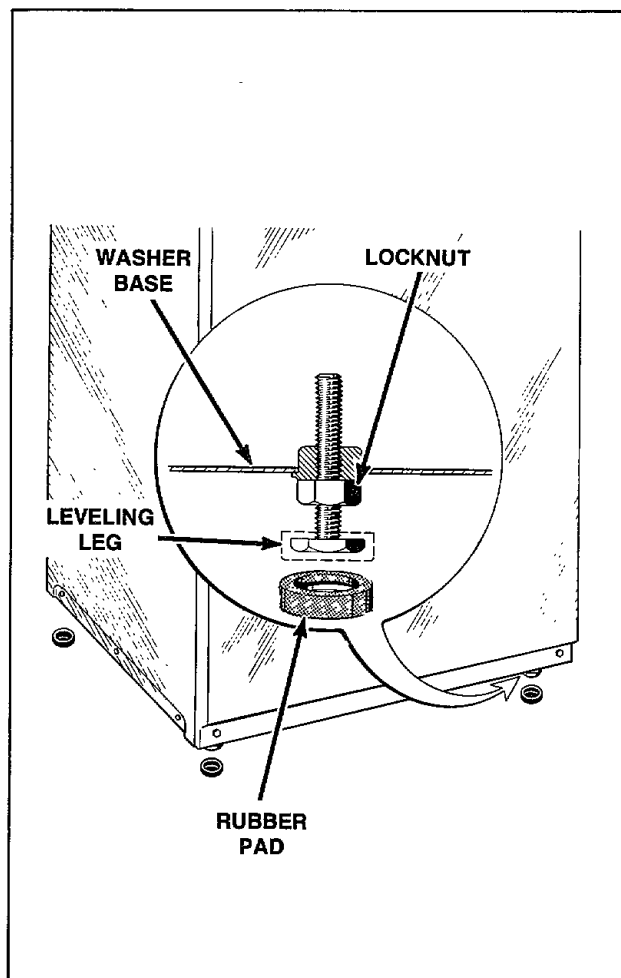

Figure 58

IMPORTANT: DO NOT move washer at any time unless locknuts are securely tightened and the styrofoam shipping brace is in place over the agitator (to prevent damage to washer components). DO NOT slide washer across floor once the leveling legs have been extended, as legs and base could become damaged.

38. PRESSURE SWITCH (Refer to Figure 59)

NOTE: DO NOT ADJUST PRESSURE SWITCH IF WASHER IS WITHIN THE WARRANTY PERIOD.

The pressure switch on pressure-fill automatic washers is set at the factory for proper water fill levels. However, if there is a problem of overfilling or underfilling, the pressure switch can be adjusted in the field.

The maximum water fill level can be increased by turning adjusting screw clockwise, or decreased by turning screw counterclockwise. Each 1/4 turn of adjusting screw represents approximately one inch (2.54 cm) increase or decrease of water level in tub.

IMPORTANT: DO NOT turn adjusting screw more than 3/4 of a turn in either direction.

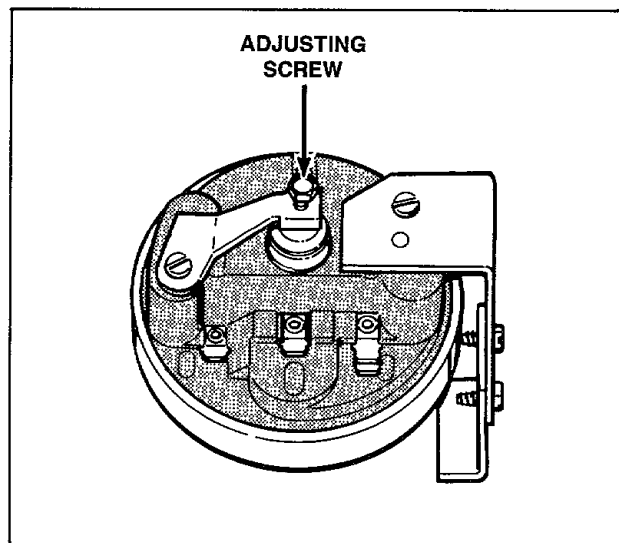

Figure 59

39. BELT - Agitate and Spin

No belt adjustment is required.

NOTE: When motor is installed in washer, motor and mounting bracket must be shifted toward rear of washer to its limit of travel within the mounting bracket attaching screws.

40. BELT (Pump)

NOTE: Adjustment must be made after motor has been properly positioned, see *paragraph 39*.

- a. Remove front panel, *paragraph 15*.
- b. Loosen the two front mounting screws, *Figure 60*, then loosen the rear screw.
- c. Shift front of pump mounting bracket to the right or left to obtain proper belt tension. Proper tension is when belt can be deflected approximately 1/2 inch (12.7 mm) from its normal position by applying moderate pressure (1-1/2 pounds - .675 kg.) to a point midway between pulleys, *Figure 61*.
- d. After belt tension is obtained, tighten the three pump mounting bracket screws.

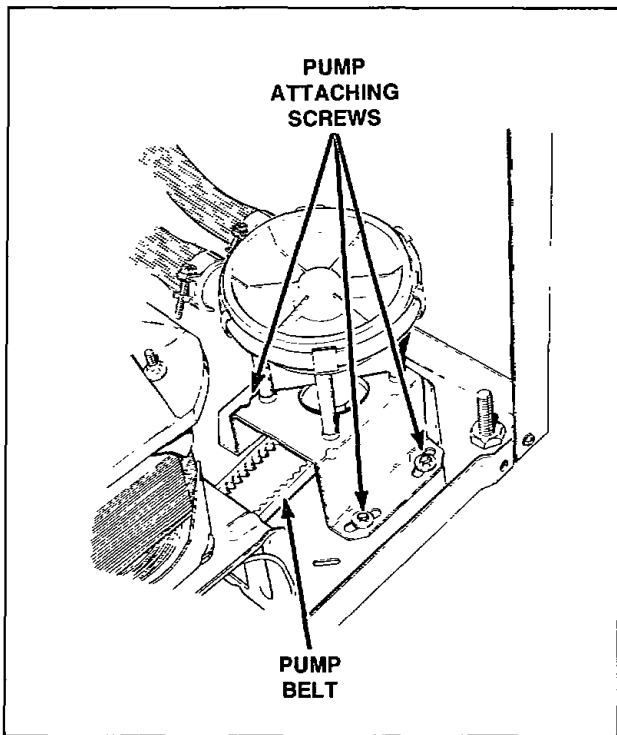

Figure 60

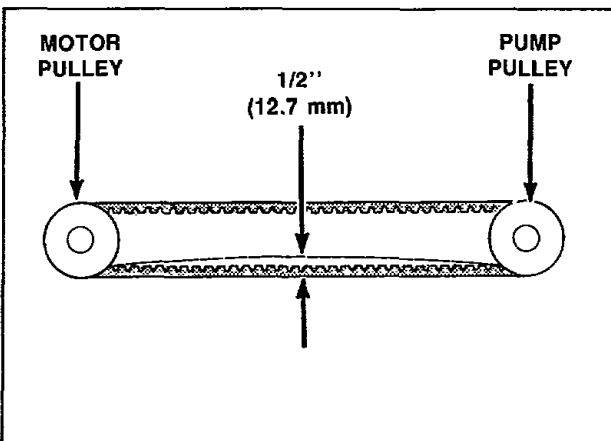

Figure 61

41. OUT-OF-BALANCE SWITCH TRIGGER

NOTE: The trigger is centered on the mounting screw at the factory, *Figure 62*.

- a. Remove front panel, *paragraph 15*.
- b. Raise or remove cabinet top, *paragraph 23*.
- c. Loosen screw holding trigger to tub cover, *Figure 62*, move trigger to the right (increases sensitivity) or to the left (decreases sensitivity).

IMPORTANT: If the trigger repeatedly trips the out-of-balance switch lever, check the centering of the agitator within the loading door opening. Centering springs may have to be repositioned in the upper or lower notch (positioned in center notch at factory, *Figure 63*), to center the agitator within the door opening.

Example: If the springs are placed in the upper notch, then the trigger must be moved to the extreme right for proper trigger operation.

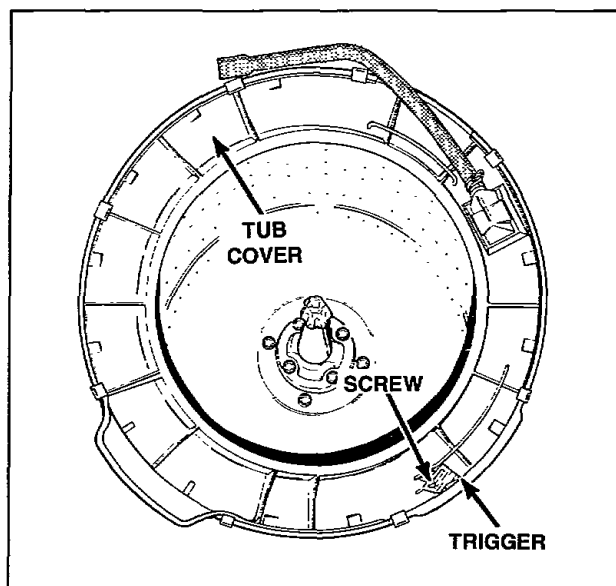

Figure 62

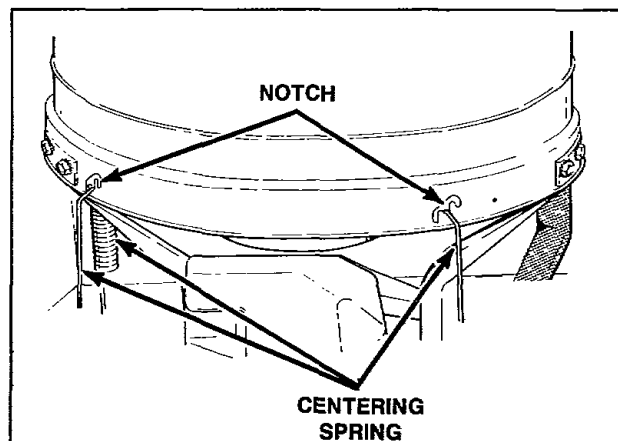

Figure 63

SECTION IV

Service Helps

IMPORTANT: Refer to appropriate Wiring Diagram for aid in testing washer components.

42. NO HOT WATER

POSSIBLE CAUSE	TO CORRECT
Hot water supply valve is closed.	Open valve.
Water supply is cold.	Check water heater.
Kinked hot water inlet hose.	Straighten or replace hose.
Clogged mixing valve screen, or screen in outer end of inlet hose nearest water supply faucet.	Disconnect hot water inlet hose, and clean or replace screen.
Inoperative hot water mixing valve solenoid.	Test solenoid and replace if inoperative.
Inoperative timer.	Test timer and replace if inoperative.
Inoperative temperature switch.	Test switch and replace if inoperative.
Inoperative pressure switch.	Test switch and replace if inoperative.
Clogged pressure hose.	Remove and clean or replace hose.
Broken, loose, or incorrect wiring.	Refer to appropriate Wiring Diagram.

43. NO COLD WATER

POSSIBLE CAUSE	TO CORRECT
Cold water supply valve is closed.	Open valve.
Kinked cold water inlet hose.	Straighten or replace hose.
Clogged mixing valve screen, or screen in outer end of inlet hose nearest water supply faucet.	Disconnect cold water inlet hose, and clean or replace screen.
Inoperative cold water mixing valve solenoid.	Test solenoid and replace if inoperative.
Inoperative timer.	Test timer and replace if inoperative.
Inoperative temperature switch.	Test switch and replace if inoperative.
Inoperative pressure switch.	Test switch and replace if inoperative.
Clogged pressure hose.	Remove and clean or replace hose.
Broken, loose, or incorrect wiring.	Refer to appropriate Wiring Diagram.

44. NO WARM WATER

POSSIBLE CAUSE	TO CORRECT
No hot water.	Refer to <i>paragraph 42</i> .
No cold water.	Refer to <i>paragraph 43</i> .

45. WATER FILL DOES NOT STOP AT PROPER LEVEL

POSSIBLE CAUSE	TO CORRECT
Inoperative pressure switch.	Test switch and replace if inoperative.
Air leak in pressure hose.	Replace hose.
Sediment on or under mixing valve diaphragm, defective diaphragm, or armature binding in armature guide.	Disassemble and clean mixing valve. Replace deteriorated or not easily cleaned components. Refer to Parts Section in this manual for assembly sequence of valve.
Broken, weak or missing mixing valve armature spring.	Disassemble valve and replace spring. Refer to Parts Section in this manual for assembly sequence of valve.
A siphoning action started in washer will cause water to be siphoned from the washer during the cycle due to the end of the drain hose being lower than cabinet top of washer. Drain hose fits tight in standpipe or drain.	Install No. 386P3 Siphon Break Kit. Provide an air gap around drain hose and drain receptacle.
Water in pressure hose.	Blow air through hose to remove water.
Broken, loose, shorted or incorrect wiring.	Refer to appropriate Wiring Diagram.

46. TIMER DOES NOT ADVANCE

POSSIBLE CAUSE	TO CORRECT
Timer is designed to pause during fill periods.	Allow completion of fill period.
Inoperative timer.	Test timer, and replace if inoperative.
Loading door is open.	Close loading door. Loading door MUST be closed any time the washer is to agitate or spin.
Washer will not fill	Timer pauses until pressure switch is satisfied. Refer to <i>paragraphs 42 and 43</i> .
Timer motor lead wire off timer terminal.	Refer to appropriate Wiring Diagram and reattach wire.
Broken, loose, or incorrect wiring.	Refer to appropriate Wiring Diagram.

47. NO AGITATION

POSSIBLE CAUSE	TO CORRECT
Inoperative timer. Timer is designed to pause (SOAK) during the DELICATE cycle.	Test timer and replace if inoperative.
Inoperative action switch.	Test switch and replace if inoperative.
Inoperative motor.	Test motor and replace if inoperative.
Inoperative pressure switch.	Test switch and replace if inoperative.
Broken, loose, or incorrect wiring.	Refer to appropriate Wiring Diagram.
Loose or broken drive belt.	Adjust or replace belt.
Inoperative transmission assembly.	Repair or replace the transmission assembly.
Sheared motor pulley roll pin.	Remove drive motor, and replace roll pin and any other damaged parts.
Drive motor overload protector has cycled.	Refer to <i>paragraph 51</i> .
Bind in pump.	Replace pump.
Loading door is open or door switch is inoperative.	Close door or test switch and replace if inoperative.

48. CONSTANT AGITATION

POSSIBLE CAUSE	TO CORRECT
Inoperative timer.	Test timer and replace if inoperative.
Inoperative drive motor.	Test motor and replace if inoperative.
Shorted or incorrect wiring.	Refer to appropriate Wiring Diagram.
Inoperative transmission assembly.	Repair or replace the transmission assembly.

49. SLOW SPIN OR NO SPIN

POSSIBLE CAUSE	TO CORRECT
Inoperative timer.	Test timer and replace if inoperative.
Some model washers, the timer is programmed for SLOW spin in the DELICATE CYCLE regardless of the action switch setting.	Use a different cycle.
Loading door is open or door safety switch is inoperative	Close loading door, or test switch and replace if inoperative.
Bind in water pump.	Replace pump.
Inoperative drive motor.	Test motor and replace if inoperative.
Loose or broken drive belt.	Adjust or replace spin belt.
Washer has gone OUT-OF-BALANCE	Open loading door to reset OUT-OF-BALANCE switch. Rearrange the load in the washtub.
No clearance or stuck brake pads.	Free sticky brake pads or replace pads.
Broken, loose, or incorrect wiring.	Refer to appropriate Wiring Diagram.
Inoperative transmission assembly.	Repair or replace the transmission assembly.

50. CONSTANT SPIN

POSSIBLE CAUSE	TO CORRECT
Inoperative timer.	Test timer and replace if inoperative.
Inoperative drive motor	Test motor and replace if inoperative.
Excessive wear on brake pads, or missing brake pads.	Replace brake pads.
Shorted or incorrect wiring.	Refer to appropriate Wiring Diagram.

51. DRIVE MOTOR OVERLOAD PROTECTOR CYCLES REPEATEDLY

POSSIBLE CAUSE	TO CORRECT
Excessive belt tension.	Adjust belts.
Inoperative motor overload protector.	Replace motor.
Bind in water pump.	Replace pump.
Bind in transmission.	Repair or replace transmission.
Brake pads binding.	Free binding pads, or replace pads.
Incorrect voltage.	Contact the local utilities company, or have a qualified electrician check the power supply.

52. OUTER TUB DOES NOT EMPTY

POSSIBLE CAUSE	TO CORRECT
Kinked drain hose.	Straighten hose.
Inoperative water pump.	Replace pump.
Obstruction in outer tub outlet hose.	Remove obstruction.
Loose or broken pump belt.	Adjust or replace belt.

53. EXCESSIVE VIBRATION

POSSIBLE CAUSE	TO CORRECT
Unbalanced load in tub.	Stop washer, redistribute load, then restart washer.
Broken, disconnected or centering spring(s) out of adjustment.	Connect or replace centering spring(s). Spring should be located in center notch, <i>Figure 63</i> .
Washer is not properly leveled.	Adjust leveling legs.
Washer in installed on weak, "spongy", or built-up floor.	Relocate washer, or support floor to eliminate weak or "spongy" condition.
Incorrect or loose cabinet screws.	Replace with correct screws or tighten.
Base damaged (washer was dropped).	Replace base assembly.
Balance ring not positioned properly on transmission assembly.	Refer to <i>paragraph 34</i> .

54. WATER LEAKING FROM OUTER TUB

POSSIBLE CAUSE	TO CORRECT
Leaking water seal in outer tub.	Replace water seal and hub assembly, <i>paragraph 27 or 28</i> .
Hole in outer tub.	Replace outer tub.
Pressure hose or accumulator leaking.	Replace pressure hose and/or accumulator.
Outer tub cover gasket leaking.	Replace gasket.
Tub-to-pump hose leaking at clamp.	Tighten clamp.

SECTION V

Test Procedures

G.E. MOTOR CHECK (Start Windings)

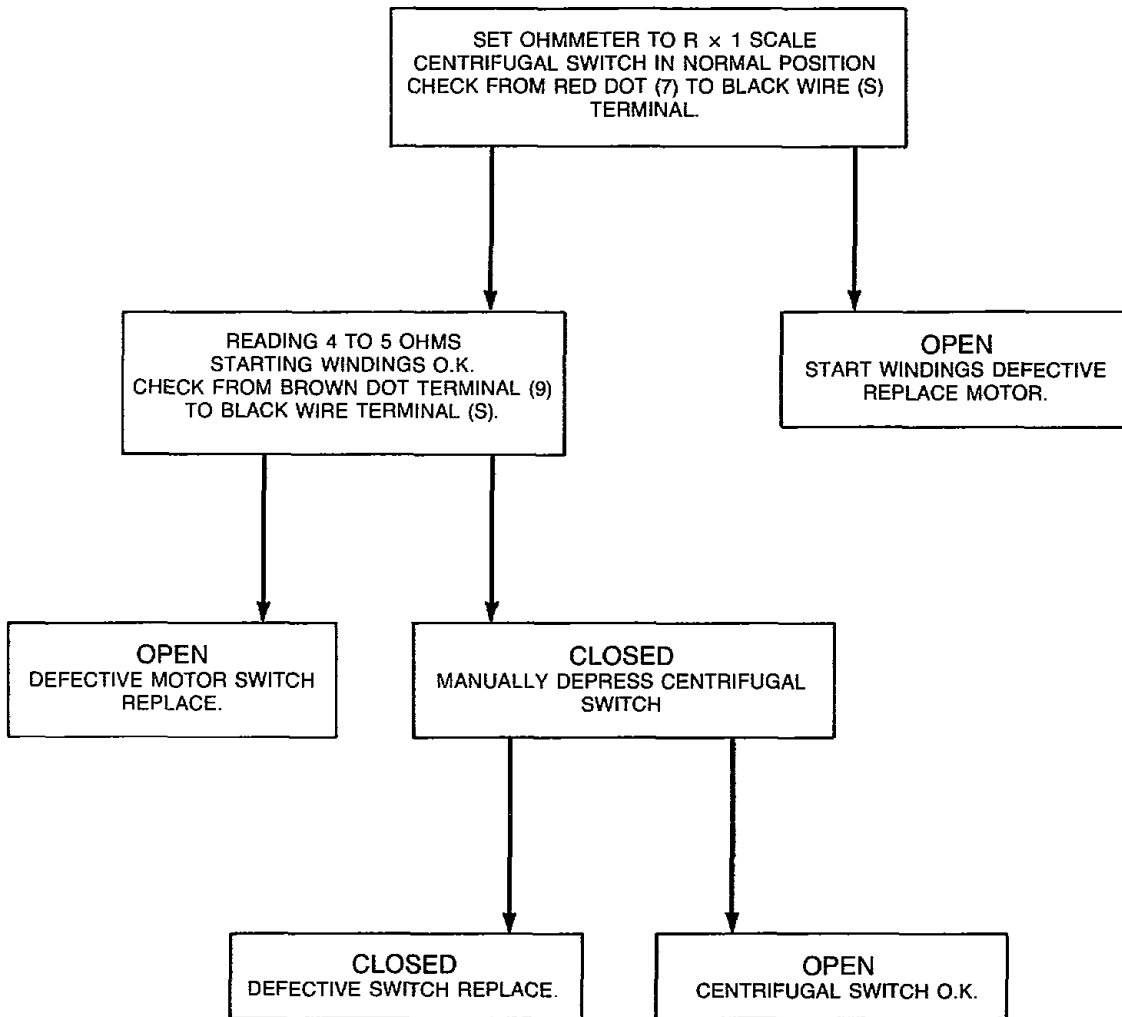

G.E. MOTOR CHECK (High and Low Windings)

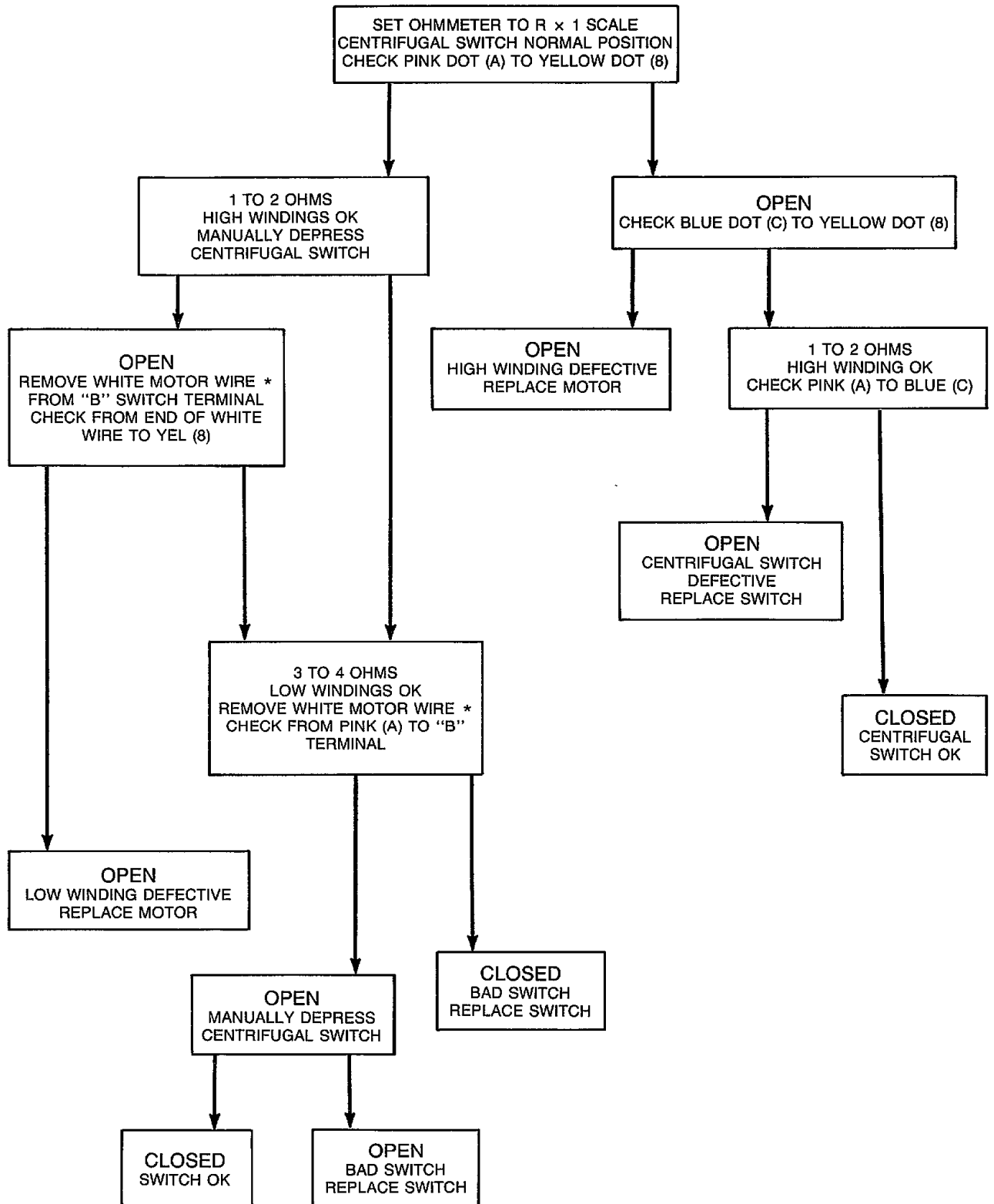

* Do not confuse white wire coming from wire harness to white dot on motor switch with the white wire coming from the motor to the "B" terminal.

SECTION VI

Cycle Sequence Charts

FUNCTION		IN USE LIGHT	RINSE LIGHT	FINAL SPIN LIGHT	WATER FILL TEMP.	CYCLE AND * MOTOR SPEED	SINGER TIME (Min. & Sec.)	MALLORY TIME (Min. & Sec.)
W A S H	Coin Slide Starting Stroke 17.82°	X			H,W,C	N = FAST PP = FAST D = SLOW	:52	:53
	AGITATE OR VARIABLE FILL	X			H,W,C	N = FAST PP = FAST D = SLOW	7:00	7:07
PAUSE		X					:21	:21
S P I N	SPIN	X				N = FAST PP = SLOW D = SLOW	1:10	1:10
	SPIN AND SPRAY	X			COLD	N = FAST PP = SLOW D = SLOW	:23	:23
	SPIN	X				N = FAST PP = SLOW D = SLOW	:14	:14
PAUSE		X					:04	:04
R I N S E	FILL (Timer Motor Runs)	X			COLD		:04	:21
	PAUSE OR FILL	X	X		COLD		:13	:13
	AGITATE OR VARIABLE FILL	X	X		COLD	N = FAST PP = FAST D = SLOW	:53	:53
PAUSE		X					:14	:16
PAUSE		X		X			:06	:03
S P I N	SPIN	X		X		N = FAST PP = FAST D = FAST	6:26	6:26
	PAUSE	X		X			:04	:08
PAUSE		X					:06	:03
OFF							:20	:21
TOTAL							18:32	18:56

KEY:

H = HOT
W = WARM
C = COLD
N = NORMAL CYCLE

PP = PERMANENT PRESS CYCLE
D = DELICATE CYCLE
X = INDICATOR LIGHT GLOW

* ON SINGLE SPEED MODEL WASHERS, ALL SPEEDS ARE FAST

**Timer No. 29241 Cycle Sequence
(Short Cycle)
(Through Serial No. 14J10537)**

FUNCTION		IN USE LIGHT	RINSE LIGHT	FINAL SPIN LIGHT	WATER FILL TEMP.	CYCLE AND * MOTOR SPEED	SINGER TIME (Min. & Sec.)	MALLORY TIME (Min. & Sec.)
W A S H	Coin Slide Starting Stroke 17.82° (Mallory) 16.84° (Singer)	X			H,W,C	N = FAST PP = FAST D = SLOW	:57	1:00
	AGITATE OR VARIABLE FILL	X			H,W,C	N = FAST PP = FAST D = SLOW	7:00	7:00
PAUSE		X					:21	:21
S P I N	SPIN	X				N = FAST PP = SLOW D = SLOW	1:25	1:25
	SPIN AND SPRAY	X			COLD	N = FAST PP = SLOW D = SLOW	:45	:45
	SPIN	X				N = FAST PP = SLOW D = SLOW	1:15	1:15
PAUSE		X					:04	:04
R I N S E	FILL (Timer Motor Runs)	X			COLD		:13	:19
	PAUSE OR FILL	X	X		COLD		:13	:13
	AGITATE OR VARIABLE FILL	X	X		COLD	N = FAST PP = FAST D = SLOW	1:01	:54
X				:09			:16	
PAUSE		X					:14	:16
PAUSE		X		X			:06	:03
S P I N	SPIN	X		X		N = FAST PP = FAST D = FAST	6:00	6:00
PAUSE		X		X			:04	:08
PAUSE		X					:06	:03
OFF							:22	:19
TOTAL							20:17	20:21

KEY:

H = HOT

W = WARM

C = COLD

N = NORMAL CYCLE

PP = PERMANENT PRESS CYCLE

D = DELICATE CYCLE

X = INDICATOR LIGHT GLOW

* ON SINGLE SPEED MODEL WASHERS, ALL SPEEDS ARE FAST

**Timer No. 3111 Cycle Sequence
(Short Cycle)
(Starting Serial No. 14J10538)**

FUNCTION		IN USE LIGHT	RINSE LIGHT	FINAL SPIN LIGHT	WATER FILL TEMP.	CYCLE AND * MOTOR SPEED	SINGER TIME (Min. & Sec.)	MALLORY TIME (Min. & Sec.)	
W A S H	Coin Slide Starting Stroke 17.82°	X			H,W,C	N = FAST PP = FAST D = SLOW	1:23	1:31	
	AGITATE OR VARIABLE FILL	X			H,W,C	N = FAST PP = FAST D = SLOW	11:12	11:17	
PAUSE		X					:34	:34	
S P I N	SPIN	X				N = FAST PP = SLOW D = SLOW	1:52	1:52	
	SPIN AND SPRAY	X			COLD	N = FAST PP = SLOW D = SLOW	:37	:37	
	SPIN	X				N = FAST PP = SLOW D = SLOW	:22	:22	
PAUSE		X					:06	:06	
R I N S E	FILL (Timer Motor Runs)	X			COLD		:06	:34	
	PAUSE OR FILL	X	X		COLD		:20	:20	
	AGITATE OR VARIABLE FILL	X	X		COLD	N = FAST PP = FAST D = SLOW	1:25	1:25	
PAUSE		X					:24	:26	
PAUSE		X		X			:10	:05	
S P I N	SPIN	X		X		N = FAST PP = FAST D = FAST	10:17	10:17	
PAUSE		X		X			:06	:13	
PAUSE		X					:13	:05	
OFF							:32	:28	
TOTAL								29:39	30:17

KEY:

H = HOT

W = WARM

C = COLD

N = NORMAL CYCLE

PP = PERMANENT PRESS CYCLE

D = DELICATE CYCLE

X = INDICATOR LIGHT GLOW

* ON SINGLE SPEED MODEL WASHERS, ALL SPEEDS ARE FAST

**Timer No. 29242 Cycle Sequence
(Long Cycle)
(Through Serial No. 14G33675)**

FUNCTION		IN USE LIGHT	RINSE LIGHT	FINAL SPIN LIGHT	WATER FILL TEMP.	CYCLE AND * MOTOR SPEED	SINGER TIME (Min. & Sec.)	MALLORY TIME (Min. & Sec.)
W A S H	Coin Slide Starting Stroke 17.82° (Mallory) 16.84° (Singer)	X			H,W,C	N = FAST PP = FAST D = SLOW	1:23	1:31
	AGITATE OR VARIABLE FILL	X			H,W,C	N = FAST PP = FAST D = SLOW	10:00	10:00
PAUSE		X					:34	:34
S P I N	SPIN	X				N = FAST PP = SLOW D = SLOW	1:25	1:25
	SPIN AND SPRAY	X			COLD	N = FAST PP = SLOW D = SLOW	:45	:45
	SPIN	X				N = FAST PP = SLOW D = SLOW	1:22	1:22
PAUSE		X					:06	:06
R I N S E	FILL (Timer Motor Runs)	X			COLD		:06	:34
	PAUSE OR FILL	X	X		COLD		:20	:20
	AGITATE OR VARIABLE FILL	X X	X		COLD	N = FAST PP = FAST D = SLOW	3:19 :24	3:20 :23
PAUSE		X					:24	:25
		X		X			:10	:11
S P I N	SPIN	X		X		N = FAST PP = FAST D = FAST	8:30	8:30
PAUSE		X		X			:06	:18
		X					:13	:05
OFF							:32	:28
TOTAL							29:39	30:17

KEY:

H = HOT

W = WARM

C = COLD

N = NORMAL CYCLE

PP = PERMANENT PRESS CYCLE

D = DELICATE CYCLE

X = INDICATOR LIGHT GLOW

* ON SINGLE SPEED MODEL WASHERS, ALL SPEEDS ARE FAST

**Timer No. 31682 Cycle Sequence
(Long Cycle)
(Starting Serial No. 14G33676)**

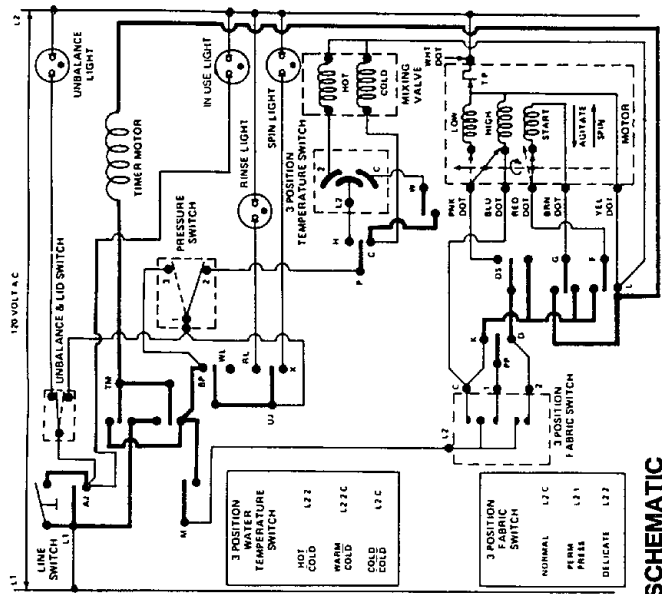

WARNING
 FAILURE TO INSTALL, MAINTAIN AND/OR OPERATE THIS MACHINE'S INSTRUCTIONS MAY RESULT IN CONDITIONS WHICH CAN PRODUCE BODILY INJURY AND/OR PROPERTY DAMAGE

THIS MACHINE MANUFACTURER UNDERTAKES NONE OF THE FOLLOWING PATENTS

UNITED STATES NO. 3,253,874 3,638,755 3,845,642 3,590,664

CANADIAN NO. 1,008,265 964,885

OTHER PATENTS PENDING

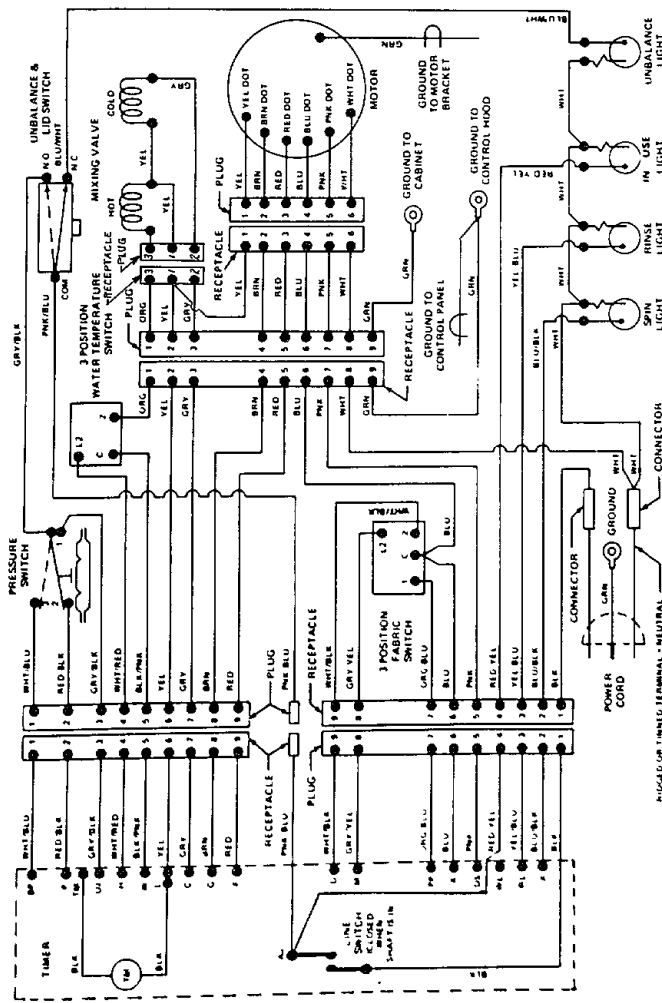

USER SELLS 28 MINUTLS 45 SECONDS PLUS VARIABLE FILL TIME

LINE SWITCH CARRIED OPEN

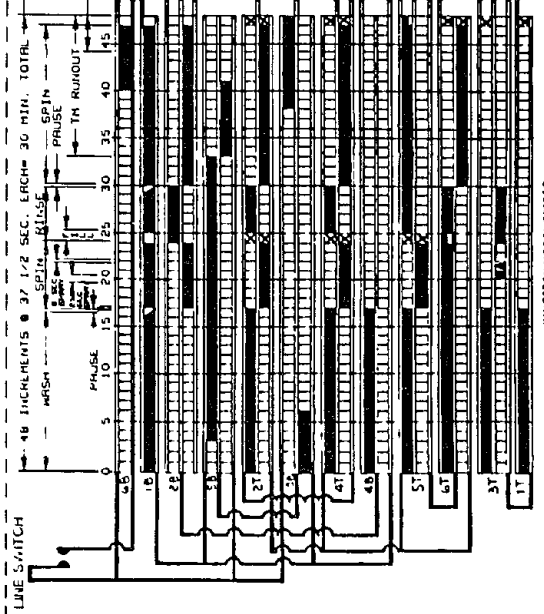

CONTACTS CLOSED CURRENT FLOW

CONTACTS MAY BE OPEN OR CLOSED

CONTACTS CLOSED NO CURRENT FLOW

KINGSTON MODEL 7748EG

Models WA4720 and WA4721

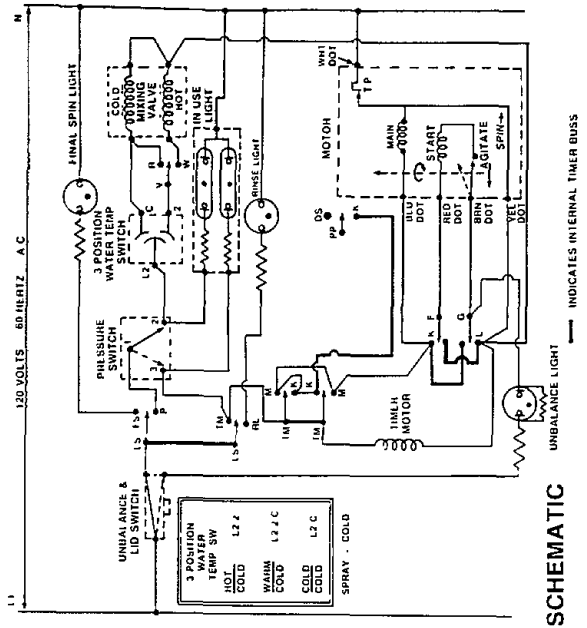

SCHEMATIC

INDICATES INTERNAL TIMER BUSS

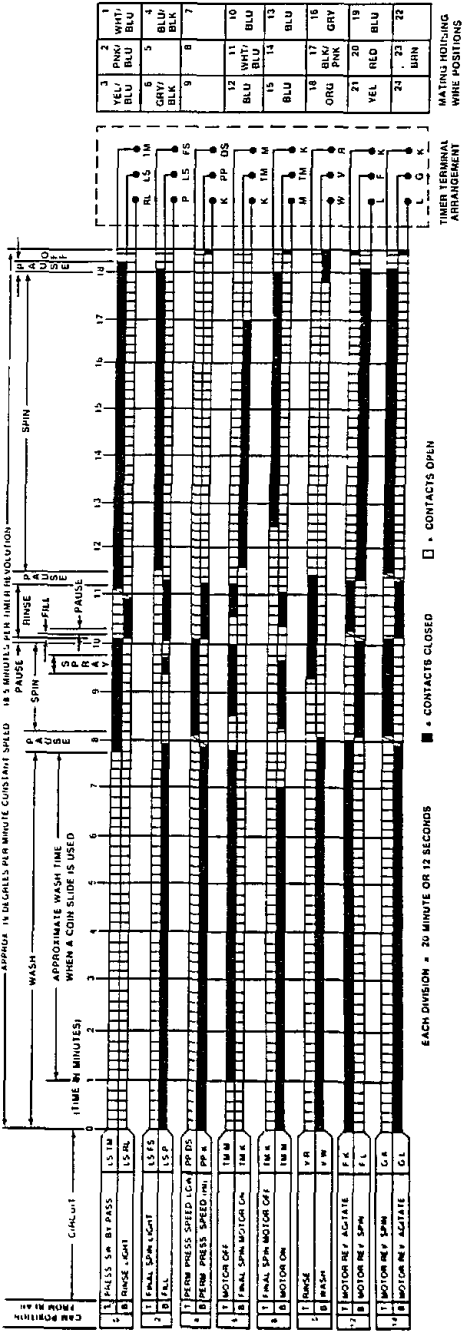
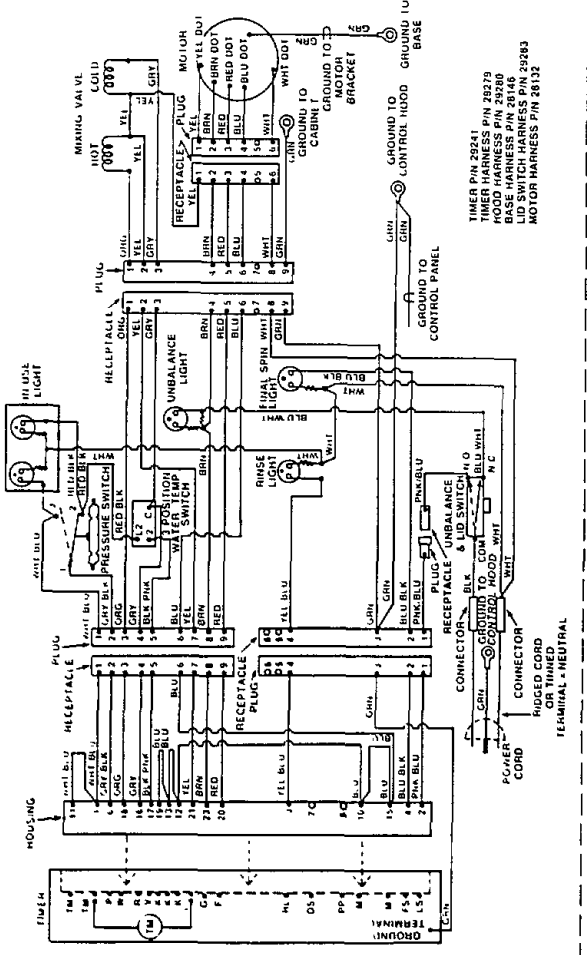

WARNING
FAILURE TO INSTALL, MAINTAIN AND/OR OPERATE THIS MACHINE ACCORDING TO MANUFACTURER'S INSTRUCTIONS MAY RESULT IN PERSONAL INJURY AND/OR PROPERTY DAMAGE

THIS MACHINE MANUFACTURED BY THE MANUFACTURER OF THE FOLLOWING PATENTS
UNITED STATES NO. 3,233,874
OTHER PATENTS PENDING

Models WA4950 and WA4951 (Starting Serial No. 14N82612)

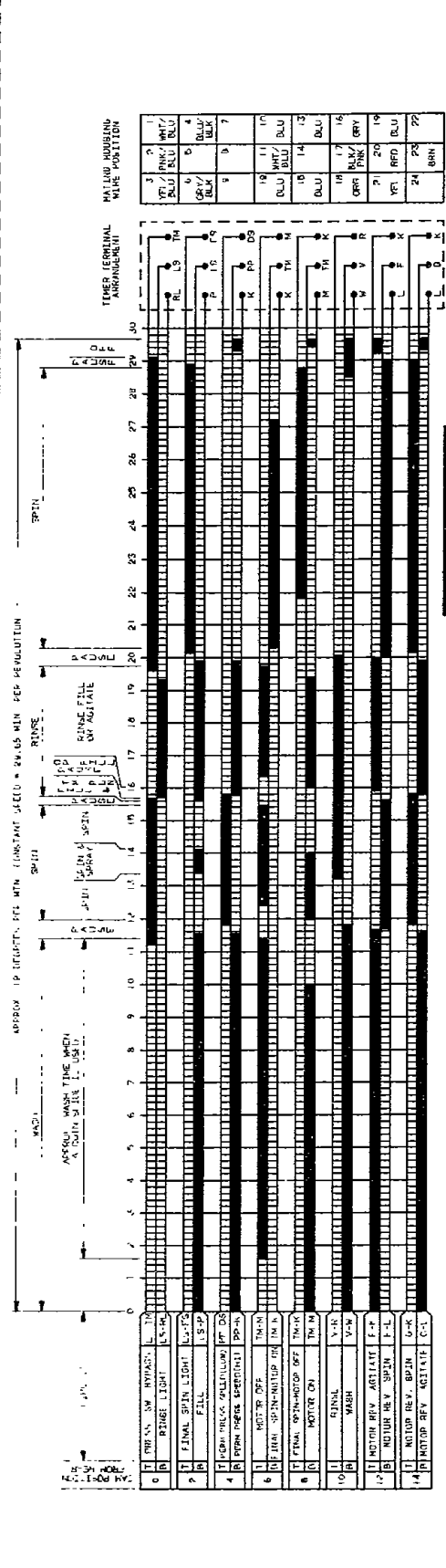
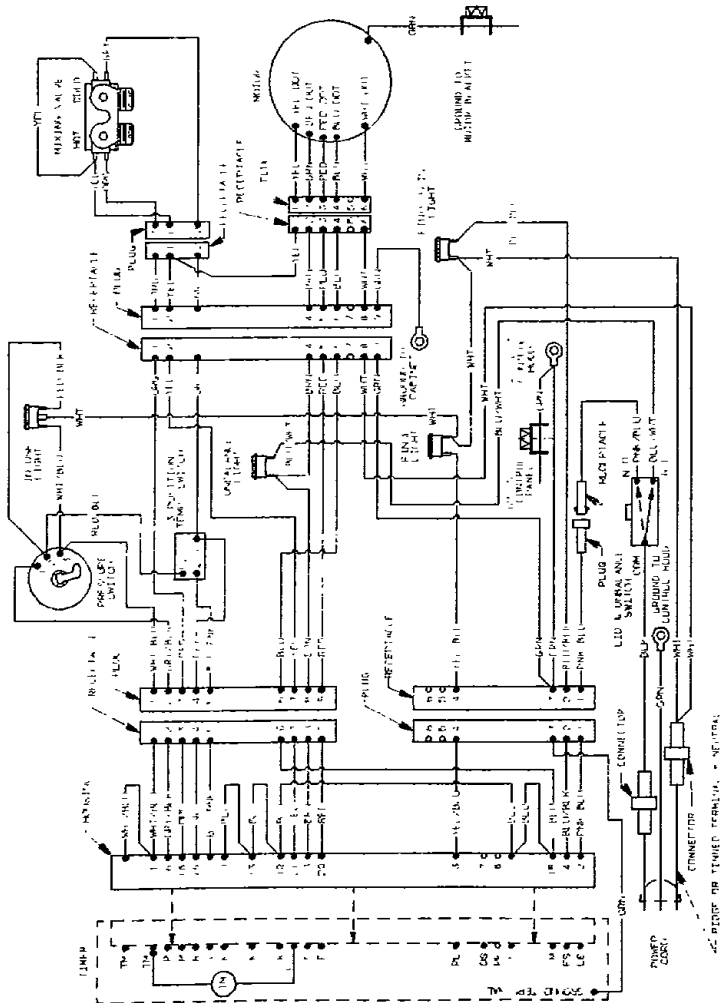
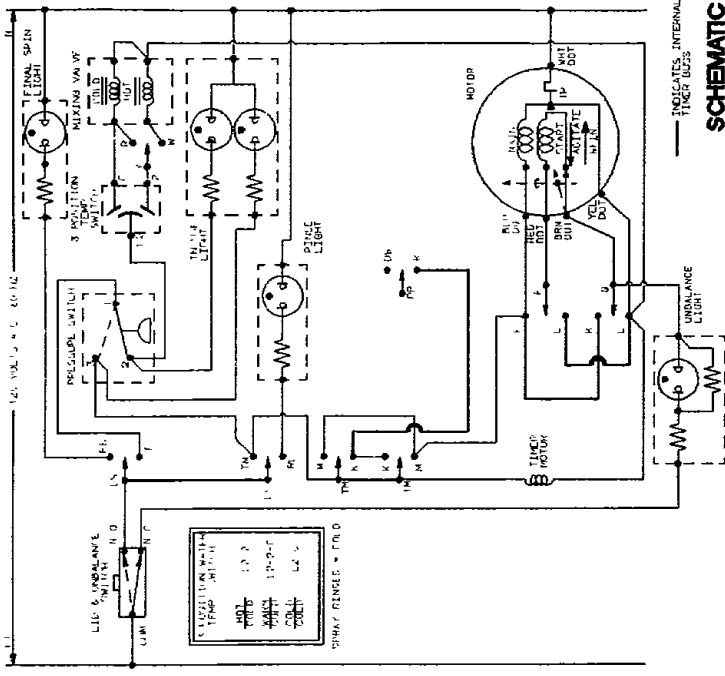

WARNING

READ INSTRUCTIONS
BEFORE OPERATING
AND/OR REPAIRING THIS MACHINE.
FAILURE TO FOLLOW THESE INSTRUCTIONS
MAY CAUSE PERSONAL INJURY OR
PROPERTY DAMAGE.

THIS MACHINE MANUFACTURED
UNDER ONE OR MORE OF THE
FOLLOWING PATENTS:
UNITED STATES NO. 3,063,874;
CANADA NO. 1,008,644;
MEXICO NO. 1,008,266;
OTHER PATENTS PENDING.

Models WA4960 and WA4961 (Through Serial No. 14N82611)

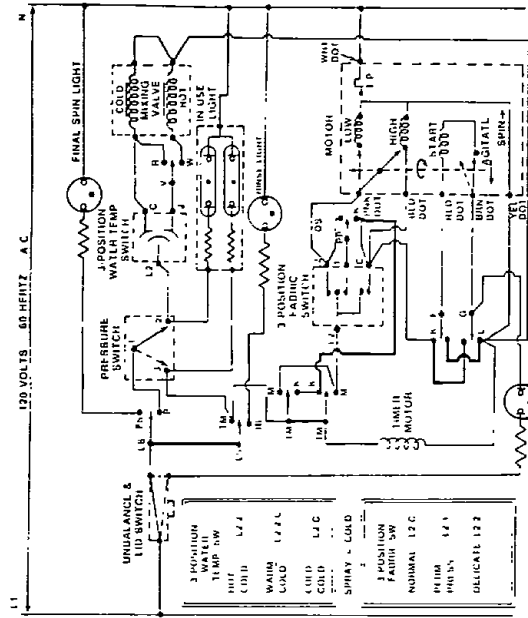

SCHEMATIC

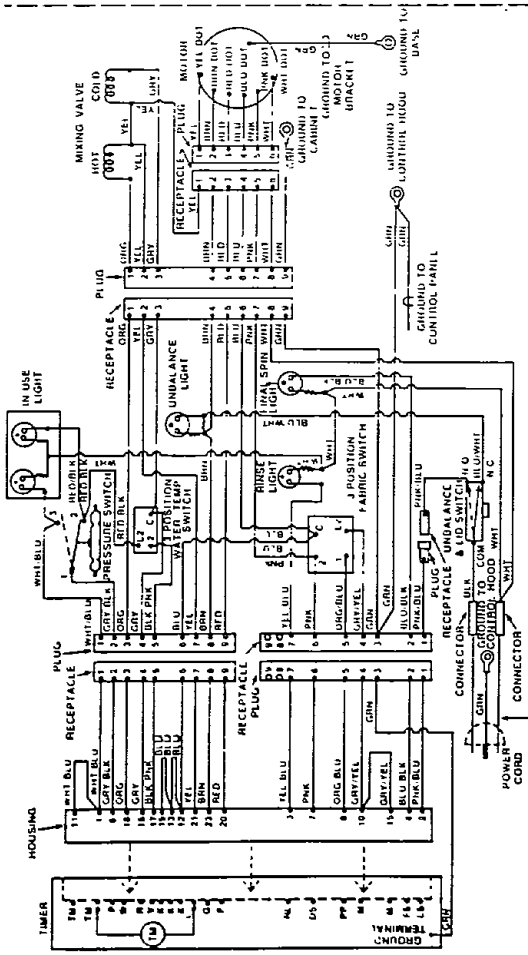

TERMINAL ARRANGEMENT

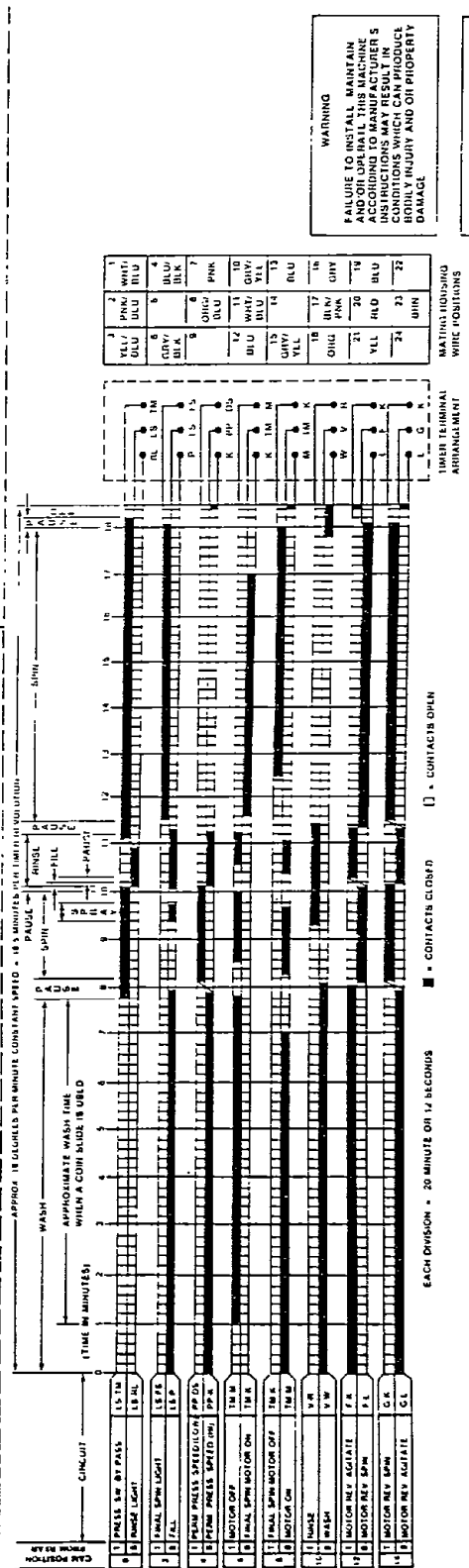

TIMER CHART

WARNING
FAILURE TO INSTALL MAINTAIN AND OPERATE THIS MACHINE ACCORDING TO MANUFACTURER'S INSTRUCTIONS MAY RESULT IN CONDITIONS WHICH CAN PRODUCE PERSONAL INJURY AND OR PROPERTY DAMAGE.

THIS MACHINE MANUFACTURED UNDER ONE OR MORE OF THE FOLLOWING PATENTS
UNITED STATES NO. 3,253,874
OTHER PATENTS PENDING

Models WA4970 and WA4971 (Through Serial No. 14N82611)

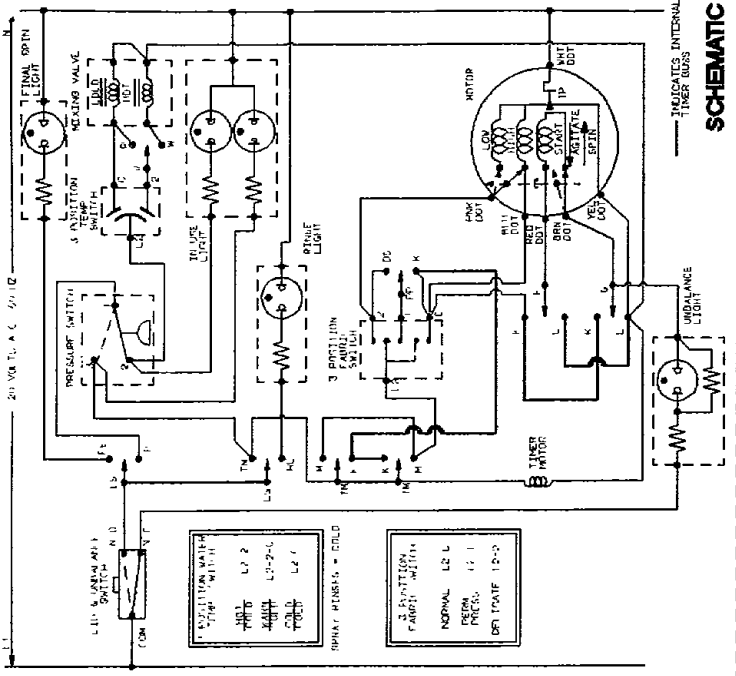

SCHEMATIC

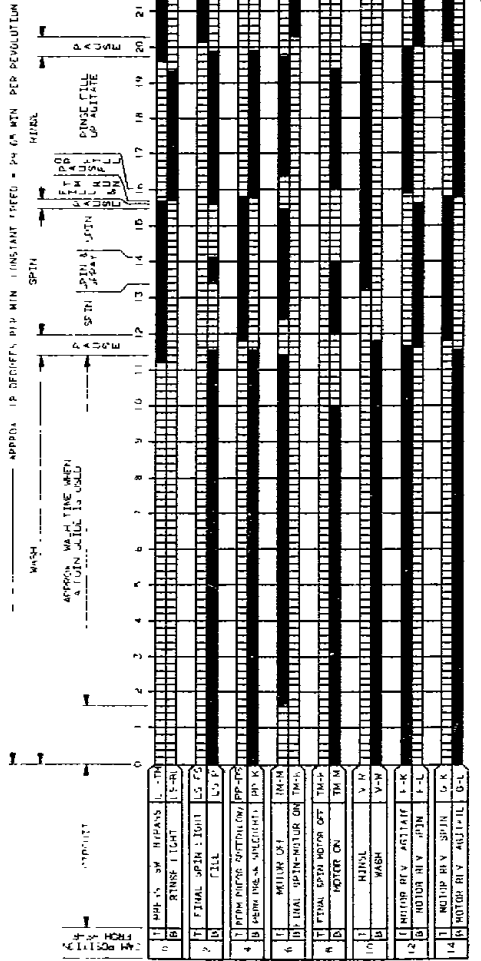
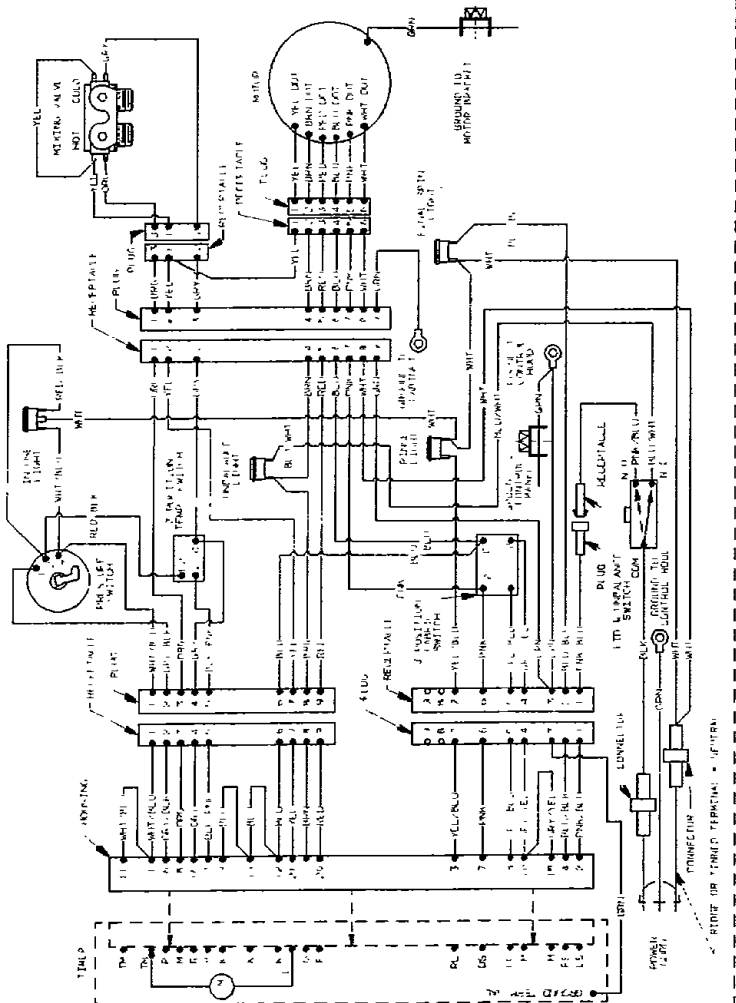

THIS MACHINE, MANUFACTURED UNDER ONE OR MORE OF THE FOLLOWING PATENTS, UNITED STATES NO. 3,253,874; 3,838,785; 3,842,642; CANADIAN NO. 1,009,269; 994,609. OTHER PATENTS PENDING.

WARNING
 DO NOT OPERATE THIS MACHINE ACCORDING TO MANUFACTURER'S INSTRUCTIONS WHICH CAN PRODUCE SERIOUS INJURY OR DEATH.

**Models WA4980 and WA4981
 (Through Serial No. 14N82611)**

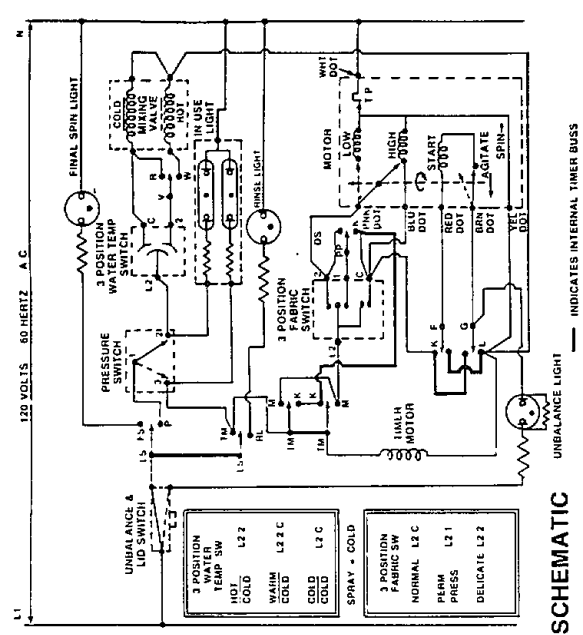

SCHEMATIC — INDICATES INTERNAL TIMER BUSS

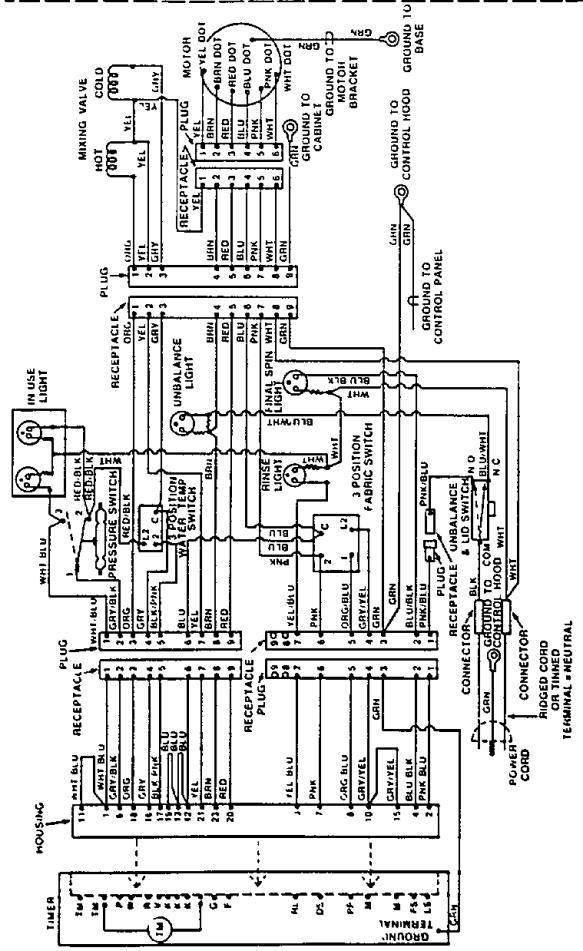

APPROX 12 DEGREES PER MINUTE CONSTANT SPEED • 28.5 MINUTES PER TIMER REVOLUTION

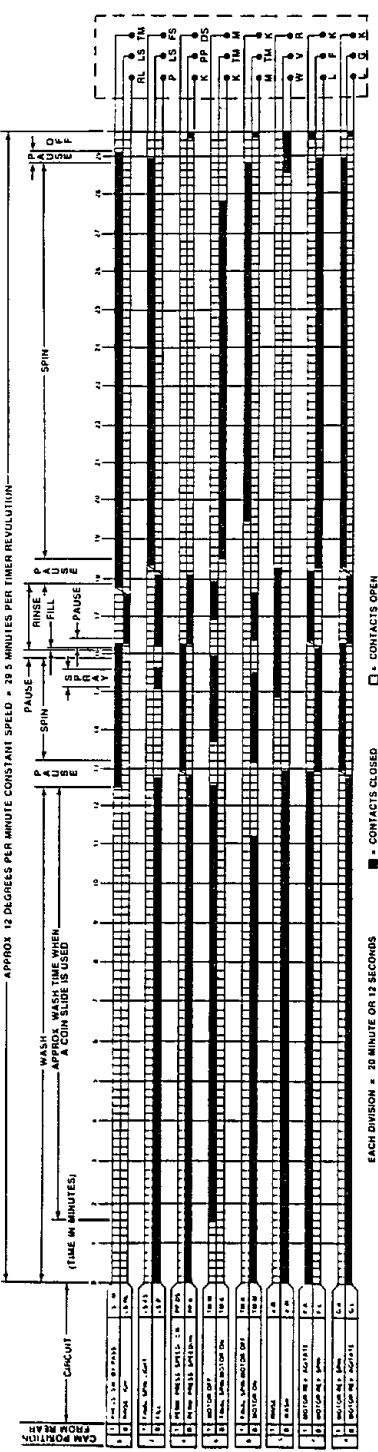

WARNING
FAILURE TO INSTALL, MAINTAIN OR OPERATE THIS MACHINE ACCORDING TO MANUFACTURER'S INSTRUCTIONS MAY RESULT IN PERSONAL INJURY AND/OR PROPERTY DAMAGE

WARNING
THIS MACHINE MANUFACTURED UNDER ONE OR MORE OF THE FOLLOWING PATENTS UNITED STATES NO. 3 253 874 OTHER PATENTS PENDING

Models WA4980 and WA4981 (Starting Serial No. 14N82612)